

MCKELVEY

ENTERPRISES

MCKELVEYENTERPRISES.COM

Product Catalog



Table of Contents

| | |
|--------------------------------------------|------------------|
| Axle Components _____ | Section A |
| Suspensions & Components _____ | Section B |
| Hubs & Components _____ | Section C |
| Brakes & Components _____ | Section D |
| Tires & Wheels _____ | Section E |
| Fender & Body _____ | Section F |
| Couplers & Jacks _____ | Section G |
| Brake Control & Actuators _____ | Section H |
| Lights & Connectors _____ | Section I |
| Hardware Accessories _____ | Section J |
| Towing Accessories _____ | Section K |
| Dump Hoist and Accessories _____ | Section L |

Section A

Axles and Components

| | |
|--------------------------------------|--------------|
| Axle Ordering and Measurements | A-1 thru A-3 |
| 2K Axles | A-4 |
| 3.5K Axles | A-5 |
| 5.2K Axles | A-6 |
| 7K Axles | A-7 |
| 8K Axles | A-8 |
| 10K Axles | A-9 |
| 12K & 15K Axles | A-10 |
| 22.5K thru 27.5K Axles | A-11 |
| Spindle Options | A-11 |

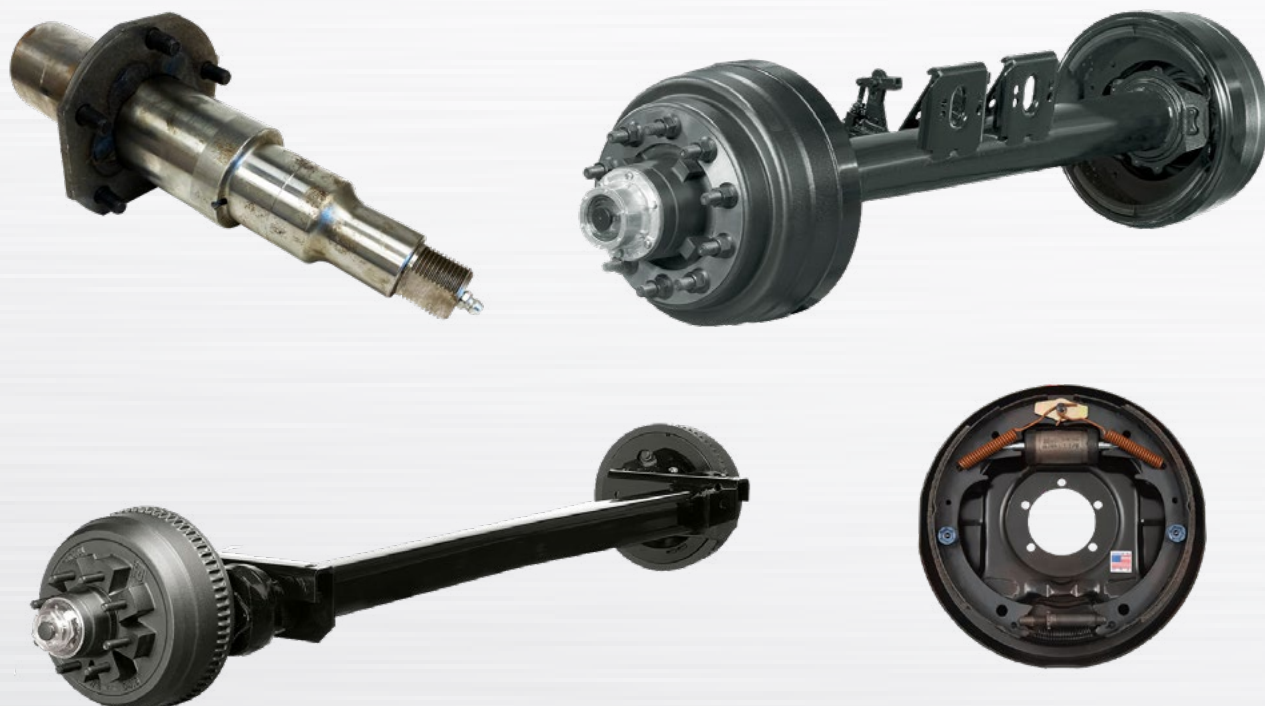

AXLE ORDERING AND MEASUREMENTS

Accurate measurement of your axle is important to ensure you get exactly what is needed to get the job done right. The following information is intended to assist you in selecting the correct axle for your particular needs. If you have questions or need further assistance, we have a team of experienced sales associates to point you in the right direction and assist with any questions you may have.

McKelvey Enterprises offers 3 types of axles from Dexter:

- **Straight** - Straight square or round bar
- **Drop** - Offset spindles drop slightly lower than straight bar
- **Torsion (Torflex®)** - Torsion arm type suspension that is completely contained in the axle tube

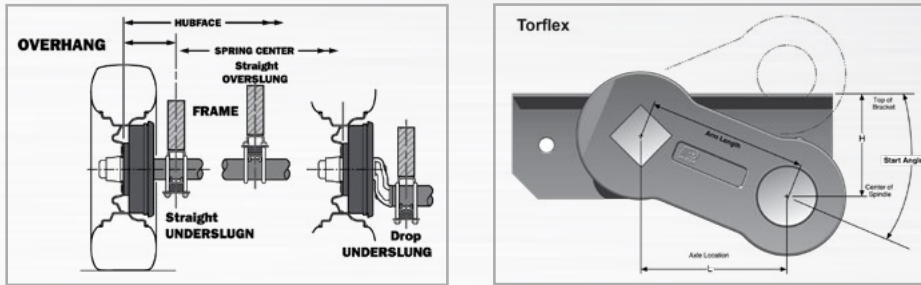

How to measure your Axle

There are several methods that can be used to measure an axle accurately. McKelvey Enterprises recommends that axles be measured using the following methods:

Hub Face to Hub Face (Track) Measurement - This is done by measuring from the front of one hub to the front of the opposite hub. Do not measure from the back of the hub because your measurement will be incorrect.

Spring Center to Spring Center Measurement - Measure from one spring center to the other spring center. Correct measurement is crucial for installation.

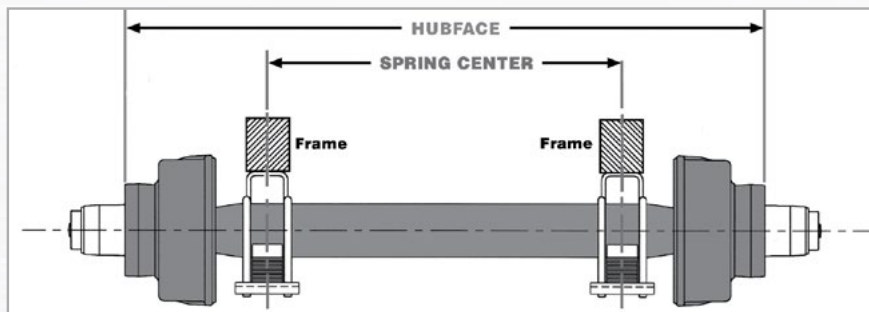

Flange to Flange Measurement - This method should be used if the hubs are not on the axle. This is measured from the outer surface of the flange to the same location on the opposite side of the axle.



Equation Chart for Flange to Flange Measurements

| Axle Model | Equation |
|-------------------|---------------------------------------|
| 2K | Hub Face = Outside of flanges + 6.90 |
| 3.5K | Hub Face = Outside of flanges + 6.34 |
| 5.2K - 7K | Hub Face = Outside of flanges + 8.73 |
| 7.2K | Hub Face = Outside of flanges + 7.54 |
| 8K | Hub Face = Outside of flanges + 9.09 |
| 9K, 10K Gen. Duty | Hub Face = Outside of flanges + 13.50 |
| 10K Heavy Duty | Hub Face = Outside of flanges + 14.35 |
| 12K High Profile | Hub Face = Outside of flanges + 15.27 |
| 15K | Hub Face = Outside of flanges + 17.45 |

AXLE ORDERING AND MEASUREMENTS

Bolt Pattern Measurement

Determining the bolt pattern on your trailer:

Trailer wheel bolt patterns are defined by the number of bolts (lugs) per wheel and the diameter of the circle that the bolts are arranged on. For instance, a 5 - 5.50" bolt pattern is a hub with 5 bolts (lugs) evenly spaced on a 5.50" diameter circle.

If your trailer wheel has an **even** number of bolts (lugs), measure from the center of one bolt to the center of the bolt directly across with a tape measure.

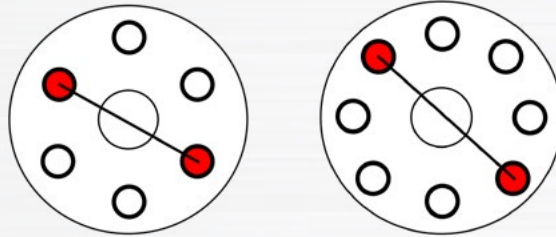

If your trailer wheel has 5 bolts (lugs), measure from the back edge of one bolt to the center of the of the bolt directly across. Always skip one bolt between when measuring.

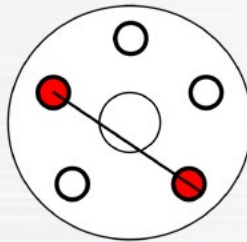

Spindle Options

Sprung axles are available with straight or drop spindles.

Torsion (Torflex®) axles use angles on a torsion arm.

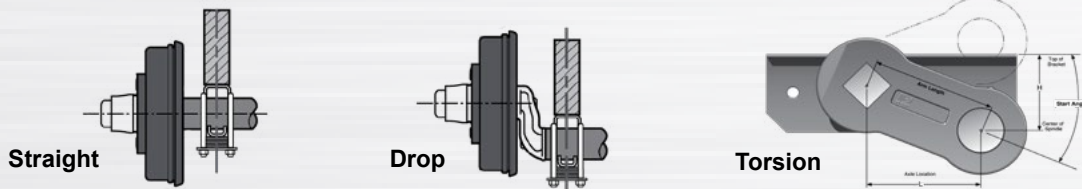

Brake Options



Electric



Drum



Disc

AXLE ORDERING AND MEASUREMENTS

Axle Part Numbers

Sprung Axles

Example Part #: **550188**

550 = Bolt Pattern **1** = Brake Type **88** = Track Dimension (add 1" for hub face)

| Bolt Patterns | |
|---------------|-----------|
| Number | Type |
| 440 | 4 - 4.00" |
| 545 | 5 - 4.50" |
| 5475 | 5 - 4.75" |
| 550 | 5 - 5.00" |
| 555 | 5 - 5.50" |
| 655 | 6 - 5.50" |
| 660 | 6 - 6.00" |
| 865 | 8 - 6.50" |
| 880 | 8 - 8.00" |

| Brake Type Options | |
|--------------------|----------------|
| Number | Type |
| 1 | Idler |
| 2 | Electric |
| 3 | Hydraulic Drum |
| 4 | Hydraulic Disc |
| 5 | Air |



Torflex Axles

Example Part #: **12294**

12 = #12 Capacity **2** = Brake Type **94** = Track Dimension (add 1" for hub face)

| Capacity | |
|----------|----------------|
| Number | Capacity (lbs) |
| #9 | 2200 |
| #10 | 3500 |
| #11 | 6000 |
| #12 | 7000 |
| #13 | 8000 |
| T100 | 10000 |
| T1200 | 12000 |

| Brake Type Options | |
|--------------------|----------------|
| Number | Type |
| 1 | Idler |
| 2 | Electric |
| 3 | Hydraulic Drum |
| 4 | Hydraulic Disc |



2000 LBS CAPACITY

| Bolt Pattern | Straight Axle Tube | Drop Axle Tube | Hydraulic Brake | Electric Brake | Stud | Spindle |
|--------------|--------------------|----------------|-----------------|----------------|------|---------|
| 4 - 4.00" | 1 3/4" | 2 3/8" | N/A | N/A | 1/2" | 1-1/16" |
| 5 - 4.50" | 1 3/4" | 2 3/8" | 7" x 1 1/4" | 7" x 1 1/4" | 1/2" | 1-1/16" |

Torflex® Application Information

Full Load Dimensions

Dimensions are for low profile, top mount only. High profile brackets are .88" higher. Side mount is .18" higher.
Allow 3" bump clearance from full load.

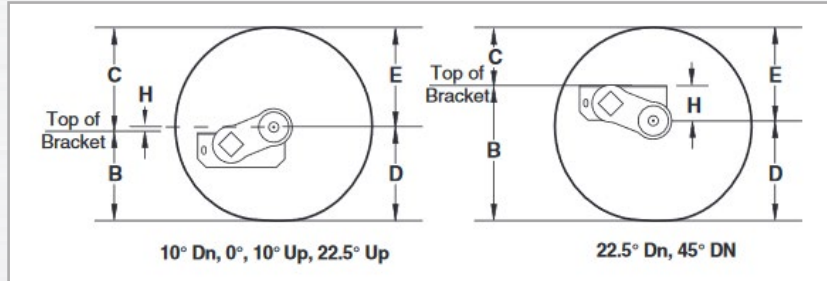

Start Angle

| Tire | 45° Down | | | | | 32° Down | | | | | 22.5° Down | | |
|-----------------|----------|------|-----|------|-----|----------|------|-----|------|-----|------------|------|------|
| | D | E | H | B | C | D | E | H | B | C | H | B | C |
| ST175/80R13 | 11.2 | 12.0 | 3.5 | 14.7 | 8.5 | 11.2 | 12.0 | 2.2 | 13.4 | 9.8 | 1.2 | 12.4 | 10.8 |
| 4.80 - 8 | 7.9 | 8.8 | 3.5 | 11.4 | 5.3 | 7.9 | 8.8 | 2.2 | 10.1 | 6.6 | 1.2 | 9.1 | 7.6 |
| 4.80 - 12 | 9.5 | 10.8 | 3.5 | 13.0 | 7.3 | 9.5 | 10.8 | 2.2 | 11.7 | 8.6 | 1.2 | 10.7 | 9.6 |
| 20.5 x 8.0 - 10 | 9.7 | 10.8 | 3.5 | 13.2 | 7.3 | 9.7 | 10.8 | 2.2 | 11.9 | 8.6 | 1.2 | 10.9 | 9.6 |

Columns D and E are dimensional examples only. D - Static Loaded Radius E - Inflated Radius

| Tire | 10° Down | | | 0° | | | 10° Up | | | 22.5° Up | | |
|-----------------|----------|------|------|------|------|------|--------|-----|------|----------|-----|------|
| | H | B | C | H | B | C | H | B | C | H | B | C |
| ST175/80R13 | -0.1 | 11.1 | 12.1 | -1.1 | 10.1 | 13.1 | -2.0 | 9.2 | 14.0 | -3.0 | 8.2 | 15.0 |
| 4.80 - 8 | -0.1 | 7.8 | 8.9 | -1.1 | 6.8 | 9.9 | -2.0 | 5.9 | 10.8 | -3.0 | 4.9 | 11.8 |
| 4.80 - 12 | -0.1 | 9.4 | 10.9 | -1.1 | 8.4 | 11.9 | -2.0 | 7.5 | 12.8 | -3.0 | 6.5 | 13.8 |
| 20.5 x 8.0 - 10 | -0.1 | 9.6 | 10.9 | -1.1 | 8.6 | 11.9 | -2.0 | 7.7 | 12.8 | -3.0 | 6.7 | 13.8 |

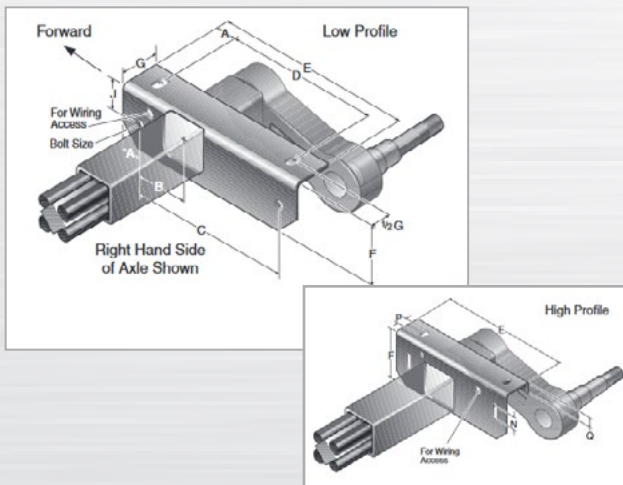

#9 Bracket Dimensions

| | Low | High |
|-----------|-----------|-------|
| A | 1.00 | 1.00 |
| B | 2.38 | 2.38 |
| C | 8.00 | 8.00 |
| D | 7.75 | 7.75 |
| E | 10.00 | 10.00 |
| F | 2.88 | 3.75 |
| G | 2.00 | 2.00 |
| J | 1.57 | 1.57 |
| N | --- | .86 |
| P | .94 | .94 |
| Q | 1.00 | 1.00 |
| Bolt Size | 1/2" bolt | |
| Tube Size | 2.17 | 2.17 |

#9 Overhang Per Side

| Spindle | Min. | Max. |
|----------|-------|--------|
| Short | 6.00" | 10.90" |
| Standard | 6.50" | 10.90" |

3500 LBS CAPACITY

| Bolt Pattern | Axle Tube | Drop | Brake | Stud | Spindle |
|--------------|-----------|----------|-------------|------|---------|
| 5 - 4.50" | 2 3/8" | 4" or 6" | 10 x 2-1/4" | 1/2" | #84 |
| 5 - 4.75" | 2 3/8" | 4" or 6" | 10 x 2-1/4" | 1/2" | #84 |
| 5 - 5.00" | 2 3/8" | 4" or 6" | 10 x 2-1/4" | 1/2" | #84 |
| 5 - 5.50" | 2 3/8" | 4" or 6" | 10 x 2-1/4" | 1/2" | #84 |
| 6 - 5.50" | 2 3/8" | 4" or 6" | 10 x 2-1/4" | 1/2" | #84 |

Torflex® Application Information

Full Load Dimensions

Dimensions are for low profile, top mount only. High profile brackets are .82" higher. Side mount is .18" higher.
Allow 3" bump clearance from full load.

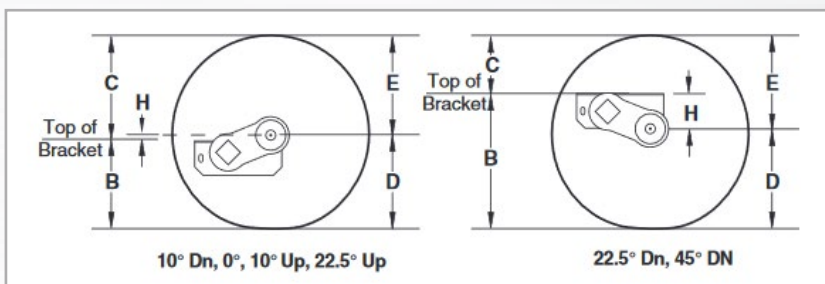

Start Angle

| Tire | 45° Down | | | | | 32° Down | | | | | 22.5° Down | | |
|-------------|----------|------|-----|------|------|----------|------|-----|------|------|------------|------|------|
| | D | E | H | B | C | D | E | H | B | C | H | B | C |
| ST175/80R13 | 11.2 | 12.0 | 3.8 | 15.0 | 8.2 | 11.2 | 12.0 | 2.5 | 13.4 | 9.5 | 1.5 | 12.7 | 10.5 |
| ST205/75R14 | 12.1 | 13.1 | 3.8 | 15.9 | 9.3 | 12.1 | 13.1 | 2.5 | 14.6 | 10.6 | 1.5 | 13.6 | 11.6 |
| ST225/75R15 | 13.0 | 14.4 | 3.8 | 16.8 | 10.6 | 13.0 | 14.4 | 2.5 | 15.5 | 11.9 | 1.5 | 14.5 | 12.9 |

Columns D and E are dimensional examples only. D - Static Loaded Radius E - Inflated Radius

| Tire | 10° Down | | | 0° | | | 10° Up | | | 22.5° Up | | |
|-------------|----------|------|------|------|------|------|--------|------|------|----------|------|------|
| | H | B | C | H | B | C | H | B | C | H | B | C |
| ST175/80R13 | 0.2 | 11.4 | 11.8 | -0.8 | 10.4 | 12.8 | -1.7 | 9.5 | 13.7 | -2.8 | 8.4 | 14.8 |
| ST205/75R14 | 0.2 | 12.3 | 12.9 | -0.8 | 11.3 | 13.9 | -1.7 | 10.4 | 14.8 | -2.8 | 9.3 | 15.9 |
| ST225/75R15 | 0.2 | 13.2 | 14.2 | -0.8 | 12.2 | 15.2 | -1.7 | 11.3 | 16.1 | -2.8 | 10.2 | 17.2 |

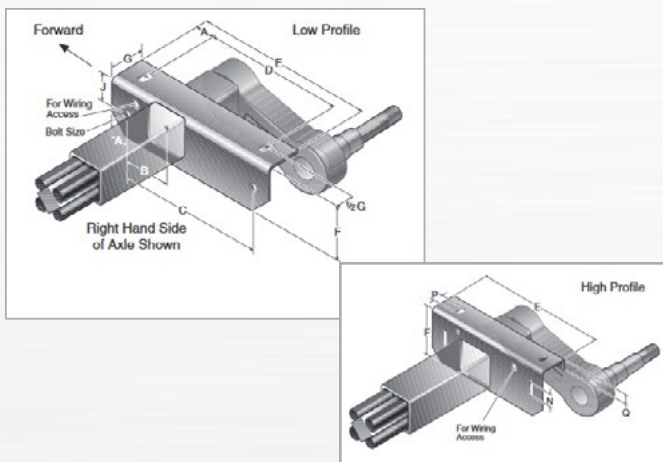

#10 Bracket Dimensions

| | Low | High |
|-----------|-----------|-------|
| A | 1.00 | 1.00 |
| B | 2.50 | 2.50 |
| C | 8.00 | 8.00 |
| D | 8.00 | 8.00 |
| E | 10.00 | 10.00 |
| F | 3.43 | 4.25 |
| G | 2.50 | 2.50 |
| J | 1.62 | 1.62 |
| N | --- | 1.03 |
| P | --- | 1.00 |
| Q | --- | 1.00 |
| Bolt Size | 5/8" bolt | |
| Tube Size | 2.62 | 2.62 |

Overhang Per Side

| Spindle | Min. | Max. | Max. Capacity |
|---------------------|-------|--------|---------------|
| #10 Standard w/Drum | 6.30" | 11.80" | 3500 |
| #10 w/Disc Brake | 6.56" | 11.80" | 3500 |
| #10F w/Drum | 6.30" | 10.50" | 4000 |
| #10L w/Drum | 5.88" | 13.76" | 3000 |

5200 LBS CAPACITY

| Bolt Pattern | Axle Tube | Drop | Brake | Stud | Spindle |
|--------------|-----------|------|---------|------|---------|
| 6 - 5.50" | 3" | 4" | 12 x 2" | 1/2" | #42 |
| 6 - 6.00" | 3" | 4" | 12 x 2" | 1/2" | #42 |

Torflex® Application Information

Full Load Dimensions

Dimensions are for low profile, top mount only. High profile brackets are .75" higher. Side mount is .25" higher. Allow 3" bump clearance from full load.

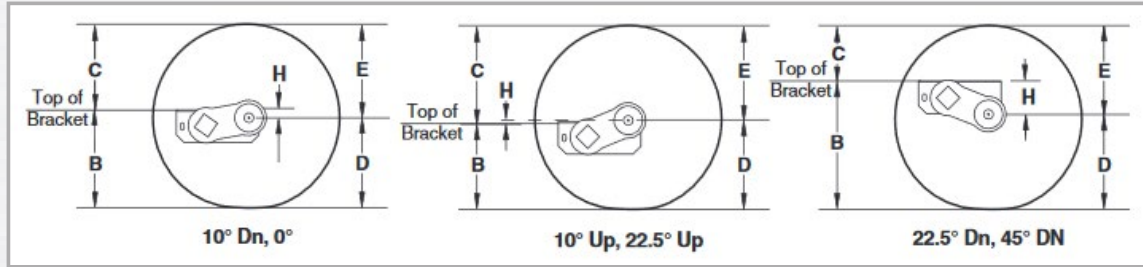

Start Angle

| Tire | 45° Down | | | | | 32° Down | | | | | 22.5° Down | | |
|-------------|----------|------|-----|------|------|----------|------|-----|------|------|------------|------|------|
| | D | E | H | B | C | D | E | H | B | C | H | B | C |
| ST225/75R15 | 13.0 | 14.4 | 4.1 | 17.1 | 10.3 | 13.0 | 14.4 | 2.8 | 15.8 | 11.6 | 1.8 | 14.8 | 12.6 |
| LT235/85R16 | 14.3 | 15.4 | 4.1 | 18.4 | 11.3 | 14.3 | 15.4 | 2.8 | 17.1 | 12.6 | 1.8 | 16.1 | 13.6 |
| LT225/75R16 | 13.5 | 14.9 | 4.1 | 17.6 | 10.8 | 13.5 | 14.9 | 2.8 | 16.3 | 12.1 | 1.8 | 15.3 | 13.1 |
| 8.75R16.5LT | 13.8 | 14.8 | 4.1 | 17.9 | 10.7 | 13.8 | 14.8 | 2.8 | 16.6 | 12.0 | 1.8 | 15.6 | 13.0 |

Columns D and E are dimensional examples only. D - Static Loaded Radius E - Inflated Radius

| Tire | 10° Down | | | 0° | | | 10° Up | | | 22.5° Up | | |
|-------------|----------|------|------|------|------|------|--------|------|------|----------|------|------|
| | H | B | C | H | B | C | H | B | C | H | B | C |
| ST225/75R15 | 0.5 | 13.5 | 13.9 | -0.5 | 12.5 | 14.9 | -1.5 | 11.5 | 15.9 | -2.5 | 10.5 | 16.9 |
| LT235/85R16 | 0.5 | 14.8 | 14.9 | -0.5 | 13.8 | 15.9 | -1.5 | 12.8 | 16.9 | -2.5 | 11.8 | 17.9 |
| LT225/75R16 | 0.5 | 14.0 | 14.4 | -0.5 | 13.0 | 15.4 | -1.5 | 12.0 | 16.4 | -2.5 | 11.0 | 17.4 |
| 8.75R16.5LT | 0.5 | 14.3 | 14.3 | -0.5 | 13.3 | 15.3 | -1.5 | 12.3 | 16.3 | -2.5 | 11.3 | 17.3 |

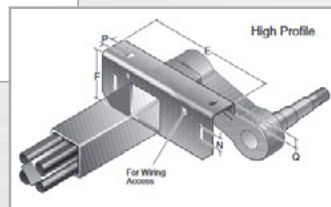
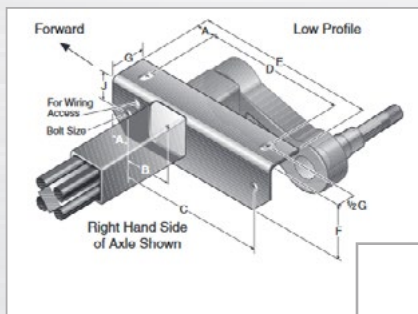

#11 Bracket Dimensions

| | Low | High |
|-----------|-----------|-------|
| A | .75 | .75 |
| B | 3.50 | 3.50 |
| C | 9.50 | 9.50 |
| D | 9.00 | 9.00 |
| E | 11.00 | 11.00 |
| F | 3.91 | 4.66 |
| G | 2.50 | 2.50 |
| J | 1.83 | 1.83 |
| N | --- | 1.03 |
| P | --- | 1.00 |
| Q | --- | 1.00 |
| Bolt Size | 5/8" bolt | |
| Tube Size | 3.03 | 3.03 |

#11 Overhang Overall

| Spindle | Min. | Max. |
|-----------------|--------|--------|
| Short | 14.00" | 20.44" |
| Short - Disc | 14.25" | 20.50" |
| Standard | 15.00" | 20.44" |
| Standard - Disc | 15.00" | 20.50" |

AXLES AND COMPONENTS

7000 LBS CAPACITY

| Bolt Pattern | Axle Tube | Drop | Brake | Stud | Spindle |
|--------------|-----------|------|---------|-------------------|---------|
| 8 - 6.50" | 3" | 4" | 12 x 2" | 1/2", 3/16", 5/8" | #42 |

Torflex® Application Information

Full Load Dimensions

Dimensions are for low profile, top mount only. High profile brackets are .75" higher. Side mount is .31" higher.
Allow 3" bump clearance from full load.

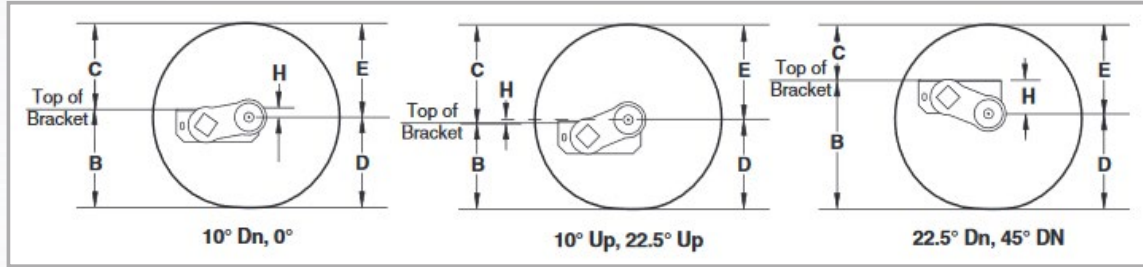

Start Angle

| Tire | 45° Down | | | | | 32° Down | | | | | 22.5° Down | | |
|-------------|----------|------|-----|------|------|----------|------|-----|------|------|------------|------|------|
| | D | E | H | B | C | D | E | H | B | C | H | B | C |
| LT235/85R16 | 14.3 | 15.4 | 4.3 | 18.6 | 11.1 | 14.3 | 15.4 | 3.0 | 17.3 | 12.4 | 2.0 | 16.3 | 13.4 |
| 215/75R17.5 | 14.0 | 15.3 | 4.6 | 18.6 | 10.7 | 14.0 | 15.3 | 3.2 | 17.2 | 12.1 | 2.3 | 16.3 | 13.0 |

Columns D and E are dimensional examples only. D - Static Loaded Radius E - Inflated Radius

| Tire | 10° Down | | | 0° | | | 10° Up | | | 22.5° Up | | |
|-------------|----------|------|------|------|------|------|--------|------|------|----------|------|------|
| | H | B | C | H | B | C | H | B | C | H | B | C |
| LT235/85R16 | 0.7 | 15.0 | 14.7 | -0.3 | 14.0 | 15.7 | -1.2 | 13.1 | 16.6 | -2.5 | 12.1 | 17.6 |
| 215/75R17.5 | 1.0 | 15.0 | 14.3 | -0.1 | 13.9 | 15.4 | -1.0 | 13.0 | 16.3 | -2.0 | 12.0 | 17.3 |

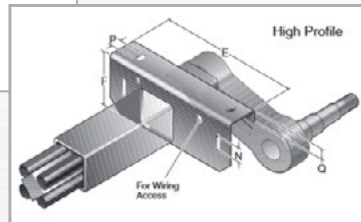
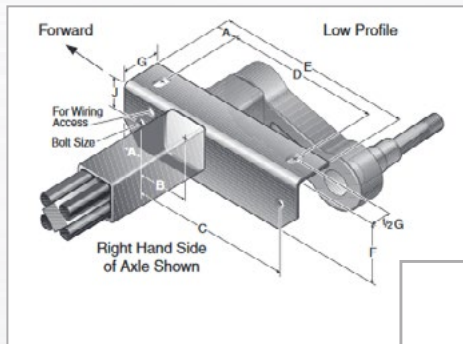

#12 Bracket Dimensions

| | Low | High |
|-----------|-----------|-------|
| A | 1.25 | 1.25 |
| B | 3.50 | 3.50 |
| C | 9.50 | 9.50 |
| D | 9.00 | 9.00 |
| E | 12.00 | 12.00 |
| F | 4.37 | 5.12 |
| G | 2.50 | 2.50 |
| J | 2.06 | 2.06 |
| N | --- | 1.03 |
| P | --- | 1.00 |
| Q | --- | 1.00 |
| Bolt Size | 5/8" bolt | |
| Tube Size | 3.50 | 3.50 |

#12 Overhang Overall

| Spindle | Min. | Max. |
|----------|--------|--------|
| Short | 14.00" | 30.40" |
| Standard | 15.00" | 30.40" |

8000 LBS CAPACITY

| Bolt Pattern | Axle Tube | Drop | Brake | Stud | Spindle |
|--------------|-----------|------|--------------------------------------|---------------|--------------|
| 8 - 6.50" | 3 1/2" | 4" | 12 1/4" x 2 1/2" 12 1/4" x 3 3/8" | 5/16" or 5/8" | #42 X-Flange |

Torflex® Application Information

Full Load Dimensions

Dimensions are for low profile, top mount only. High profile brackets are .75" higher. Side mount is .31" higher.
Allow 3" bump clearance from full load.

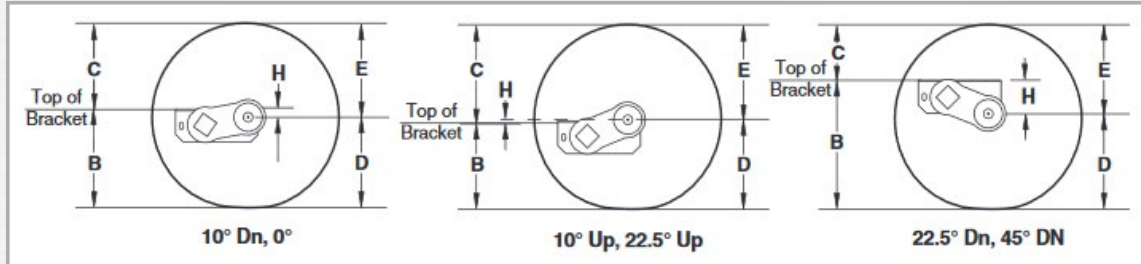

Start Angle

| Tire | 45° Down | | | | | 32° Down | | | | | 22.5° Down | | |
|-------------|----------|------|-----|------|------|----------|------|-----|------|------|------------|------|------|
| | D | E | H | B | C | D | E | H | B | C | H | B | C |
| LT235/85R16 | 14.3 | 15.4 | 4.3 | 18.6 | 11.1 | 14.3 | 15.4 | 3.0 | 17.3 | 12.4 | 2.0 | 16.3 | 13.4 |
| 215/75R17.5 | 14.0 | 15.3 | 4.6 | 18.6 | 10.7 | 14.0 | 15.3 | 3.2 | 17.2 | 12.1 | 2.3 | 16.3 | 13.0 |

Columns D and E are dimensional examples only. D - Static Loaded Radius E - Inflated Radius

| Tire | 10° Down | | | 0° | | | 10° Up | | | 22.5° Up | | |
|-------------|----------|------|------|------|------|------|--------|------|------|----------|------|------|
| | H | B | C | H | B | C | H | B | C | H | B | C |
| LT235/85R16 | 0.7 | 15.0 | 14.7 | -0.3 | 14.0 | 15.7 | -1.2 | 13.1 | 16.6 | -2.5 | 12.1 | 17.6 |
| 215/75R17.5 | 1.0 | 15.0 | 14.3 | -0.1 | 13.9 | 15.4 | -1.0 | 13.0 | 16.3 | -2.0 | 12.0 | 17.3 |

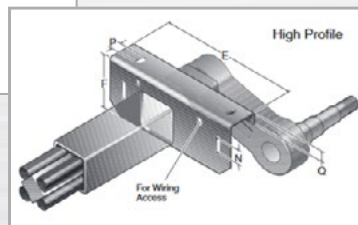
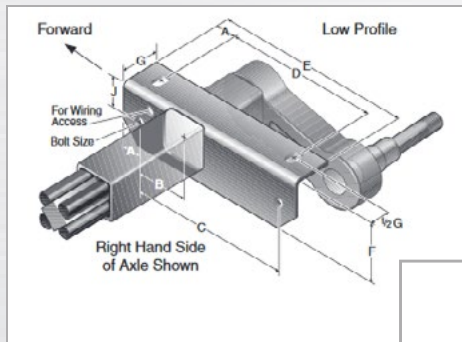

#13 Bracket Dimensions

| | Low | High |
|-----------|-----------|-------|
| A | 1.22 | 1.22 |
| B | 3.63 | 3.63 |
| C | 10.56 | 10.56 |
| D | 10.56 | 10.56 |
| E | 13.00 | 13.00 |
| F | 4.81 | 5.50 |
| G | 2.50 | 2.50 |
| J | 2.25 | 2.25 |
| L | 7.26 | 7.26 |
| P | --- | 1.00 |
| Q | --- | 1.00 |
| Bolt Size | 5/8" bolt | |
| Tube Size | 3.88 | 3.88 |

#13 Overhang Overall

| Spindle | Min. | Max. |
|----------|--------|--------|
| Short | 17.00" | 43.00" |
| Standard | 18.00" | 43.00" |

#13N Overhang Overall

| Spindle | Min. | Max. |
|----------|--------|--------|
| Standard | 14.15" | 16.95" |

AXLES AND COMPONENTS

10,000 LBS CAPACITY

| Bolt Pattern | Axle Tube | Type | Brake | Spring Width | Stud | Spindle |
|--------------|-----------|--------------|------------------|--------------|------|---------|
| 8 - 6.50" | 5" | General Duty | 12 1/4" x 3 3/8" | 2 1/2" | 5/8" | #99 |
| 8 - 6.50" | 5" | Heavy Duty | 12 1/4" x 4" | 3" | 5/8" | #120 |

Torflex® Application Information

Full Load Dimensions

Dimensions are for high profile, top mount only. Side mount is .31" higher.
Allow 3" bump clearance from full load.

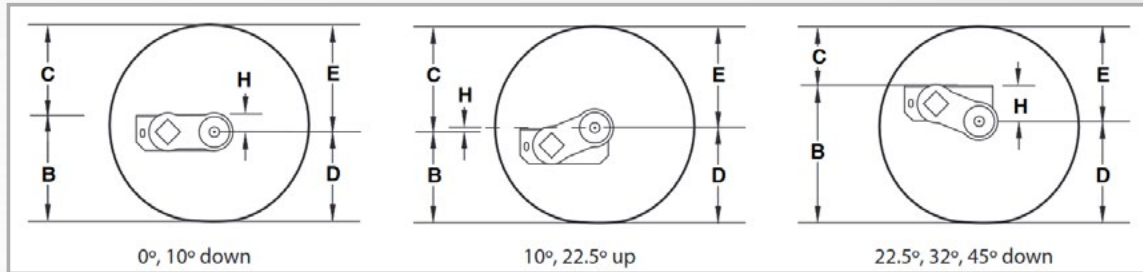

Start Angle

| Tire | 45° Down | | | | | 32° Down | | | 22.5° Down | | |
|-------------|----------|------|-----|------|------|----------|------|------|------------|------|------|
| | D | E | H | B | C | H | B | C | H | B | C |
| LT235/85R16 | 14.3 | 15.4 | 5.2 | 19.5 | 10.2 | 3.9 | 18.2 | 11.4 | 2.9 | 17.2 | 12.5 |
| 215/75R17.5 | 14.0 | 15.3 | 5.2 | 19.2 | 10.1 | 3.9 | 17.9 | 11.3 | 2.9 | 16.9 | 12.4 |
| 235/75R17.5 | 14.3 | 15.7 | 5.2 | 19.5 | 10.5 | 3.9 | 18.2 | 11.7 | 2.9 | 17.2 | 12.8 |

Columns D and E are dimensional examples only. D - Static Loaded Radius E - Inflated Radius

| Tire | 10° Down | | | 0° | | | 10° Up | | | 22.5° Up | | |
|-------------|----------|------|------|-----|------|------|--------|------|------|----------|------|------|
| | H | B | C | H | B | C | H | B | C | H | B | C |
| LT235/85R16 | 1.6 | 15.9 | 13.8 | 0.6 | 14.9 | 14.8 | -0.3 | 14.0 | 15.7 | -1.3 | 13.0 | 16.7 |
| 215/75R17.5 | 1.6 | 15.6 | 13.7 | 0.6 | 14.6 | 14.7 | -0.3 | 13.7 | 15.6 | -1.3 | 12.7 | 16.6 |
| 235/75R17.5 | 1.6 | 15.9 | 14.1 | 0.6 | 14.9 | 15.1 | -0.3 | 14.0 | 16.0 | -1.3 | 13.0 | 17.0 |

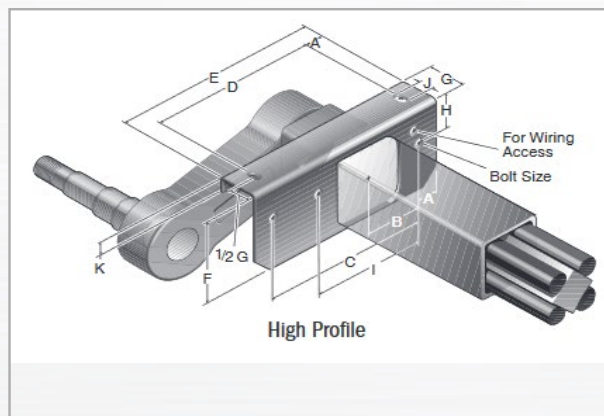

#13D & #13G Bracket Dimensions

| | |
|-----------|-----------|
| A | 1.22 |
| B | 3.63 |
| C | 10.56 |
| D | 10.56 |
| E | 13.00 |
| F | 5.50 |
| G | 2.50 |
| J | 2.25 |
| L | 7.26 |
| P | 1.00 |
| Q | 1.00 |
| Bolt Size | 5/8" bolt |
| Tube Size | 3.88 |

Overhang Per Side

| Spindle | Min. | Max. | Brake |
|----------------|--------|--------|------------------|
| #13D | 12.25" | 17.20" | 12 1/4" x 4" |
| #13G one-piece | 10.11" | 17.20" | 12 1/4" x 3 3/8" |
| #13G two-piece | 11.35" | 17.20" | 12 1/4" x 3 3/8" |

Note: Dual wheel not available for #13G one-piece. One-piece hub and drum is not interchangeable with the two-piece hub and drum.

12,000 LBS CAPACITY

| Bolt Pattern | Axle Tube | Type | Brake | Spring Width | Stud | Spindle |
|--------------|-----------|------------|--------------|--------------|------|---------|
| 8 - 6.50" | 5" | Heavy Duty | 12 1/4" x 5" | 3" | 5/8" | #120 |

15,000 LBS CAPACITY

| Bolt Pattern | Axle Tube | Type | Brake | Spring Width | Stud | Spindle |
|--------------|-----------|------------|--------------|--------------|------|---------|
| 8 - 275mm | 5" | Heavy Duty | 12 1/4" x 5" | 3" | 5/8" | #120 |

Note: 15K axle not available in Torflex.

Torflex® Application Information

Full Load Dimensions

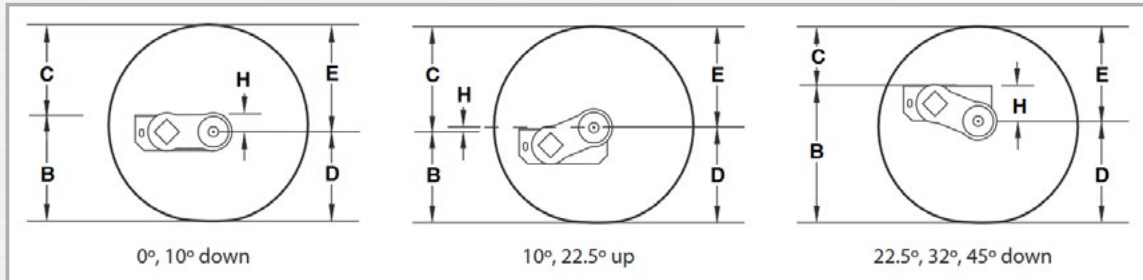

Start Angle

| Tire | 45° Down | | | | | 32° Down | | | 22.5° Down | | |
|-------------|----------|------|-----|------|------|----------|------|------|------------|------|------|
| | D | E | H | B | C | H | B | C | H | B | C |
| LT235/85R16 | 14.3 | 15.4 | 5.7 | 20.0 | 9.7 | 4.4 | 18.7 | 11.0 | 3.4 | 17.7 | 12.0 |
| 215/75R17.5 | 14.0 | 15.3 | 5.7 | 19.7 | 9.6 | 4.4 | 18.4 | 10.9 | 3.4 | 17.4 | 11.9 |
| 235/75R17.5 | 14.3 | 15.7 | 5.7 | 20.0 | 10.0 | 4.4 | 18.7 | 11.3 | 3.4 | 17.7 | 12.3 |

Columns D and E are dimensional examples only. D - Static Loaded Radius E - Inflated Radius

| Tire | 10° Down | | | 0° | | | 10° Up | | | 22.5° Up | | |
|-------------|----------|------|------|-----|------|------|--------|------|------|----------|------|------|
| | H | B | C | H | B | C | H | B | C | H | B | C |
| LT235/85R16 | 2.1 | 16.4 | 13.3 | 1.1 | 15.4 | 14.3 | -0.2 | 14.5 | 15.2 | -0.8 | 13.5 | 16.2 |
| 215/75R17.5 | 2.1 | 16.1 | 13.2 | 1.1 | 15.1 | 14.2 | -0.2 | 14.2 | 15.1 | -0.8 | 13.2 | 16.1 |
| 235/75R17.5 | 2.1 | 16.4 | 13.6 | 1.1 | 15.4 | 14.6 | -0.2 | 14.5 | 15.5 | -0.8 | 13.5 | 16.5 |

#14 Bracket Dimensions

| | |
|-----------|-----------|
| A | 4.50 |
| B | 9.00 |
| C | 12.00 |
| D | 4.50 |
| E | 2.44 |
| F | 2.50 |
| Bolt Size | 3/4" bolt |
| Tube Size | 4.25 |

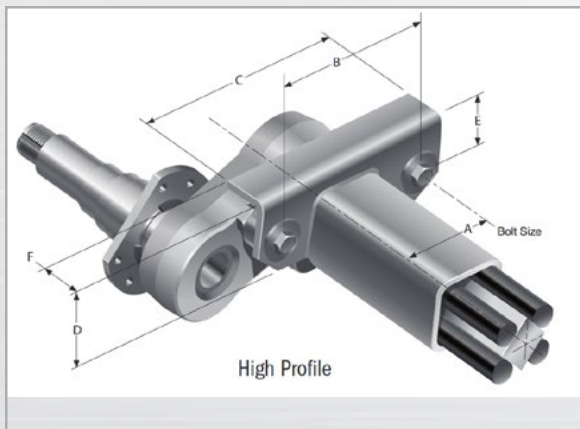

Overhang Per Side

| Spindle | Min. | Brake |
|---------|--------|------------------|
| #14 | 12.75" | 12 1/4" x 5" |
| #14T | 9.89" | 12 1/4" x 3 3/8" |
| #14 | 9.19" | Disc |

Note: One-piece hub and drum is not interchangeable with the two-piece hub and drum.

Beam Capacity **

| Model No. | Beam | Brake | Highway w Leaf Springs | Air Ride Suspension |
|-----------|----------------|--------------|------------------------|---------------------|
| D-2L12 | 5" Light Wall | 12 ¼" x 7 ½" | 22,500 Lbs. | N/A + |
| D-2M12 | 5" Medium Wall | 12 ¼" x 7 ½" | 25,000 Lbs. | 22,500 Lbs. |
| D-2H12 | 5" Heavy Wall | 12 ¼" x 7 ½" | 27,500 Lbs. | 25,000 Lbs. |
| D-2L16 | 5" Light Wall | 16 ½" x 7" | 22,500 Lbs. | N/A + |
| D-2M16 | 5" Medium Wall | 16 ½" x 7" | 25,000 Lbs. | 22,500 Lbs. |
| D-2H16 | 5" Heavy Wall | 16 ½" x 7" | 27,500 Lbs. | 25,000 Lbs. |

** Allowable use of axle capacity ratings (type of service and track/spring center overhang dimension, etc) and components vary with application.

+ Light wall tube on models D-2L12 and D-2L16 is **not** approved for axles equipped with air ride suspensions.

Available Axle Tracks

Tracks are available from 48" to 124"

Brake Performance

The following brake models meet or exceed requirements set forth by Federal Motor Vehicle Safety Standards 121 when tested under the following conditions:

| Brake Size | Wheel Load *(lbs.) | Rolling Radius (in.) | A.L. Factor (consisting of) |
|--------------|-----------------------|-------------------------|----------------------------------|
| 12 ¼" x 7 ½" | 10,000 | 15.7 | Type 30 A/C 6" Slack Adjuster |
| 16 ½" x 7" | 12,500 | 19.6 | Type 30 A/C 6" Slack Adjuster |

* Wheel Load per wheel end

The permitted use of axles and components, including the capacity ratings that are shown, vary with application and type of service. The capacities indicated for tires, wheels and axles should be use for general guidelines only.

SPINDLES

ROUND E-Z Lube® SPINDLES

| Part Number | Diameter | Type | Flange | Capacity (lbs) |
|-------------|----------|------|--------|----------------|
| 2-160-21 | 1.25" | D20 | - | 1000 |
| 2-162-22 | 1.75" | #84 | 4 | 1750 |
| 2-161-22 | 2.25" | #42 | 5 | 3000 |



Section B

Suspensions and Components

| | |
|-----------------------------------------------------|----------|
| Hangers, Equalizer Bars, U-Bolts | B-1 |
| Tie Plates, Suspension Bolts, Suspension Nuts | B-2 |
| Double Eye, Slipper, Tandem Dual Springs | B-2, B-3 |
| Bushings, Spring Seats | B-3 |
| 10K Suspension Components | B-4 |
| 10K HD - 15K Suspension Components | B-5 |
| HDSS Suspension Components..... | B-6 |

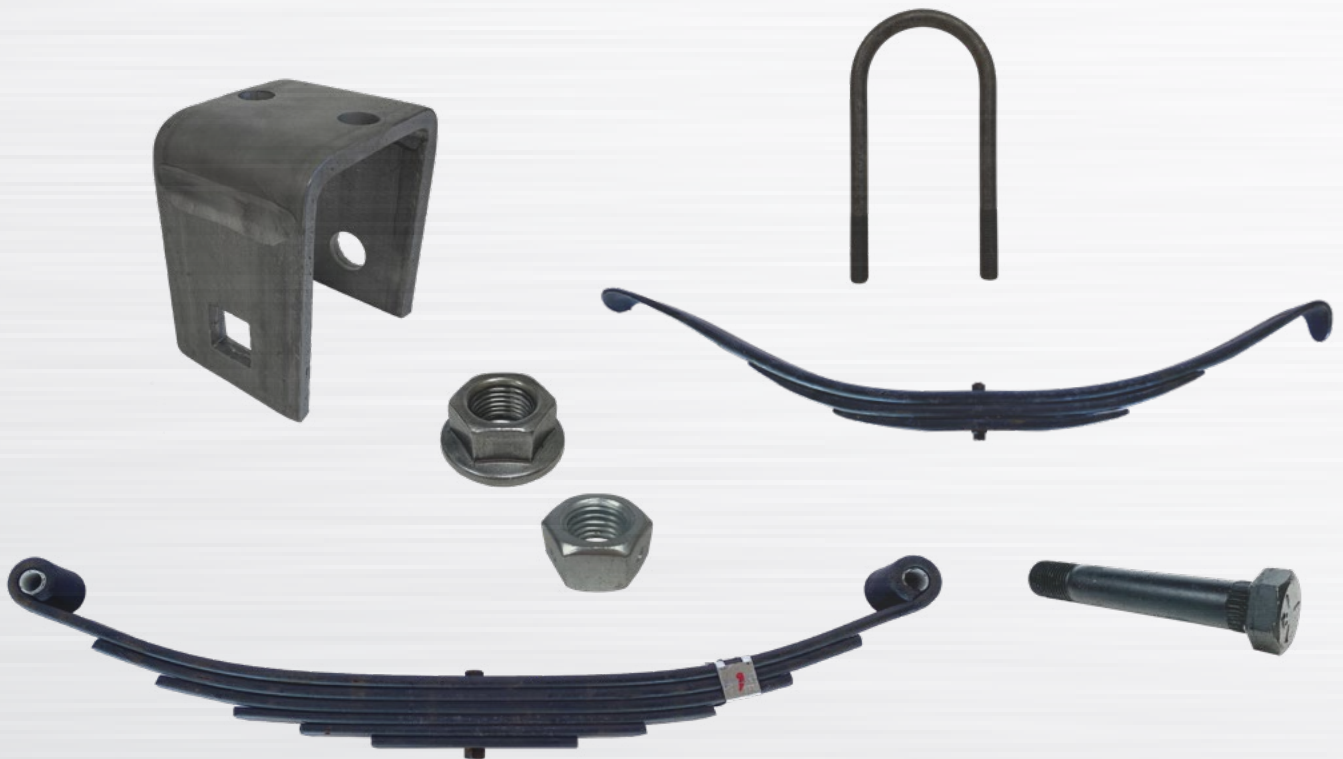

HANGERS

| Part Number | Spring Width | Working Height | Overall Height | Bolt Size | Material |
|-------------|--------------|----------------|----------------|-----------|----------|
| 41013 | 1.75" | 1.5" | 2 1/8" | 9/16" | 4 ga |
| 93003-3X | 1.75" | 1.25" | 2 1/4" | 9/16" | 4 ga |
| 28-1 | 1.75" | 2.50" | 3" | 9/16" | 4 ga |
| 28-5 | 1.75" | 3.25" | 3 7/8" | 9/16" | 4 ga |
| 30-37 | 1.75" | - | 1 1/4" | 9/16" | 4 ga |
| 72-1584-3 | 2" | 3.75" | 4 1/4" | 9/16" | 5/16" |
| 72-1586-3 | 2" | 3.50" | 4 1/2" | 7/8" | 3/8" |
| 72-1585-3 | 2" | 5" | 6" | 9/16" | 5/16" |
| 18-11 | - | 2 5/8" | 4" | 9/16" | 4 ga |
| 18-12 | - | 3 1/8" | 4 1/2" | 9/16" | 4 ga |



18-12



18-11



30-37



72-1585-3



41013



93003-3X



28-1



28-5



72-1586-3

EQUALIZER BARS

| Part Number | Description |
|-------------|-----------------------------------------------------------------------------------|
| E1 | Cast Equalizer Bar; 7.75" long with 9/16" Nylon Bushings; 1 3/4" Springs |
| EQ-104 | Cast Equalizer Bar; 5.75" long with 9/16" Nylon Bushings; 1 3/4" Springs |
| EQ-310 | Cast Equalizer Bar; 6.06" long with 9/16" Nylon Bushings; 4" Tall; 1 3/4" Springs |
| 5541 | Equalizer Bar for 2" Slipper Spring |
| 14-54 | Nylon Bushing; 9/16" |
| 14-90 | Nylon Bushing; 7/8" for 5541 Equalizer |



E1



EQ-104



EQ-310



5541



14-90



14-54

U-BOLTS

| Part Number | Tube Size | Diameter | Length |
|-------------|-----------|------------|--------|
| 11-54 | 1.75" | 5/8" - 24 | 4.03" |
| 11-2 | 2.00" | 9/16" - 18 | 5.75" |
| 11-21 | 2.38" | 1/2" - 20 | 5.50" |
| 11-18 | 3.00" | 1/2" - 20 | 7.05" |
| 11-916 | 3.00" | 9/16" - 18 | 7.05" |
| 11-64 | 4.00" | 5/8" - 11 | 8.15" |
| 11-77 | 5.00" | 5/8" - 11 | 8.94" |
| 11-70 | 5.00" | 3/4" - 10 | 9.61" |
| 781610 | 5.00" | 7/8" - 14 | 11.75" |
| 11-94 | 5.00" | 3/4" - 10 | 11.03" |



11-21



11-2

SUSPENSIONS AND COMPONENTS

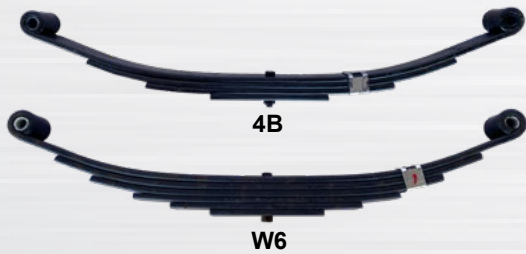
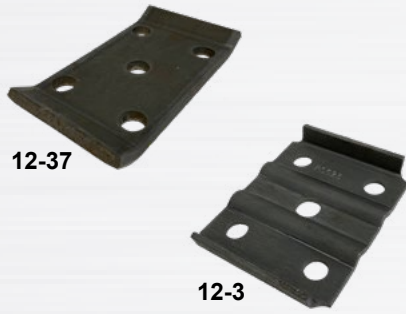

TIE PLATES

| Part Number | Tube Size | Spring Width | U-Bolt |
|-------------|-----------|--------------|---------------|
| 12-40 | 1.75" | 1.75" | 3/8" |
| 12-99 | 2.00" | 1.75" | 9/16" |
| 12-3 | 2.38" | 1.75" | 1/2" |
| 12-2 | 3.00" | 2.00" | 1/2" or 9/16" |
| 12-37 | 3.50" | 2.00" | 9/16" |
| 12-42 | 4.00" | 2.00" | 5/8" |
| 12-49 | 5.00" | 2.50" | 5/8" |
| 12-46 | 5.00" | 3.00" | 3/4" |
| 12-68-1 | 5.00" | 3.00" | 3/4" HDSS |

SUSPENSION BOLTS

| Part Number | Description | Diameter | Length |
|-------------|-----------------------------------|------------|--------|
| 7-3 | Shackle Bolt for 1.75" Springs | 3/16" - 18 | 3.00" |
| 7-17 | Spring Eye Bolt for 2.00" Springs | 3/16" - 18 | 3.50" |
| 7-1 | Carriage Bolt for 2.00" Equalizer | 7/8" - 9 | 4.62" |

SUSPENSION NUTS

| Part Number | Type | Thread |
|-------------|------------------------------|------------|
| 6-129 | Hex Nut | 1/2" - 20 |
| 6-99F | Hex Flange Nut | 1/2" - 20 |
| 6-98F | Hex Flange Nut | 9/16" - 18 |
| 6-7 | Hex Lock Nut | 9/16" - 18 |
| 6-111 | Hex Lock Nut | 7/8" - 9 |
| 3500 | Lock Washer for Hutch U-Bolt | 7/8" |
| 3404 | Nut for Hutch U-Bolt | 7/8" |

DOUBLE EYE SPRINGS

| Part Number | Leaves | Spring Width | Spring Length | Capacity (lb) |
|-------------|--------|--------------|---------------|---------------|
| 72-17 | 3 | 1.75" | 20.38" | 1000 |
| 4B | 4 | 1.75" | 25.25" | 1750 |
| W5 | 5 | 1.75" | 25.25" | 3000 |
| W6 | 6 | 1.75" | 25.25" | 3500 |

SLIPPER SPRINGS

| Part Number | Leaves | Spring Width | Spring Length | Capacity (lb) |
|-------------|--------|--------------|---------------|---------------|
| 5226 | 5 | 2.00" | 26.50" | 3400 |
| 5115 | 6 | 2.00" | 29.50" | 4000 |
| 5116 | 6 | 2.00" | 26.50" | 3750 |
| 8536 | 8 | 2.00" | 29.50" | 5200 |

TANDEM DUAL SLIPPER SPRINGS

| Part Number | Leaves | Spring Width | Spring Length | Capacity (lb) | Description |
|-------------|--------|--------------|---------------|---------------|---------------|
| 72-80 | 5 | 2.50" | 30.00" | 5000 | 10K GD Dexter |
| 72-43-1 | 5 | 3.00" | 30.00" | 5000 | 10K HD Dexter |
| 72-44-1 | 6 | 3.00" | 30.00" | 6000 | 12K Dexter |
| 72-45-1 | 7 | 3.00" | 30.00" | 7500 | 15K Dexter |
| 72-48 | 3 | 3.00" | 43.75" | 11200 | Hutch or HDSS |
| 8131 | 5 | 2.50" | 32.50" | 5000 | 10K ALKO |
| 8132 | 6 | 2.50" | 32.50" | 6250 | 12K ALKO |



72-80



72-48

BUSHINGS

| Part Number | Length | Inner Diameter | Outer Diameter | Material |
|-------------|--------|----------------|----------------|--------------|
| 14-54 | 1.70" | 0.57" | 0.69" | Nylon |
| 14-54-1 | 2.20" | 0.57" | 1.31" | Neopreme |
| 14-112 | 2.50" | 0.75" | 2.00" | Rubber |
| 14-67 | 2.50" | 0.75" | 1.00" | Bronze |
| 14-111 | 2.50" | 0.88" | 1.00" | Bronze |
| 14-69 | 3.12" | 1.00" | 2.06" | Rubber/Steel |
| 14-90 | 2.88" | 0.88" | 1.07" | Nylon |



14-54



14-90

SPRING SEATS

| Part Number | Tube Size | Width | Height | Length |
|---------------------|-----------|-------|--------|--------|
| 3-49 | 1.75" | 1.75" | 0.63" | 2.25" |
| 3-43 | 2.38" | 1.62" | 0.62" | 4.00" |
| 3-1 | 3.00" | 1.88" | 0.62" | 4.00" |
| 3-1-02 (reinforced) | 3.00" | 1.88" | 0.62" | 4.00" |
| 3-48 | 3.50" | 1.88" | 0.62" | 4.00" |
| 3-72 | 5.00" | 2.50" | 0.50" | 6.00" |
| 3-66 | 5.00" | 3.00" | 0.50" | 6.00" |



3-48



3-49



3-43

ADJUSTABLE SPRING SEATS

| Part Number | Tube Size | Width | Height | Length |
|-------------|-----------|-------|--------|--------|
| 3-173-3 | 5.00" | 2.50" | .50" | 5.75" |
| 3-173-1 | 5.00" | 3.00" | .50" | 5.75" |

Description

| | |
|-------|----------------------------------------|
| 77-17 | Slider Bar for 2.50" & 3.00" |
| 7-97 | Hex Head Bolt; 1/2 - 20 X 1.75 Grade 5 |



3-173-1



77-17

7-97

SUSPENSIONS AND COMPONENTS

Kits for 2 1/2" Wide Springs 3/4" Spring Eye Bolts

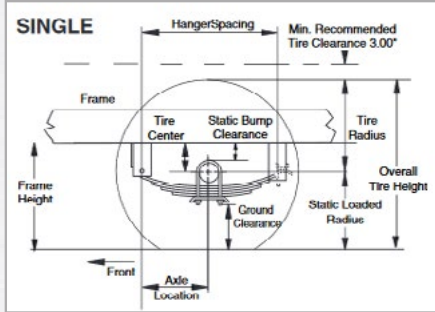

| 10K GD TANDEM AXLE | | | |
|-----------------------|-----------|-----------|-----------|
| | HAP-258-1 | HAP-258-2 | HAP-258-3 |
| Front Hanger Spacing | 33.0 | 35.1 | 38.3 |
| Rear Hanger Spacing | 32.4 | 34.6 | 37.7 |
| Static Bump Clearance | 1.7 | 1.7 | 1.7 |
| Tire Center | 4.8 | 4.8 | 4.8 |
| Axle Location | 14.0 | 14.0 | 14.0 |
| Front Axle Spacing | 38.0 | 42.3 | 48.5 |

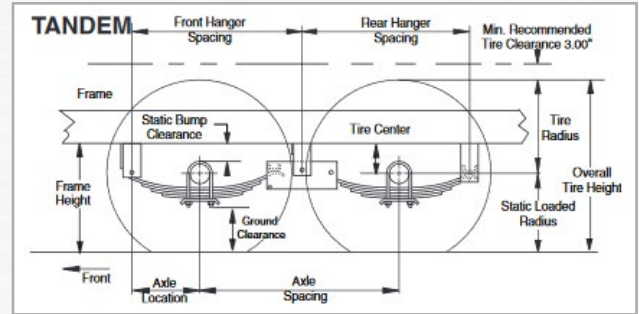

| 10K GD SINGLE AXLE HAP-158 | | |
|----------------------------|----------|-------------------|
| Part Number | Quantity | Description |
| 28-74-2 | 2 | Hanger |
| 30-61-1 | 2 | Rear Hanger |
| 7-264 | 2 | Spring Eye Bolt |
| 6-113 | 2 | Locknut |
| 59-203 | 1 | Instruction Sheet |
| Front Hanger Spacing | | 27.4 |
| Static Bump Clearance | | 1.9 |
| Tire Center | | 5.0 |
| Axle Location | | 14.0 |

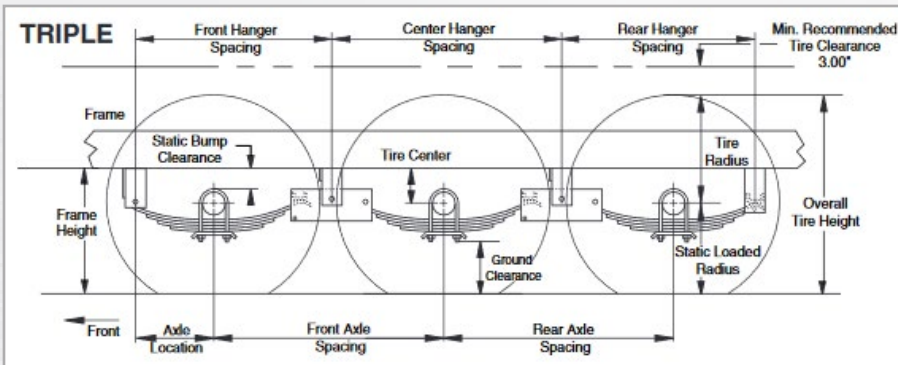

| 10K GD TRIPLE AXLE | | | |
|-----------------------|-----------|-----------|-----------|
| | HAP-258-1 | HAP-258-2 | HAP-258-3 |
| Front Hanger Spacing | 33.00 | 35.1 | 38.3 |
| Center Hanger Spacing | 38.0 | 42.3 | 48.5 |
| Rear Hanger Spacing | 32.4 | 34.6 | 37.7 |
| Static Bump Clearance | 1.7 | 1.7 | 1.7 |
| Tire Center | 4.8 | 4.8 | 4.8 |
| Axle Location | 14.0 | 14.0 | 14.0 |
| Front Axle Spacing | 38.0 | 42.3 | 48.5 |
| Rear Axle Spacing | 38.0 | 42.3 | 48.5 |

| 10K GD 38" MULTI-AXLE CONVERSION KIT HAP-258-1 | | |
|------------------------------------------------|----------|-------------------|
| Part No | Quantity | Description |
| 6-112 | 2 | Locknut |
| 6-113 | 2 | Locknut |
| 7-264 | 2 | Spring Eye Bolt |
| 7-169 | 2 | Equalizer Bolt |
| 13-139-3 | 2 | Equalizer |
| 29-42-2 | 2 | Center Hanger |
| 59-203 | 1 | Instruction Sheet |

| 10K GD 42.25" MULTI-AXLE CONVERSION KIT HAP-258-2 | | |
|---------------------------------------------------|----------|-------------------|
| Part No | Quantity | Description |
| 6-112 | 2 | Locknut |
| 6-113 | 2 | Locknut |
| 7-264 | 2 | Spring Eye Bolt |
| 7-169 | 2 | Equalizer Bolt |
| 13-139-3 | 2 | Equalizer |
| 29-42-2 | 2 | Center Hanger |
| 59-203 | 1 | Instruction Sheet |

| 10K GD 48.5" MULTI-AXLE CONVERSION KIT HAP-258-3 | | |
|--------------------------------------------------|----------|-------------------|
| Part No | Quantity | Description |
| 6-112 | 2 | Locknut |
| 6-113 | 2 | Locknut |
| 7-264 | 2 | Spring Eye Bolt |
| 7-169 | 2 | Equalizer Bolt |
| 13-139-3 | 2 | Equalizer |
| 29-42-2 | 2 | Center Hanger |
| 59-203 | 1 | Instruction Sheet |

| 10K GD AXLE ASSEMBLIES | | | |
|------------------------------------------------------------|------------------------------|------------------------------|------------------------------|
| | 38" | 42.25" | 48.50" |
| <i>For single axle assemblies use (1) HAP-158</i> | | | |
| Tandem | (1) HAP-158 (1) HAP-258-1 | (1) HAP-158 (1) HAP-258-2 | (1) HAP-158 (1) HAP-258-3 |
| Triple | (1) HAP-158 (2) HAP-258-1 | (1) HAP-158 (2) HAP-258-2 | (1) HAP-158 (2) HAP-258-3 |
| All dimensions are for underslung spring orientation only. | | | |

SUSPENSIONS AND COMPONENTS

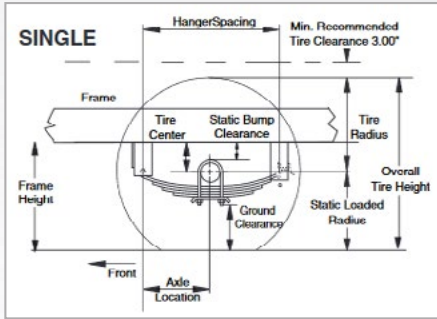

10-15K SINGLE AXLE HAP-103

| Part Number | Quantity | Description |
|-----------------------|----------|-------------------|
| 28-67-4 | 2 | Front Hanger |
| 30-66-1 | 2 | Rear Hanger |
| 7-169 | 2 | Spring Eye Bolt |
| 7-95 | 2 | Keeper Bolt |
| 6-46 | 2 | Locknut |
| 6-112 | 2 | Locknut |
| 59-203 | 1 | Instruction Sheet |
| Front Hanger Spacing | | 27.4 |
| Static Bump Clearance | | 2.9 |
| Tire Center | | 6.0 |
| Axle Location | | 14.0 |

| | HAP-203-1 | HAP-203-2 | HAP-203-3 |
|-----------------------|-----------|-----------|-----------|
| Front Hanger Spacing | 33.0 | 35.1 | 38.3 |
| Rear Hanger Spacing | 32.4 | 34.6 | 37.7 |
| Static Bump Clearance | 2.2 | 2.2 | 2.2 |
| Tire Center | 5.3 | 5.3 | 5.3 |
| Axle Location | 14.0 | 14.0 | 14.0 |
| Front Axle Spacing | 38.0 | 42.3 | 48.5 |

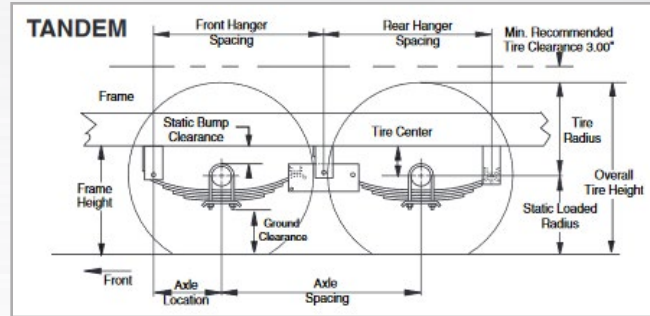

10-15K 48.5" MULTI-AXLE CONVERSION KIT HAP-203-3

| Part No | Quantity | Description |
|----------|----------|-------------------|
| 29-43-2 | 2 | Center Hanger |
| 13-109-3 | 2 | Equalizer |
| 7-169 | 2 | Spring Eye Bolt |
| 7-95 | 2 | Keeper Bolt |
| 7-170 | 2 | Equalizer Bolt |
| 6-46 | 2 | Locknut |
| 6-72 | 2 | Locknut |
| 6-112 | 2 | Locknut |
| 59-203 | 1 | Instruction Sheet |

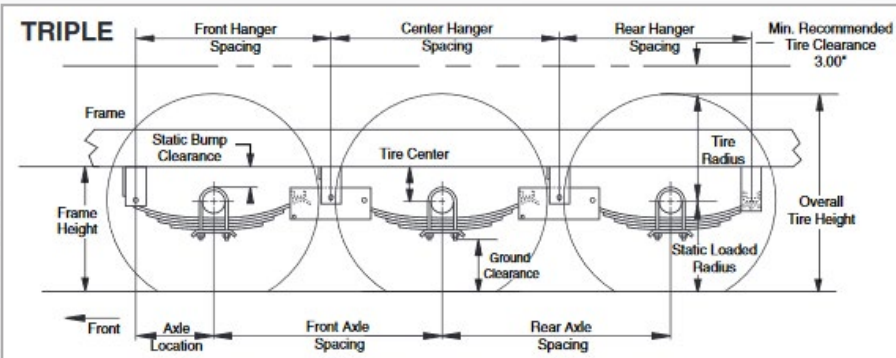

10-15K TRIPLE AXLE

| | HAP-203-1 | HAP-203-2 | HAP-203-3 |
|-----------------------|-----------|-----------|-----------|
| Front Hanger Spacing | 33.00 | 35.1 | 38.3 |
| Center Hanger Spacing | 38.0 | 42.3 | 48.5 |
| Rear Hanger Spacing | 32.4 | 34.6 | 37.7 |
| Static Bump Clearance | 2.0 | 2.0 | 2.0 |
| Tire Center | 5.1 | 5.1 | 5.1 |
| Axle Location | 14.0 | 14.0 | 14.0 |
| Front Axle Spacing | 38.0 | 42.3 | 48.5 |
| Rear Axle Spacing | 38.0 | 42.3 | 48.5 |

10-15K 42.25" MULTI-AXLE CONVERSION KIT HAP-203-2

| Part No | Quantity | Description |
|----------|----------|-------------------|
| 29-43-2 | 2 | Center Hanger |
| 13-108-3 | 2 | Equalizer |
| 7-169 | 2 | Spring Eye Bolt |
| 7-95 | 2 | Keeper Bolt |
| 7-170 | 2 | Equalizer Bolt |
| 6-46 | 2 | Locknut |
| 6-72 | 2 | Locknut |
| 6-112 | 2 | Locknut |
| 59-203 | 1 | Instruction Sheet |

10-15K 38" MULTI-AXLE CONVERSION KIT HAP-203-1

| Part No | Quantity | Description |
|----------|----------|-------------------|
| 29-43-2 | 2 | Center Hanger |
| 13-107-7 | 2 | Equalizer |
| 7-169 | 2 | Spring Eye Bolt |
| 7-95 | 2 | Keeper Bolt |
| 7-170 | 2 | Equalizer Bolt |
| 6-46 | 2 | Locknut |
| 6-72 | 2 | Locknut |
| 6-112 | 2 | Locknut |
| 59-203 | 1 | Instruction Sheet |

10-15K AXLE ASSEMBLIES

| | 38" | 42.25" | 48.50" |
|---------------------------------------------------|------------------------------|------------------------------|------------------------------|
| <i>For single axle assemblies use (1) HAP-103</i> | | | |
| Tandem | (1) HAP-103 (1) HAP-203-1 | (1) HAP-103 (1) HAP-203-2 | (1) HAP-103 (1) HAP-203-3 |
| Triple | (1) HAP-103 (2) HAP-203-1 | (1) HAP-103 (2) HAP-203-2 | (1) HAP-103 (2) HAP-203-3 |

All dimensions are for underslung spring orientation only.

SUSPENSIONS AND COMPONENTS

HDSS Underslung

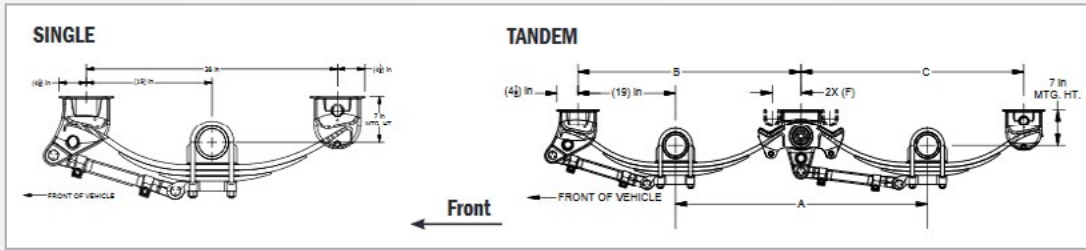

| Axle Spacing | A | B | C | F |
|--------------|----------|----------|----------|-----------|
| 49" | 49 3/16" | 43 1/2" | 43 1/2" | N/A |
| 54" | 54 7/32" | 46 1/32" | 46 7/32" | 8 3/8" |
| 60" | 60 7/32" | 49 1/32" | 49 7/32" | 11 15/32" |

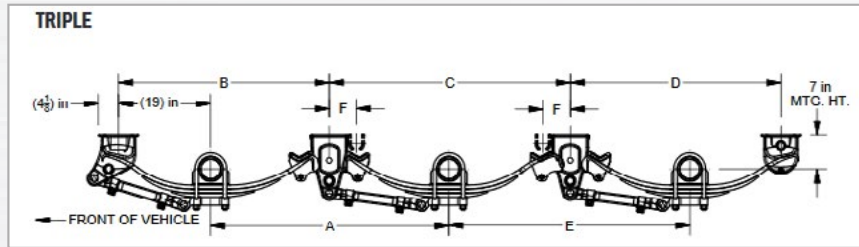

| Axle Spacing | A | B | C | D | E | F |
|--------------|----------|----------|---------|----------|---------|-----------|
| 49" | 49 3/16" | 43 1/2" | 49 3/4" | 43 1/2" | 49 3/4" | N/A |
| 54" | 54 7/32" | 46 1/32" | 54 3/4" | 46 7/32" | 54 3/4" | 8 3/8" |
| 60" | 60 7/32" | 49 1/32" | 60 3/4" | 49 7/32" | 60 3/4" | 11 15/32" |

10-25K SINGLE AXLE KIT CONTENTS

| Part No | Quantity | Description |
|---------|----------|--------------------------------------|
| 28-82-5 | 2 | Front Hanger |
| 30-75-5 | 2 | Rear Hanger |
| 62-1-1 | 1 | Track Rod Bushed Adj 19.25 |
| 62-11-1 | 1 | Track Rod Bushed Fixed 19.25 |
| 7-169 | 4 | Track Rod Bolt 1-8 x 5.50 UNC |
| 6-278 | 4 | Track Rod Locknut 1-8 UNC |
| 33-91 | 2 | Keeper Bolt Sleeve |
| 7-294 | 2 | Spring Keeper Bolt 5/8-18 x 4.50 UNF |
| 6-126 | 2 | Keeper Bolt Locknut 5/8-18 UNF |
| 59-918 | 1 | Instruction Sheet |

10-25K MULTI AXLE KIT CONTENTS

| Part No | Quantity | Description |
|----------|----------|-----------------------------------------|
| 29-44-1 | 2 | Center Hanger and EQ Assembly HAP-261-1 |
| 62-1-1 | 1 | Track Rod Bushed Adj 19.25 |
| 62-11-1 | 1 | Track Rod Bushed Fixed 19.25 |
| 29-49-1 | 2 | Center Hanger and EQ Assembly HAP-162-1 |
| 62-1-54 | 1 | Track Rod Bushed Adj 21.75 |
| 62-11-54 | 1 | Track Rod Bushed Fixed 21.75 |
| 29-49-2 | 2 | Center Hanger and EQ Assembly HAP-163-1 |
| 62-1-6 | 1 | Track Rod Bushed Adj 24.75 |
| 62-11-6 | 1 | Track Rod Bushed Fixed 24.75 |
| 7-169 | 4 | Track Rod Bolt 1-8 x 5.50 UNC |
| 6-278 | 4 | Track Rod Locknut 1-8 UNC |
| 33-91 | 4 | Keeper Bolt Sleeve |
| 7-294 | 4 | Spring Keeper Bolt 5/8-18 x 4.50 UNF |
| 6-126 | 4 | Keeper Bolt Locknut 5/8-18 UNF |
| 59-918 | 1 | Instruction Sheet |

SUSPENSION KITS

Order appropriate number of HAP kits for a complete suspension

| HDSS Underslung | | |
|-----------------|-----------|-----------|
| | HAP-161-1 | HAP-261-1 |
| 49" | | |
| Qty for Single | 1 | n/a |
| Qty for Tandem | 1 | 1 |
| Qty for Triple | 1 | 2 |
| 54" | | |
| Qty for Single | 1 | n/a |
| Qty for Tandem | 1 | 1 |
| Qty for Triple | 1 | 2 |
| 60" | | |
| Qty for Single | 1 | n/a |
| Qty for Tandem | 1 | 1 |
| Qty for Triple | 1 | 2 |

SUSPENSIONS AND COMPONENTS

Section C

Hubs and Components

Light Duty

| | |
|----------------------------|-----------|
| 1000-2200lb Capacity | C-1 |
| 2300-4000lb Capacity | C-2 |
| 4100-6000lb Capacity | C-3 |
| 5500-7000lb Capacity | C-4 & C-5 |
| 7200lb Capacity | C-6 & C-7 |
| 8000lb Capacity | C-8 & C-9 |

Medium Duty

| | |
|------------------------------|-------------|
| 9000-10000lb Capacity | C-10 & C-11 |
| 10000-15000lb Capacity | C-12 |

Heavy Duty 22.5K - 27.5K lb Capacity

| | |
|-------------------------------|----------------|
| 12 ¼" x 7 ½" Brake Size | C-13 & C-14 |
| 16 ½" x 7" Brake Size | C-15 thru C-17 |



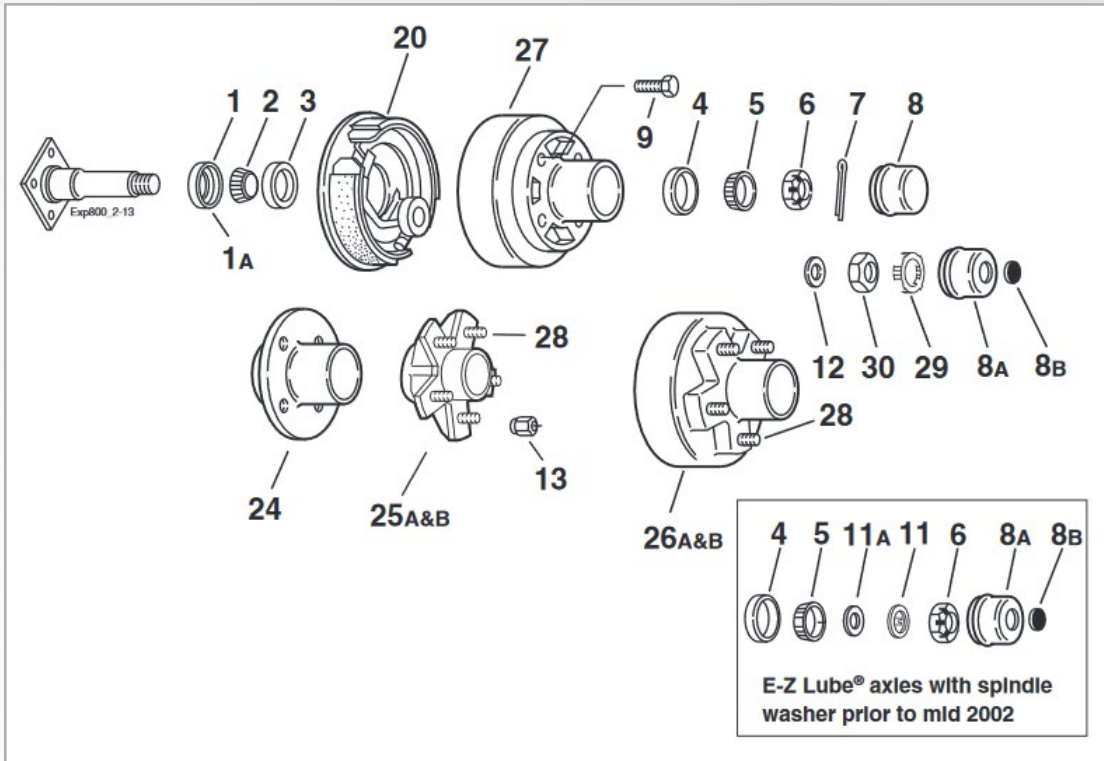

Grease Lube Parts

| Item | Part # | Description |
|------|----------|-------------------------------------------------|
| 1 | 10-9 | Grease Seal |
| 2 | L44649 | Inner Bearing Cone |
| 3 | L44610 | Inner Bearing Cup |
| 4 | L44610 | Outer Bearing Cone |
| 5 | L44649 | Outer Bearing Cone |
| 6 | 6-176 | Spindle Nut |
| 7 | 19-2 | Cotter Pin (Not used with E-Z Lube®) |
| 8 | 21-3 | Grease Cap |
| 8A | 21-41-1 | Grease Cap for E-Z Lube® |
| 8B | 85-1 | Rubber Plug for E-Z Lube® |
| 9 | 7-40 | Wheel Bolt |
| 11 | 5-101 | Tang Washer for E-Z Lube® (before 2002) |
| 11A | 5-151 | Spindle Washer for E-Z Lube® (before 2002) |
| 12 | 5-23 | Spindle Washer for E-Z Lube® (after 2002) |
| 29 | 6-190-00 | Spindle Nut Retainer for E-Z Lube® (after 2002) |
| 30 | 6-191-00 | Special Jam Nut for E-Z Lube® (after 2002) |

Brakes

| Item | Part # | Description |
|------|-----------------|---------------------------------------|
| 20 | 23-47 / 23-48 | LH/RH 7" x 1 1/4" Electric |
| ns | 23-103 / 23-104 | LH/RH 7" x 1 1/4" Electric w/ park |
| ns | 23-398 / 23-399 | LH/RH 7" x 1 1/4" Hydraulic Uni-Servo |

Hubs

| Item | Part # | Description | Bolt Circle |
|-----------------------|----------|---------------------------------------------------|-------------|
| Hubs and Drums | | | |
| ns | 8-173-16 | 1/2" Studs, elec. brakes ONLY | 4 on 4.00 |
| ns | 8-276-5 | 1/2" Studs, hyd. brakes ONLY | 4 on 4.00 |
| 26A | 8-257-5 | 1/2" Studs, elec. brakes ONLY | 5 on 4.50 |
| 26B | 8-271-7 | 1/2" Studs, hyd. brakes ONLY | 5 on 4.50 |
| 27 | 8-173-15 | 1/2" Tapped, elec. brakes ONLY | 4 on 4.00 |
| ns | 8-257-4 | 1/2" Tapped, elec. brakes ONLY | 5 on 4.50 |
| ns | 8-271-4 | 1/2" Tapped, hyd. brakes ONLY | 5 on 4.50 |
| Plain Hubs | | | |
| ns | 8-91-5 | 1/2" Studs | 4 on 4.00 |
| 24 | 8-91-4 | 1/2" Tapped | 4 on 4.00 |
| 25A | 8-259-05 | 1/2" Studs, 8"-12" wheel ONLY | 5 on 4.50 |
| | 8-259-5 | 1/2" Studs, 8"-12" wheel ONLY GAL-DEX® coated | 5 on 4.50 |
| 25B | 8-258-05 | 1/2" Studs, 13"-15" wheel ONLY | 5 on 4.50 |
| | 8-258-5 | 1/2" Studs, 13"-15" wheel ONLY GAL-DEX® coated | 5 on 4.50 |
| ns | 8-259-4 | 1/2" Tapped, 8"-12" wheel ONLY | 5 on 4.50 |
| ns | 8-258-4 | 1/2" Tapped, 13"-15" wheel ONLY | 5 on 4.50 |

Studs and Wheel Nuts

| Item | Part # | Description |
|------|--------|----------------------|
| 9 | 7-40 | 1/2-20 Wheel Bolt |
| 13 | 6-80 | 1/2-20 60° Cone Nut |
| 28 | 7-246 | 1/2-20 Press-In Stud |

NS - not shown
Note: Spindle is not available for resale

2300-4000 LBS CAPACITY D35, #10 545 and Other Hub Group

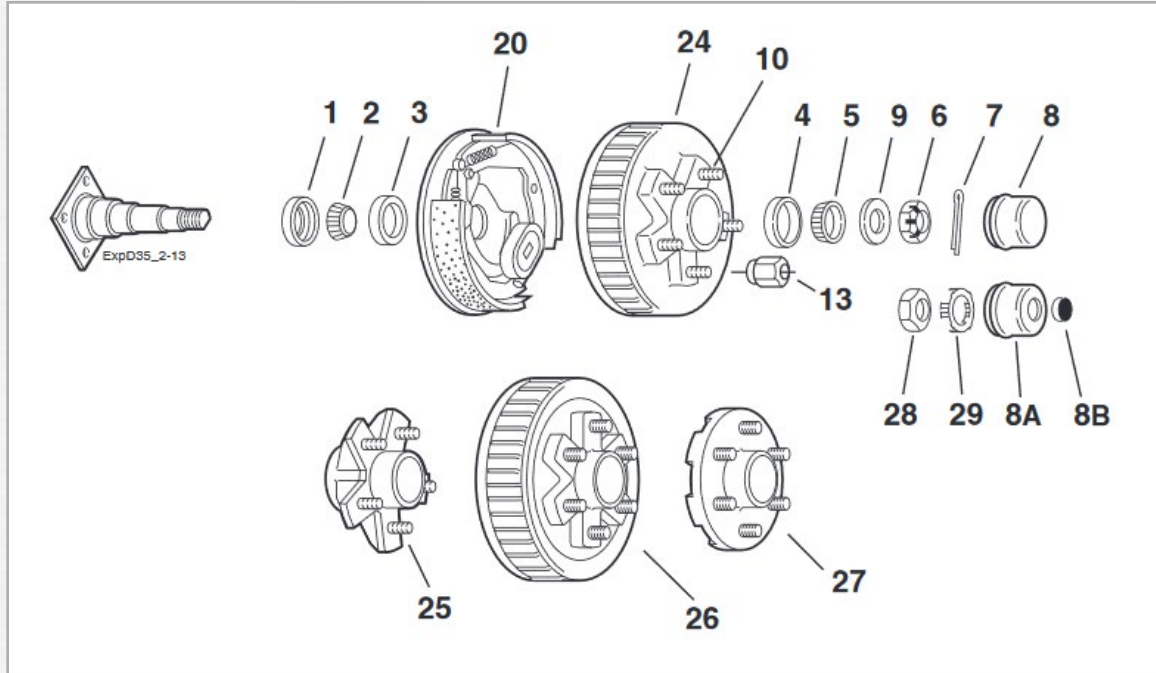

HUBS AND COMPONENTS

Grease Lube Parts

| Item | Part # | Description |
|------|----------|-------------------------------------------------|
| 1 | 10-4 | Grease Seal for E-Z Lube® |
| 2 | L68149 | Inner Bearing Cone |
| 3 | L68111 | Inner Bearing Cup |
| 4 | L44610 | Outer Bearing Cup |
| 5 | L44649 | Outer Bearing Cone |
| 6 | 6-176 | Spindle Nut |
| 7 | 19-2 | Cotter Pin |
| 8 | 21-3 | Grease Cap |
| 8A | 21-41-1 | Grease Cap for E-Z Lube® |
| 8B | 85-1 | Rubber Plug for E-Z Lube® |
| 9 | 5-23 | Spindle Washer |
| 28 | 6-191-00 | Special Jam Nut for E-Z Lube® (after 2002) |
| 29 | 6-190-00 | Spindle Nut Retainer for E-Z Lube® (after 2002) |

Hubs

| Item | Part # | Description | Bolt Circle |
|-----------------------|----------|-------------|-------------|
| Hubs and Drums | | | |
| 24 | 8-247-5 | ½" Stud | 5 on 4.50 |
| 24 | 8-249-7 | ½" Stud | 5 on 5.00 |
| 24 | 8-249-5 | ½" Stud | 5 on 5.50 |
| 24 | 8-247-12 | ½" Stud | 5 on 4.75 |
| 26 | 8-250-5 | ½" Stud | 6 on 5.50 |
| Plain Hubs | | | |
| 25 | 8-248-5 | ½" Stud | 5 on 4.50 |
| 25 | 8-248-1 | ½" Stud | 5 on 4.75 |
| 25 | 8-256-7 | ½" Stud | 5 on 5.00 |
| 25 | 8-256-5 | ½" Stud | 5 on 5.50 |
| 27 | 8-251-5 | ½" Stud | 6 on 5.50 |

10" x 2 ¼" Brakes

| Item | Part # | Description |
|------|-----------------------|----------------------------------------|
| ns | 23-468 / 23-469 | LH/RH Electric Nev-R-Adjust |
| 20 | 23-026 / 23-027 | LH/RH Electric |
| ns | 23-086 / 23-087 | LH/RH Electric w/park |
| ns | 23-312 / 23-313 | LH/RH Hydraulic Uni-servo |
| ns | 23-330 / 23-331 | LH/RH Hydraulic Uni-servo w/park |
| ns | 23-310 / 23-311 | LH/RH Hydraulic Duo-servo |
| ns | 23-400 / 23-401 | LH/RH Hydraulic Duo-servo w/park |
| ns | 23-344 / 23-345 | LH/RH Hydraulic Free Backing |
| ns | 23-344-01 / 23-345-01 | LH/RH Hydraulic FB Corrosion Resistant |

Studs and Wheel Nuts

| Item | Part # | Description |
|------|--------|-------------------------|
| 10 | 7-122 | ½-20 Pressed Wheel Stud |
| 13 | 6-80 | ½-20 60° Cone Nut |

NS - not shown

Note: Spindle is not available for resale

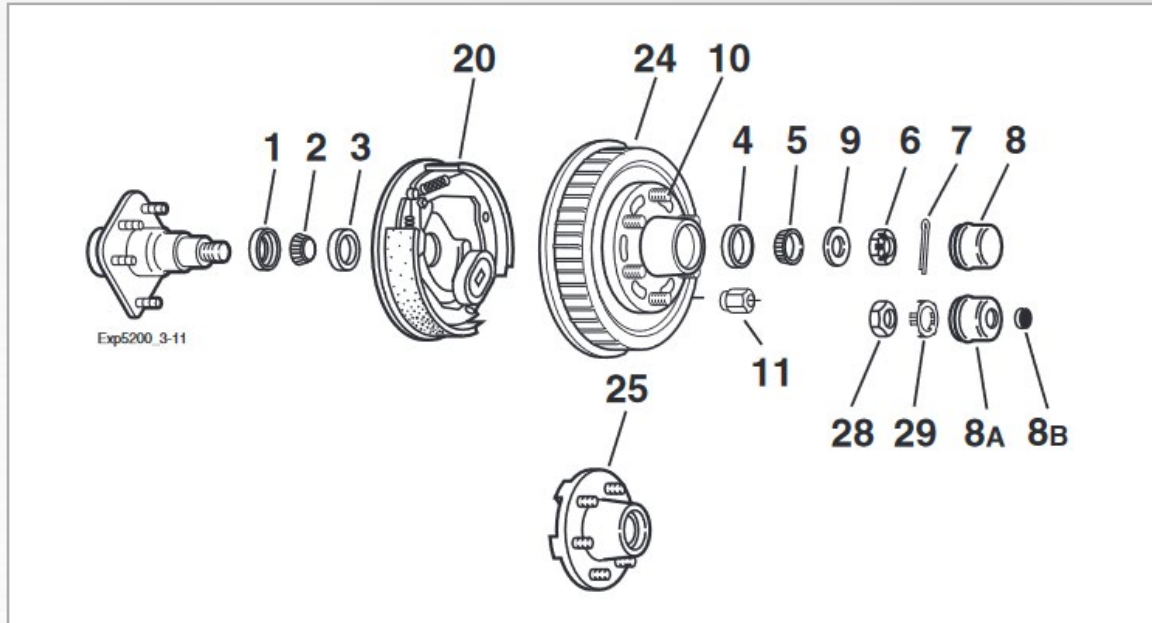

Grease Lube Parts

| Item | Part # | Description |
|------|----------|-------------------------------------------------|
| 1 | 10-54 | Grease Seal |
| 1 | 10-63 | Oil Seal |
| 2 | 25580 | Inner Bearing Cone |
| 3 | 25520 | Inner Bearing Cup |
| 4 | 15245 | Outer Bearing Cup |
| 5 | 15123 | Outer Bearing Cone |
| 6 | 6-176 | Spindle Nut |
| 7 | 19-2 | Cotter Pin (not used with E-Z Lube®) |
| 8 | 21-1 | Grease Cap |
| 8A | 21-42-1 | Grease Cap for E-Z Lube® |
| 8B | 85-1 | Rubber Plug for E-Z Lube® |
| 9 | 5-23 | Spindle Washer |
| 28 | 6-191-00 | Special Jam Nut for E-Z Lube® (after 2002) |
| 29 | 6-190-00 | Spindle Nut Retainer for E-Z Lube® (after 2002) |

Studs and Wheel Nuts

| Item | Part # | Description |
|------|--------|-------------------------------------------------------|
| 10 | 7-122 | ½-20 x 1.99 Long Press-in Stud* |
| 10 | 7-262 | ½-20 x 2.70 Long Press-in Stud* (hub-drum after 2/09) |
| 11 | 6-80 | ½-20 60° Cone Nut |

* Stud length measured under head to end of stud
 8 on 6.5 hubs are available on these axles.
 See 5500-7000 LBS capacity section

12" x 2" Brakes

| Item | Part # | Description |
|------|-----------------------|-----------------------------------------------|
| 20 | 23-105 / 23-106 | LH/RH Electric 6K CSA |
| NS | 23-112 / 23-113 | LH/RH Electric w/ park 6K CSA |
| ns | 23-324 / 23-325 | LH/RH Hydraulic Uni-Servo |
| ns | 23-320 / 23-321 | LH/RH Hydraulic Uni-servo w/park |
| ns | 23-322 / 23-323 | LH/RH Hydraulic Duo-servo |
| ns | 23-318 / 23-319 | LH/RH Hydraulic Duo-servo w/park |
| ns | 23-342 / 23-343 | LH/RH Hydraulic Free Backing |
| NS | 23-340 / 23-341 | LH/RH Hydraulic Free Backing w/ Park |
| NS | 23-342 / 23-343 | LH/RH Hydraulic FB Corrosion Resistant |
| ns | 23-340-01 / 23-341-01 | LH/RH Hydraulic FB Corrosion Resistant w/park |
| ns | 23-458 / 23-459 | LH/RH Electric Nev-R-Adjust® 6k CSA |

NS - not shown

Hubs

| Item | Part # | Description | Bolt Circle |
|-----------------------|---------|---------------------------------|-------------|
| Hubs and Drums | | | |
| 24 | 8-201-9 | ½" Stud 15123 bearing for 6000# | 6 on 5.50 |
| Plain Hubs | | | |
| 25 | 8-213-9 | ½" Stud 15123 bearing for 6000# | 6 on 5.50 |

5500 - 7000 LBS CAPACITY 865 and Demountable Hub Group

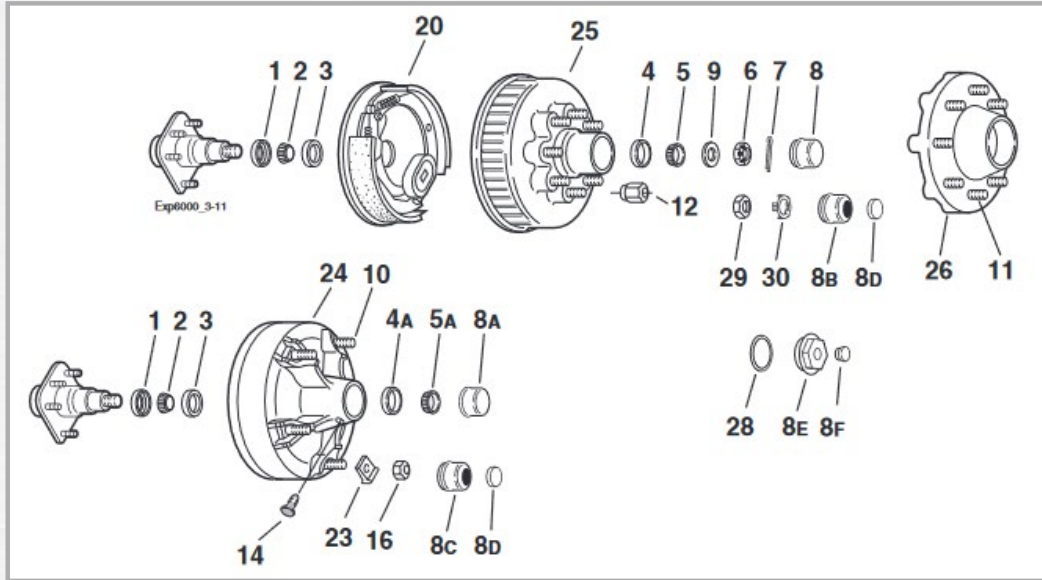

Grease Lube Parts

| Item | Part # | Description |
|------|----------|--------------------------------------------------|
| 1 | 10-54 | E-Z Lube® Seal 2.25" |
| 2 | 25580 | Inner Bearing Cone |
| 3 | 25520 | Inner Bearing Cup |
| 4 | 14276 | Outer Bearing Cup - 865 Hub |
| 5 | 14125A | Outer Bearing Cone - 865 Hub |
| 6 | 6-176 | Spindle Nut |
| 7 | 19-2 | Cotter Pin (not used with E-Z Lube®) |
| 8 | 21-39 | Grease Cap - 865 Hub |
| 8A | 21-1 | Grease Cap - Demountable |
| 8B | 21-43-1 | Grease Cap for E-Z Lube® - 865 Hub |
| 8B | 21-43-2 | Grease Cap for E-Z Lube® Chrome Option - 865 Hub |
| 8C | 21-42-1 | Grease Cap for E-Z Lube® - Demountable |
| 8C | 21-42-2 | Grease Cap for E-Z Lube® Chrome Option - Dem. |
| 8D | 85-1 | E-Z Lube® Rubber Plug |
| 9 | 5-57 | Spindle Washer |
| 16 | 6-5 | 5/16" - 18 Nut for Rim Clamp |
| 23 | 15-2 | Rim Clamp |
| 29 | 6-191-00 | Special Jam Nut for E-Z Lube® (after 2002) |
| 30 | 6-190-00 | Spindle Nut Retainer for E-Z Lube® (after 2002) |

Oil Lube Parts

| Item | Part # | Description |
|------|--------|---------------------------------------|
| 1 | 10-63 | Oil Seal 2.25" |
| 2 | 25580 | Inner Bearing Cone |
| 3 | 25520 | Inner Bearing Cup |
| 4 | 14276 | Outer Bearing Cup - 865 Hub |
| 4 | 15245 | Outer Bearing Cup - Demountable |
| 5 | 15123 | Outer Bearing Cone |
| 5 | 14125A | Outer Bearing Cone |
| 6 | 6-176 | Spindle Nut |
| 7 | 19-2 | Cotter Pin |
| 8E | 21-35 | Oil Cap - 865 Hub |
| ns | 21-4 | Oil Cap - Demountable |
| 8F | 46-32 | Oil Cap Plug |
| 9 | 5-57 | Spindle Washer |
| 14 | 46-52 | Oil Filler Plug - 865 and Demountable |
| ns | 46-32 | Oil Cap Plug |
| 16 | 6-5 | 5/16" - 18 Nut for Rim Clamp |
| 23 | 15-2 | Rim Clamp |
| 28 | 10-45 | 865 'O' Ring |
| ns | 10-59 | Demountable 'O' Ring |

ns -not shown
6 on 5.5 hubs are available on these axles.
See 4100-6000 LBS capacity section

Hubs

| Item | Part # | Description | Bolt Circle |
|-----------------------|----------|-------------------|-------------|
| Hubs and Drums | | | |
| 24 | 8-174-5 | Grease 5/16" Stud | Demountable |
| 24 | 8-174-6 | Oil 5/16" Stud | Demountable |
| 25 | 8-219-4 | Grease 1/2" Stud | 8 on 6.50 |
| 25 | 8-219-13 | Grease 5/16" Stud | 8 on 6.50 |
| 25 | 8-219-18 | Grease 5/8" Stud | 8 on 6.50 |
| 25 | 8-219-9 | Oil 1/2" Stud | 8 on 6.50 |
| 25 | 8-219-2 | Oil 5/16" Stud | 8 on 6.50 |
| 25 | 8-219-26 | Oil 5/8" Stud | 8 on 6.50 |
| Plain Hubs | | | |
| 26 | 8-231-9 | Grease 1/2" Stud | 8 on 6.50 |
| 26 | 8-231-18 | Grease 5/16" Stud | 8 on 6.50 |
| 26 | 8-231-2 | Grease 5/8" Stud | 8 on 6.50 |
| 26 | 8-231-16 | Oil 1/2" Stud | 8 on 6.50 |

Brakes

| Item | Part # | Description |
|------|---------------------|----------------------------------------|
| 20 | 23-105 / 23-106 | LH/RH Electric 6K CSA |
| ns | 23-112 / 23-113 | LH/RH Electric w/ park 6K CSA |
| ns | 23-180 / 23-181 | LH/RH Electric 7K |
| ns | 23-338 / 23-339 | LH/RH Hydraulic Uni-servo 7K |
| ns | 23-334 / 23-335 | LH/RH Hydraulic Uni-servo 7K w/park |
| ns | 23-336 / 23-337 | LH/RH Hydraulic Duo-servo 7K |
| ns | 23-332 / 23-333 | LH/RH Hydraulic Duo-servo 7K w/park |
| ns | 23-342 / 23-343 | LH/RH Hydraulic Uni-servo 7K FB |
| ns | 23-340 / 23-341 | LH/RH Hydraulic Uni-servo 7K FB w/park |
| ns | 23-342-1 / 23-343-1 | LH/RH Hydraulic Uni-servo 7K FB |
| ns | 23-340-1 / 23-341-1 | LH/RH Hydraulic Uni-servo 7K FB w/park |
| ns | 23-458 / 23-459 | LH/RH Electric Nev-R-Adjust® |

Studs and Wheel Nuts

| Item | Part # | Description |
|------|--------|----------------------------------------------------------|
| 10 | 25-11 | 5/16"-18 Stud - UTG |
| 11 | 7-122 | 1/2"-20 x 1.84 Long Press-in Stud* (hubs before 1/04) |
| 11 | 7-262 | 1/2"-20 x 2.70 Long Press-in Stud* (hubs after 1/04) |
| 12 | 6-80 | 1/2"-20 60° Cone Nut |
| ns | 7-132 | 5/16"-18 Press-in Stud |
| ns | 6-53 | 5/16"-18 60° Cone Nut |
| ns | 7-232 | 5/8"-18 Press-in Stud |
| ns | 6-109 | 5/8"-18 60° Cone Nut |
| ns | 6-58 | 5/8"-18 Flange Nut |

* Stud length measured under head to end of stud

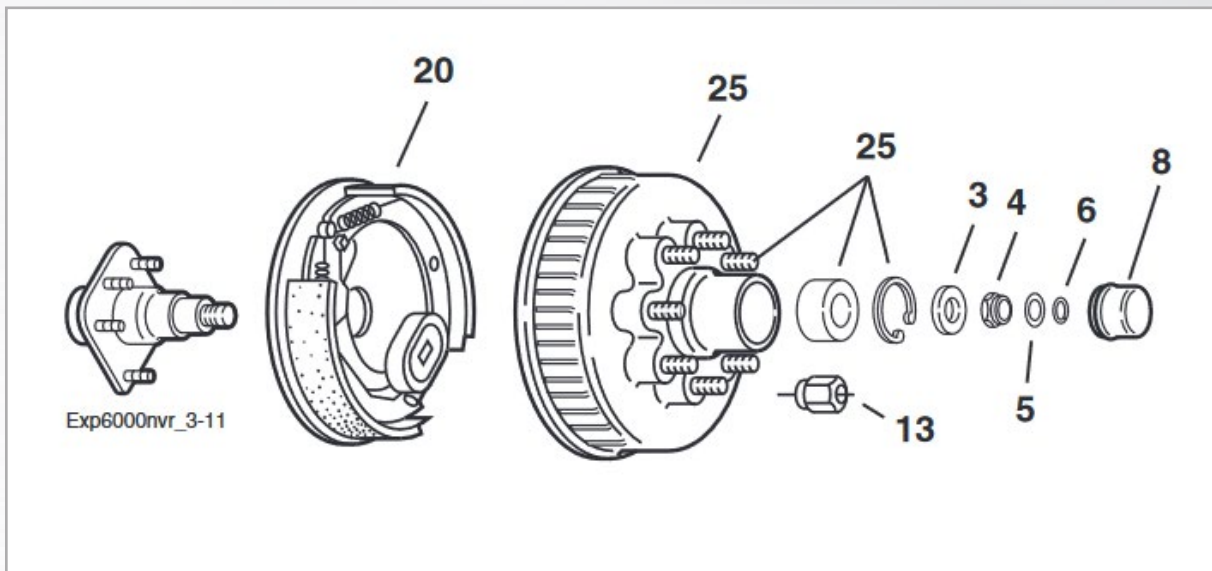

Nev-R-Lube® Parts

| Item | Part # | Description |
|------|---------|----------------------|
| ns | 5-147-1 | Spindle Washer, 42mm |
| 3 | 5-149 | Spindle Washer 50mm |
| 4 | 6-183 | Spindle Nut |
| 5 | 92-2 | Washer, Torque Label |
| 6 | 69-96 | Snap Ring |
| ns | 21-85 | Grease Cap, 42mm |
| 8 | 21-86 | Grease Cap, 50mm |

12" x 2" Brakes

| Item | Part # | Description |
|------|-----------------|----------------------------------------|
| 20 | 23-105 / 23-106 | LH/RH Electric 6K |
| ns | 23-180 / 23-181 | LH/RH Electric 7K |
| ns | 23-338 / 23-339 | LH/RH Hydraulic Uni-servo 7K |
| ns | 23-334 / 23-335 | LH/RH Hydraulic Uni-servo 7K w/park |
| ns | 23-336 / 23-337 | LH/RH Hydraulic Duo-servo 7K |
| ns | 23-332 / 23-333 | LH/RH Hydraulic Duo-servo 7K w/park |
| ns | 23-342 / 23-343 | LH/RH Hydraulic Free Backing 7K |
| ns | 23-340 / 23-341 | LH/RH Hydraulic 7K Free Backing w/park |
| ns | 23-326 / 23-327 | LH/RH Electric 6K CSA |
| ns | 23-458 / 23-459 | LH/RH Electric Nev-R-Adjust® |
| ns | 23-466 / 23-467 | LH/RH Electric Nev-R-Adjust® 6K CSA |

ns -not shown

Hubs with Bearing and Wheel Studs

| Item | Part # | Description | Bolt Circle |
|------|----------|--------------------------------------------------------------------------------------------------------------------|-------------|
| ns | 8-388-8 | Hub and Drum includes: 7-122 1/2-20 Press-in Studs 31-75-3 42mm Bearing Cartridge 69-95 Bearing Retainer | 6 on 5.50 |
| 25 | 8-385-82 | Hub and Drum includes: 7-122 1/2-20 Press-in Studs 31-71-3 50mm Bearing Cartridge 69-93 Bearing Retainer | 8 on 6.50 |
| ns | 8-385-81 | Hub and Drum includes: 7-223 5/16-18 Press-in Studs 31-71-3 50mm Bearing Cartridge 69-93 Bearing Retainer | 8 on 6.50 |
| ns | 8-385-8 | Hub and Drum includes: 7-224 5/16-18 Press-in Studs 31-71-3 50mm Bearing Cartridge 69-93 Bearing Retainer | 8 on 6.50 |

Studs and Wheel Nuts

| Item | Part # | Description |
|------|--------|----------------------|
| 13 | 6-80 | 1/2-20 60° Cone Nut |
| ns | 6-53 | 5/16-18 60° Cone Nut |
| ns | 6-109 | 5/16-18 90° Cone Nut |
| ns | 6-58 | 5/16-18 Flange Nut |

7200 LBS CAPACITY 865 Hub Group

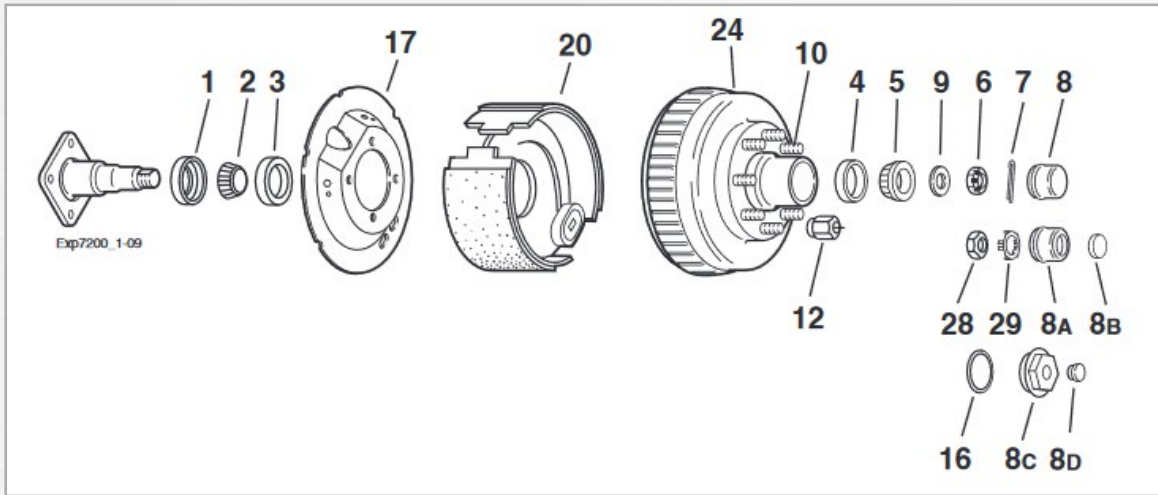

Grease Lube Parts

| Item | Part # | Description |
|------|----------|-------------------------------------------------|
| 1 | 10-36 | Seal |
| 2 | 25580 | Inner Bearing Cone |
| 3 | 25520 | Inner Bearing Cup |
| 4 | 2420 | Outer Bearing Cup |
| 5 | 2475 | Outer Bearing Cone |
| 6 | 6-176 | Spindle Nut |
| 7 | 19-2 | Cotter Pin (not used with E-Z Lube®) |
| 8 | 21-39 | Grease Cap |
| 8A | 21-1 | Grease Cap for E-Z Lube® |
| 8B | 85-1 | E-Z Lube® Rubber Plug |
| 9 | 5-57 | Spindle Washer |
| 28 | 6-191-00 | Special Jam Nut for E-Z Lube® (after 2002) |
| 29 | 6-190-00 | Spindle Nut Retainer for E-Z Lube® (after 2002) |

Oil Lube Parts

| Item | Part # | Description |
|------|--------|-------------------------------------|
| 1 | 10-63 | Seal (Unitized) |
| 2 | 25580 | Inner Bearing Cone |
| 3 | 25520 | Inner Bearing Cup |
| 4 | 2420 | Outer Bearing Cup |
| 5 | 2475 | Outer Bearing Cone |
| 6 | 6-176 | Spindle Nut |
| 7 | 19-2 | Cotter Pin |
| 9 | 5-57 | Spindle Washer |
| 8C | 21-35 | OilCap |
| 8D | 46-32 | Oil Cap Plug |
| ns | 46-52 | Oil Filler Plug (service part only) |
| 16 | 10-45 | 'O' Ring for Oil Lube |

Studs and Wheel Nuts

| Item | Part # | Description |
|------|--------|--------------------|
| 10 | 7-122 | ½-20 Press-in Stud |
| 10 | 7-224 | ⅝-18 Press-in Stud |
| 10 | 7-223 | ⅞-18 Press-in Stud |
| 12 | 6-53 | ⅞-18 60° Cone Nut |
| 12 | 6-109 | ⅞-18 90° Cone Nut |
| ns | 6-58 | ⅞-18 Flange Nut |

Hubs

(After May 2000 for cast backing plate brakes)

| Item | Part # | Description | Bolt Circle |
|------|---------|----------------|-------------|
| 24 | 8-393-1 | Grease ½" Stud | 8 on 6.50 |
| 24 | 8-393-4 | Grease ⅜" Stud | 8 on 6.50 |
| 24 | 8-393-6 | Grease ⅝" Stud | 8 on 6.50 |
| 24 | 8-393-9 | Oil ½" Stud | 8 on 6.50 |
| 24 | 8-393-3 | Oil ⅜" Stud | 8 on 6.50 |
| 24 | 8-393-5 | Oil ⅝" Stud | 8 on 6.50 |

Brakes

(After May 2000 for cast backing plate brakes)

| Item | Part # | Description |
|------|----------|----------------------------------------------|
| 17 | 36-118-2 | Dust shield not included with brake assembly |
| 20 | 23-429 | RH 12 ¼" x 2 ½" Electric Brakes |
| 20 | 23-428 | LH 12 ¼" x 2 ½" Electric Brakes |

Service parts NOT interchangeable with Cast Parts

Hubs

(Before May 2000 for stamped backing plate brakes)

| Item | Part # | Description | Bolt Circle |
|------|----------|----------------|-------------|
| 24 | 8-355-13 | Grease ⅜" Stud | 8 on 6.50 |
| 24 | 8-355-15 | Grease ⅝" Stud | 8 on 6.50 |
| 24 | 8-355-12 | Oil ⅜" Stud | 8 on 6.50 |
| 24 | 8-355-14 | Oil ⅝" Stud | 8 on 6.50 |

Brakes

(Before May 2000 with stamped backing plate brakes)

| Item | Part # | Description |
|------|----------|---------------------------------------------------|
| 17 | 36-110 | Dust shield (top) included with brake assembly |
| 17 | 36-110-1 | Dust shield (bottom) included with brake assembly |
| 20 | 23-369 | RH 12 ¼" x 2 ½" Electric Brakes |
| 20 | 23-370 | LH 12 ¼" x 2 ½" Electric Brakes |

ns -not shown

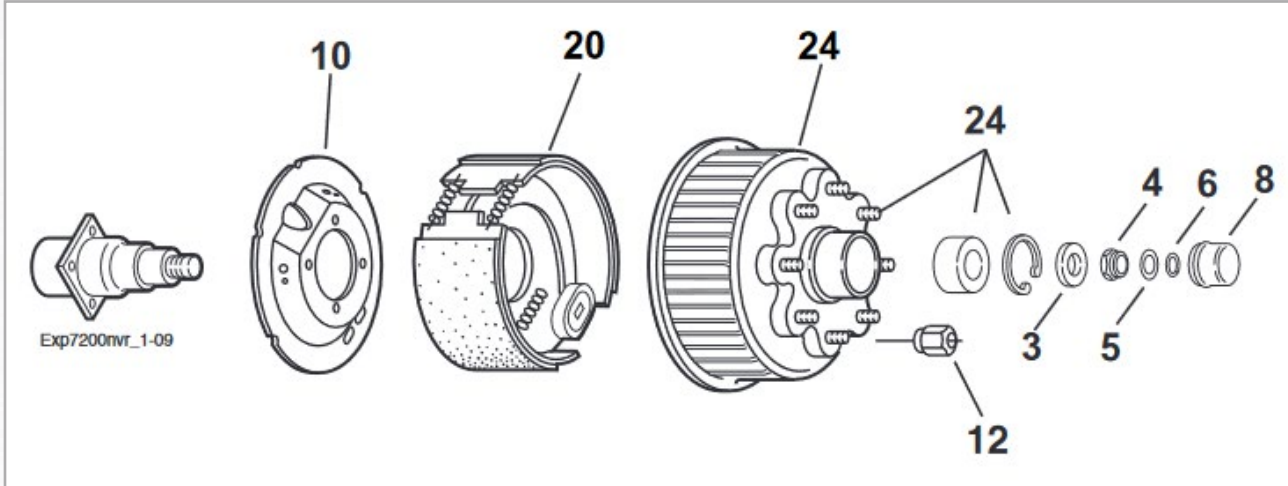

Nev-R-Lube® Parts

| Item | Part # | Description |
|------|--------|----------------------|
| 3 | 5-149 | Spindle Washer |
| 4 | 6-183 | Spindle Nut |
| 5 | 92-2 | Washer, Torque Label |
| 6 | 69-96 | Snap Ring |
| 8 | 21-86 | Grease Cap, 50mm |

12 1/4" x 2 1/2" Brakes

| Item | Part # | Description |
|------|-----------------|------------------------------------|
| 10 | 36-118-2 | Dust Shield |
| 20 | 23-428 / 23-429 | LH/RH Manual Adjust Electric Brake |

Hubs with Bearing and Wheel Studs

| Item | Part # | Description | Bolt Circle |
|------|----------|------------------------------------------------------------------------------------------------------------------|-------------|
| 24 | 8-395-8 | Hub and Drum includes: 7-223 5/16" Press-in Studs 31-71-3 50mm Bearing Cartridge 69-93 Bearing Retainer | 8 on 6.50 |
| ns | 8-395-81 | Hub and Drum includes: 7-224 5/8" Press-in Studs 31-71-3 50mm Bearing Cartridge 69-93 Bearing Retainer | 8 on 6.50 |

Studs and Wheel Nuts

| Item | Part # | Description |
|------|--------|-----------------------|
| 12 | 6-53 | 5/16"-18 60° Cone Nut |
| ns | 6-109 | 5/8"-18 90° Cone Nut |
| ns | 6-58 | 5/8"-18 Flange Nut |

ns -not shown

8000 LBS CAPACITY 865 Hub Group

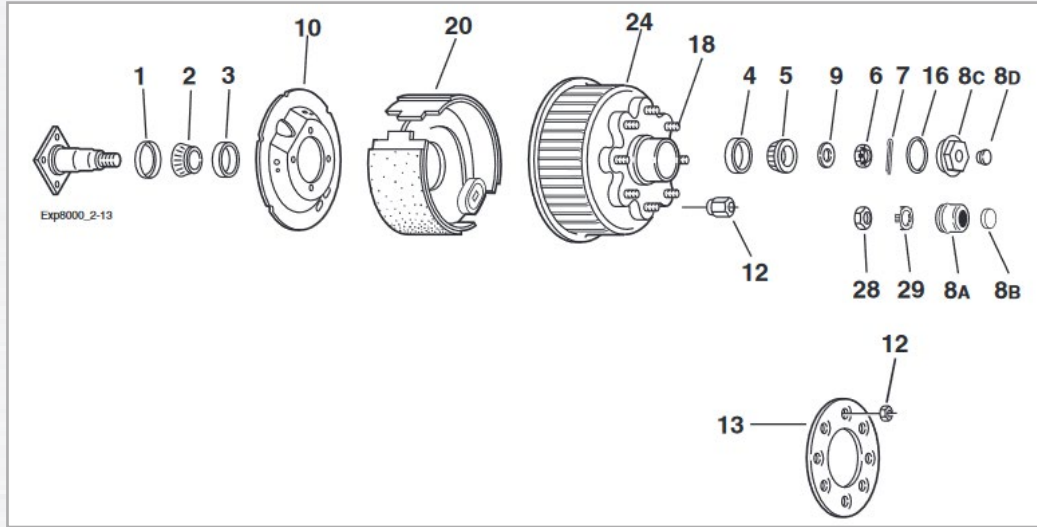

Grease Lube Parts

| Item | Part # | Description |
|------|----------|-------------------------------------------------|
| 1 | 10-54 | E-Z Lube® Seal 2.25" |
| 2 | 25580 | Inner Bearing Cone |
| 3 | 25520 | Inner Bearing Cup |
| 4 | 2420 | Outer Bearing Cup |
| 5 | 2475 | Outer Bearing Cone |
| 6 | 6-176 | Spindle Nut |
| 7 | 19-2 | Cotter Pin (not used with E-Z Lube®) |
| ns | 21-39 | Grease Cap |
| 8A | 21-43-1 | Grease Cap for E-Z Lube® |
| 8B | 85-1 | E-Z Lube® Rubber Plug |
| 9 | 5-57 | Spindle Washer |
| 28 | 6-191-00 | Special Jam Nut for E-Z Lube® (after 2002) |
| 29 | 6-190-00 | Spindle Nut Retainer for E-Z Lube® (after 2002) |

Oil Lube Parts

| Item | Part # | Description |
|------|--------|-------------------------------------|
| 1 | 10-63 | Seal (Unitized) |
| 2 | 25580 | Inner Bearing Cone |
| 3 | 25520 | Inner Bearing Cup |
| 4 | 2420 | Outer Bearing Cup |
| 5 | 2475 | Outer Bearing Cone |
| 6 | 6-176 | Spindle Nut |
| 7 | 19-2 | Cotter Pin |
| 8C | 21-35 | Oil Cap |
| 8D | 46-32 | Oil Cap Plug |
| 9 | 5-57 | Spindle Washer |
| ns | 46-52 | Oil Filler Plug (service part only) |
| 16 | 10-45 | 'O' Ring for Oil Lube |

ABS Components

| Part # | Description |
|---------|------------------------|
| 97-4 | Sensor, Straight |
| 21-24 | Sensor Block, Screw-in |
| 97-2 | Sensor retainer Clip |
| 24-25-1 | Sensor Tone Ring |

12 1/4" x 3 3/8" Brakes

| Item | Part # | Description |
|------|-----------------|----------------------------------------|
| 10 | 36-115-2 | Dust Shield |
| 10 | 36-115-24 | Dust Shield for brakes with park |
| 20 | 23-434 / 23-435 | LH/RH Electric Self-Adjust |
| ns | 23-432 / 23-433 | LH/RH Electric Manual Adjust |
| ns | 23-402 / 23-403 | LH/RH Hydraulic Self-Adjust Duo-Servo |
| ns | 23-171 / 23-172 | LH/RH Hyd. Self-Adj Duo-Servo w/park |
| ns | 23-418 / 23-419 | LH/RH Hydraulic Uni-Servo |
| ns | 23-252 / 23-253 | LH/RH Hydraulic Uni-Servo w/park |
| ns | 23-420 / 23-421 | LH/RH Self Adj. DS Corrosion Resistant |
| ns | 23-388 / 23-387 | LH/RH Hyd. Manual Adjust Duo-Servo |

Hubs

| Item | Part # | Description | Bolt Circle |
|-----------------------|----------|----------------------|-------------|
| Hubs and Drums | | | |
| 24 | 8-285-8 | Grease 5/8" Stud | 8 on 6.50 |
| 24 | 8-285-15 | Grease 5/8" Stud ABS | 8 on 6.50 |
| 24 | 8-285-11 | Grease 3/8" Stud | 8 on 6.50 |
| 24 | 8-285-13 | Grease 3/8" Stud ABS | 8 on 6.50 |
| 24 | 8-285-1 | Oil 5/8" Stud | 8 on 6.50 |
| 24 | 8-285-14 | Oil 5/8" Stud ABS | 8 on 6.50 |
| 24 | 8-285-9 | Oil 3/8" Stud | 8 on 6.50 |
| 24 | 8-285-12 | Oil 3/8" Stud ABS | 8 on 6.50 |
| Plain Hubs | | | |
| ns | 8-287-7 | Grease 5/8" Stud | 8 on 6.50 |
| ns | 8-287-11 | Grease 3/8" Stud | 8 on 6.50 |
| ns | 8-287-17 | Oil 5/8" Stud | 8 on 6.50 |
| ns | 8-287-14 | Oil 3/8" Stud | 8 on 6.50 |

Studs and Wheel Nuts

| Item | Part # | Description |
|------|---------|----------------------------------|
| 12 | 6-53 | 5/16-18 60° Cone Nut |
| 12* | 6-109 | 5/8-18 90° Cone Nut (200 lbs-ft) |
| 13* | 33-52-1 | Clamp Ring |
| 18 | 7-132 | 5/16-18 Press-in Stud |
| 18 | 7-232 | 5/8-18 Press-in Stud |
| ns | 6-58 | 5/8-18 Flange Nut |

ns -not shown

* Must use the 90° cone nut with the clamp ring. Alternate fastener is just the flange nut.

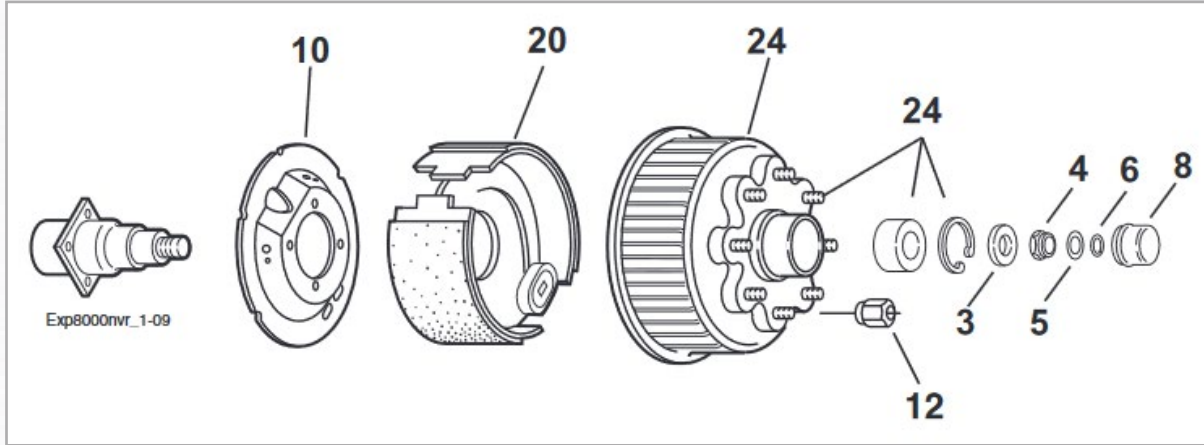

Nev-R-Lube® Parts

| Item | Part # | Description |
|------|--------|----------------------|
| 3 | 5-149 | Spindle Washer |
| 4 | 6-183 | Spindle Nut |
| 5 | 92-2 | Washer, Torque Label |
| 6 | 69-96 | Snap Ring |
| 8 | 21-86 | Grease Cap, 50mm |

12 1/4" x 3 3/8" Brakes

| Item | Part # | Description |
|------|-----------------|---------------------------------------|
| 10 | 36-118-2 | Dust Shield |
| 10 | 35-115-24 | Dust shield for brakes with park |
| 20 | 23-434 / 23-435 | LH/RH Electric Self-Adjust |
| ns | 23-402 / 23-403 | LH/RH Hydraulic Self-Adjust Duo-Servo |
| ns | 23-171 / 23-172 | LH/RH Hyd. Self-Adj Duo-Servo w/park |
| ns | 23-418 / 23-419 | LH/RH Hydraulic Uni-Servo |
| ns | 23-252 / 23-253 | LH/RH Hydraulic Uni-Servo w/park |

ABS Hubs without Bearing

| Item | Part # | Description | Bolt Circle |
|------|----------|-----------------------|-------------|
| 24 | 8-389-9 | Grease 5/16" Stud ABS | 8 on 6.50 |
| 24 | 8-389-12 | Grease 9/16" Stud ABS | 8 on 6.50 |

Hubs with Bearing and Wheel Studs

| Item | Part # | Description | Bolt Circle |
|------|----------|-----------------------------------------------------------------------------------------------------------------|-------------|
| 24 | 8-389-81 | Hub and Drum includes: 7-223 1/8" Press-in Studs 31-71-3 50mm Bearing Cartridge 69-93 Bearing Retainer | 8 on 6.50 |
| ns | 8-389-8 | Hub and Drum includes: 7-224 3/8" Press-in Studs 31-71-3 50mm Bearing Cartridge 69-93 Bearing Retainer | 8 on 6.50 |

Wheel Nuts

| Item | Part # | Description |
|------|--------|-----------------------|
| 12 | 6-53 | 9/16"-18 60° Cone Nut |
| ns | 6-109 | 5/8"-18 90° Cone Nut |

ABS Components

| Part # | Description |
|--------|------------------------|
| 97-4 | Sensor, Straight |
| 24-204 | Sensor Block, Screw-in |
| 97-2 | Sensor Retainer Clip |

ns -not shown

9,000-10,000 LBS GD CAPACITY

9K, 10K and #13G General Duty Two-Piece Hubs

After July 2009

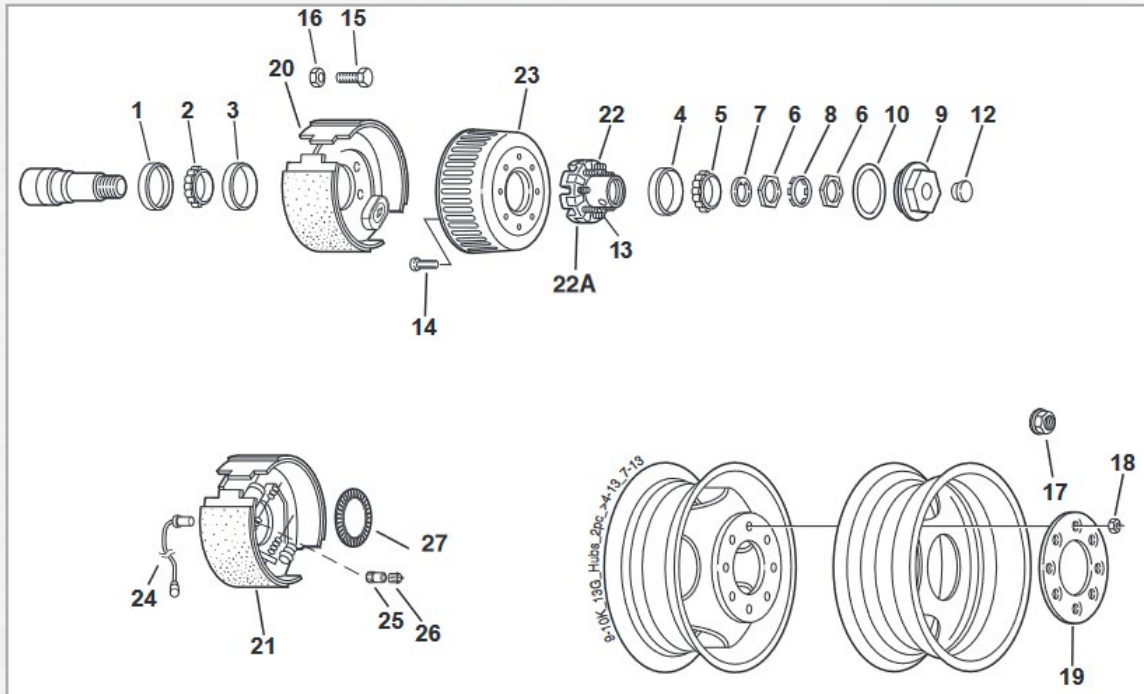

Standard Oil Lube Parts

| Item | Part # | Description |
|------|---------|---------------------|
| 1 | 10-51-1 | Oil Seal |
| 2 | 387A | Inner Bearing Cone |
| 3 | 382A | Inner Bearing Cup |
| 4 | 25520 | Outer Bearing Cup |
| 5 | 25580 | Outer Bearing Cone |
| 6 | 6-96 | Spindle Nut (2) |
| 7 | 5-70 | Spindle Washer |
| 8 | 5-71 | Tang Washer |
| 9 | 21-88 | Oil Cap |
| 10 | 10-163 | 'O' Ring |
| 12 | 46-32 | Oil Cap Plug |
| 13 | 7-115 | 5/8-18 Wheel Stud |
| 14 | 7-292 | Drum Mounting Screw |

Hub and Drum

| Item | Part # | Description |
|------|---------|---------------------------------------|
| ns | 8-430-5 | Oil Hub and Drum w/Cups and Studs |
| 22 | 8-430-3 | Oil Hub w/Cups and Studs |
| 23 | 9-123-1 | Drum - Machined |
| ns | 8-430-7 | Oil Hub and Drum w/Cups and Studs ABS |
| 22 | 8-430-3 | Oil Hub w/Cups and Studs |
| ns | 9-123-3 | Drum - for ABS |

12 1/4" x 3 3/8" Brakes

| Item | Part # | Description |
|------|-----------------|-----------------------------------------------------|
| 20 | 23-450 / 23-451 | LH/RH Electric, FSA |
| 21 | 23-410 / 23-411 | LH/RH Hydraulic, FSA, Duo-Servo |
| 21 | 23-210 / 23-211 | LH/RH Hydraulic, RSA, Duo-Servo w/park |
| ns | 23-412 / 23-413 | LH/RH Hydraulic, FSA, Single-Servo |
| ns | 23-234 / 23-235 | LH/RH Hydraulic, Manual Adjust, Single-Servo w/park |

ABS Components

| Item | Part # | Description |
|------|----------|------------------------|
| 24 | 97-4 | Sensor, Straight |
| 25 | 24-204 | Sensor Block, Screw-in |
| 26 | 97-2 | Sensor Clip |
| 27 | 24-205-1 | Tone Ring |
| ns | 7-248 | Tone Ring Screws |

Studs and Wheel Nuts

| Item | Part # | Description |
|------|---------|-----------------------------------|
| 18* | 6-109 | 5/8-18 90° Cone Nut (200 lbs.-ft) |
| 19* | 33-52-1 | Clamp Ring |
| 17 | 6-58 | 5/8-18 Flange Nut (300 lbs.-ft) |
| 13 | 7-115 | 5/8-18 Press-in Stud |

ns -not shown

* Must use the 90° cone nut with the clamp ring. Alternate fastener is just the flange nut.

9,000-10,000 LBS GD CAPACITY

9K, 10K, #13G, #14T General Duty Two-Piece Hubs

Before July 2009

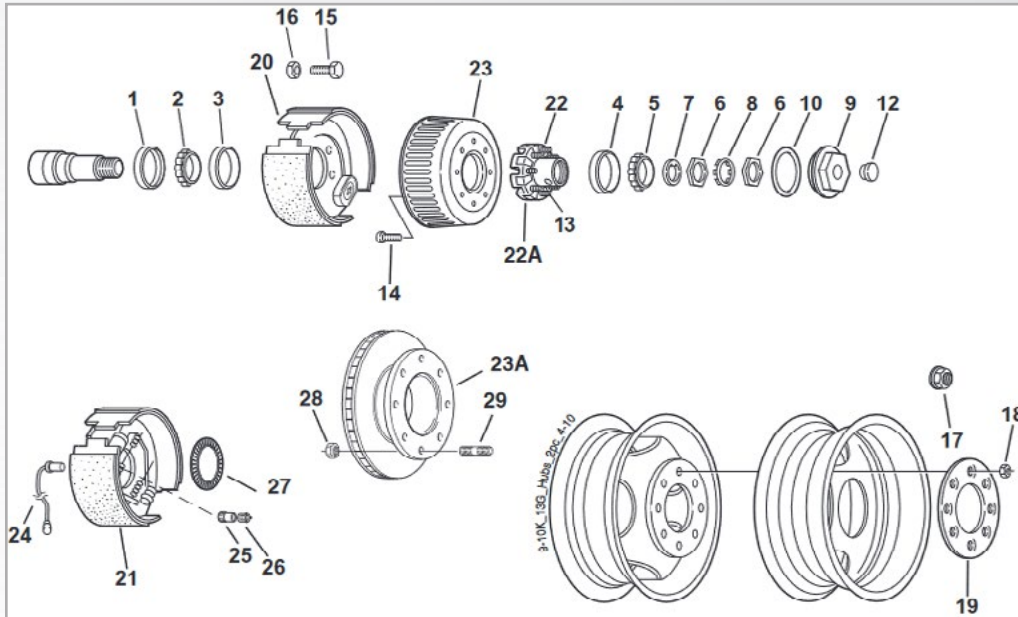

Standard Oil Lube Parts

| Item | Part # | Description |
|------|---------|---------------------|
| 1 | 10-51-1 | Oil Seal |
| 2 | 387A | Inner Bearing Cone |
| 3 | 382A | Inner Bearing Cup |
| 4 | 25520 | Outer Bearing Cup |
| 5 | 25580 | Outer Bearing Cone |
| 6 | 6-96 | Spindle Nut (2) |
| 7 | 5-70 | Spindle Washer |
| 8 | 5-71 | Tang Washer |
| 9 | 21-36 | Oil Cap |
| 10 | 10-50 | 'O' Ring |
| 12 | 46-32 | Oil Cap Plug |
| 13 | 7-115 | 5/8-18 Wheel Stud |
| 14 | 7-245 | Drum Mounting Screw |
| 15 | 7-116 | Brake Mounting Bolt |
| 16 | 6-17 | Brake Mounting Nut |
| ns | 5-08 | Lockwasher |

Hub and Drum

| Item | Part # | Description |
|------|---------|-----------------------------------|
| 22 | 8-288-3 | Oil Hub w/Cups and Studs |
| 23 | 9-44-1 | Drum - Machined |
| ns | 9-44-3 | Drum - for ABS |
| ns | 8-288-5 | Oil Hub and Drum w/Cups and Studs |

Hub and Rotor Available on #13G Not offered on D90, D100G, #14T

| Item | Part # | Description |
|------|----------|--------------------------|
| 22A | 8-288-7 | Oil Hub w/Cups and Studs |
| 23A | 70-006-1 | Brake Rotor |
| 28 | 6-46 | Rotor Mounting Nut |
| 29 | 25-14 | Rotor Mounting Stud |

12 1/4" x 3 3/8" Brakes

| Item | Part # | Description |
|------|-----------------|-----------------------------------------------------|
| 20 | 23-450 / 23-451 | LH/RH Electric, FSA |
| 21 | 23-410 / 23-411 | LH/RH Hydraulic, FSA, Duo-Servo |
| 21 | 23-210 / 23-211 | LH/RH Hydraulic, RSA, Duo-Servo w/park |
| ns | 23-412 / 23-413 | LH/RH Hydraulic, FSA, Single-Servo |
| ns | 23-234 / 23-235 | LH/RH Hydraulic, Manual Adjust, Single-Servo w/park |

ABS Components

| Item | Part # | Description |
|------|--------|------------------------|
| 24 | 97-4 | Sensor, Straight |
| 25 | 24-204 | Sensor Block, Screw-in |
| 26 | 97-2 | Sensor Clip |
| 27 | 24-203 | Tone Ring |

Studs and Wheel Nuts

| Item | Part # | Description |
|------|---------|-----------------------------------|
| 18* | 6-109 | 5/8-18 90° Cone Nut (200 lbs.-ft) |
| 19* | 33-52-1 | Clamp Ring |
| 17 | 6-58 | 5/8-18 Flange Nut (300 lbs.-ft) |
| 13 | 7-115 | 5/8-18 Press-in Stud |

ns -not shown

* Must use the 90° cone nut with the clamp ring. Alternate fastener is just the flange nut.

One-piece hub/drum is not interchangeable with the two-piece hub/drum.

10,000-15,000 LBS CAPACITY

10K HD, 12K, 15K, #13D and #14 Hubs

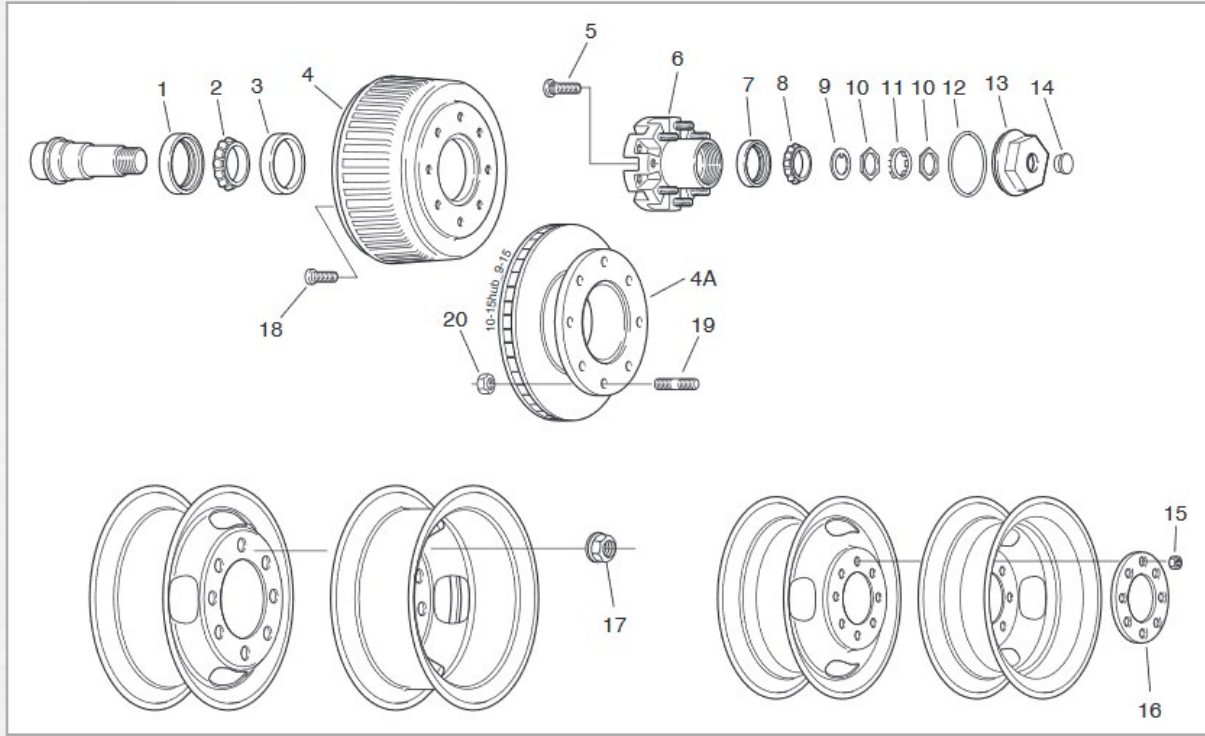

HUBS AND COMPONENTS

| Item | Description | 10K, #13D 8 on 6.50 | 10K, #13D Disc 8 on 6.50 | 12K Low-Profile 8 on 6.50 | 12K Hi-Profile 8 on 6.50 | #14 Hi Profile 8 on 6.50 | #14 Disc 8 on 6.50 | 12K Disc 8 on 6.50 | 15K 8 on 275mm |
|------|--------------------------|------------------------|--------------------------------|---------------------------------|--------------------------------|--------------------------------|--------------------------|--------------------------|-------------------------------------------|
| 1 | Unitized Oil Seal | 10-56 | 10-56 | 10-56 | 10-56 | 10-56 | 10-56 | 10-56 | 10-56 |
| 2 | Inner Bearing Cone | 395S | 395S | 3984 | 3984 | 3984 | 3984 | 3984 | 39590 |
| 3 | Inner Bearing Cup | 394A | 394A | 3920 | 3920 | 3920 | 3920 | 3920 | 39590 |
| 4 | Brake Drum | 9-27-1 | - | 9-28-1 | 9-28-1 | 9-28-1 | - | - | 9-28-1 |
| 4 | Brake Drum - ABS | 9-27-3 | - | 9-28-5 | 9-28-5 | 9-28-5 | - | - | 9-28-5 |
| 4A | Brake Rotor | - | 70-6-1 | - | - | - | 70-10-2 | 70-6-1 | - |
| 4A | Brake Rotor - ABS | - | 70-6-2 | - | - | - | - | 70-6-2 | - |
| 5 | Wheel Mounting Stud | 7-115 | 7-115 | 7-115 | 7-115 | 7-115 | 7-115 | 7-115 | 7-194 (std) 7-195 (long) |
| 6 | Hubs w/ Cups & Studs | 8-214-5 | 8-214-6 | 8-216-8 | 8-214-8 | 8-422-3 | 8-422-4 | 8-214-1 | 8-401-5 (std stud) 8-401-6 (long stud) |
| 7 | Outer Bearing Cup | 382A | 382A | 28622 | 28622 | 28622 | 28622 | 28622 | 28622 |
| 8 | Outer Bearing Cone | 387A | 387A | 28682 | 28682 | 28682 | 28682 | 28682 | 28682 |
| 9 | Spindle Washer | 5-60 | 5-60 | 5-60 | 5-60 | 5-60 | 5-60 | 5-60 | 5-60 |
| 10 | Spindle Nut | 6-84 | 6-84 | 6-84 | 6-84 | 6-84 | 6-84 | 6-84 | 6-84 |
| 11 | Tang Washer | 5-59 | 5-59 | 5-59 | 5-59 | 5-59 | 5-59 | 5-59 | 5-59 |
| 12 | Oil Cap "O" Ring | 10-50 | 10-50 | 10-50 | 10-50 | 10-50 | 10-50 | 10-50 | 10-50 |
| 13 | Oil Cap | 21-36 | 21-36 | 21-36 | 21-36 | 21-36 | 21-36 | 21-36 | 21-36 |
| 14 | Oil Cap Plug | 46-32 | 46-32 | 46-32 | 46-32 | 46-32 | 46-32 | 46-32 | 46-32 |
| 15 | Wheel Nut | 6-109 | 6-109 | 6-109 | 6-109 | 6-109 | 6-109 | 6-109 | - |
| 16 | Wheel Clamp Ring | 33-52-1 | 33-52-1 | 33-52-1 | 33-52-1 | 33-52-1 | 33-52-1 | 33-52-1 | - |
| 17 | Flange Nut (swivel) | 6-209 | 6-209 | 6-209 | 6-209 | 6-209 | - | 6-209 | 6-118 |
| 18 | Drum Mounting Screw | 7-244 | - | 7-244 | 7-244 | 7-245 | - | - | 7-244 |
| 19 | Rotor Mounting Stud | - | 25-14 | - | - | - | - | 25-14 | - |
| 20 | Rotor Mounting Nut | - | 6-46 | - | - | - | - | 6-46 | - |
| 21 | Disc Mounting Screw (ns) | - | - | - | - | - | 7-292 | - | - |

ns -not shown



Hubs & Drums 12 1/4" x 7 1/2" Brake Size 10 Stud on 8 3/4" Hubs with Inboard Drums

For use with 15" or 17.5" ball seat mounted steel disc wheels

C

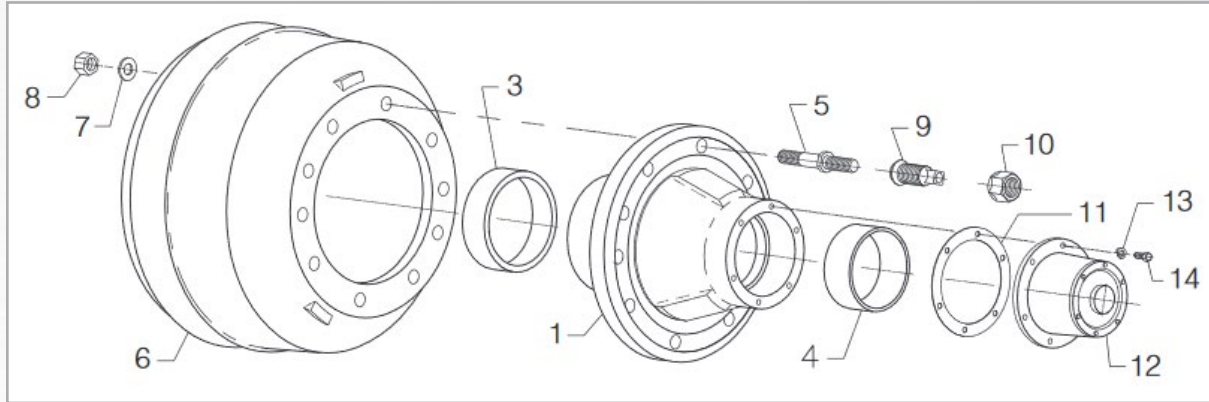

| Item | Part Number | Qty per Axle | Description | Comments |
|------|-------------|--------------|----------------------------------------------|---------------------------------|
| 0 | 8-277-71 | 1 | LH Assembly Hub & Drum 10 Stud 8 3/4" BC | Use Ball Seat Mtg. Steel Wheels |
| 0 | 8-277-7 | 1 | RH Assembly Hub & Drum 10 Stud 8 3/4" BC | Use Ball Seat Mtg. Steel Wheels |
| ns | 8-277-29 | 1 | LH Assembly Hub & Drum 10 Stud 8 3/4" BC ABS | Use Ball Seat Mtg. Steel Wheels |
| ns | 8-277-28 | 1 | RH Assembly Hub & Drum 10 Stud 8 3/4" BC ABS | Use Ball Seat Mtg. Steel Wheels |
| 1 | 8-277-4 | 1 | LH Assembly Hub 10 Stud 8 3/4" BC | Includes items 3-5 |
| 1 | 8-277-5 | 1 | RH Assembly Hub 10 Stud 8 3/4" BC | Includes items 3-5 |
| ns | 8-277-23 | 1 | LH Assembly Hub 10 Stud 8 3/4" BC ABS | Includes items 3-5 |
| ns | 8-277-22 | 1 | RH Assembly Hub 10 Stud 8 3/4" BC ABS | Includes items 3-5 |
| ns | 24-2-1 | 1 | ABS Tone Ring | Included with ABS Hubs |
| 3 | 31-26-1 | 1 | Inner Bearing Cup (HM218210) | |
| 4 | 31-27-1 | 1 | Outer Bearing Cup (HM212011) | |
| 5 | 25-56-2 | 10 | LH Shoulder Stud | |
| 5 | 25-56-1 | 10 | RH Shoulder Stud | |
| 6 | 9-40-1 | 1 | Drum 12 1/4" x 7 1/2" | |
| 7 | 5-102 | 10 | Washer | |
| 8 | 6-47 | 10 | Hex Nut - Drum Mounting | |
| 9 | 6-69-2 | 10 | LH Inner Cap Nut | For Steel Disc Wheels |
| 9 | 6-69-1 | 10 | RH Inner Cap Nut | For Steel Disc Wheels |
| 10 | 6-70-2 | 10 | LH Outer Cap Nut | |
| 10 | 6-70-1 | 10 | RH Outer Cap Nut | |
| 11 | 71-124 | 1 | Gasket - Oil Cap | |
| 12 | 21-38-2 | 1 | Oil Cap (with vent plug) | |
| 13 | 5-100 | 6 | Lock Washer - Oil Cap | |

HUBS AND COMPONENTS

Hub & Drum Dimensional Information

| Item | Description | Dimensions |
|----------------------------------------------------|----------------------|--------------------------|
| A | Cup to Cup | 3.34" |
| B | Cup to Mounting Face | .81" |
| C | Cup to End of Drum | 10.57" |
| D | Brake Diameter | 12.25" |
| E | Shoe Brake Width | 7.50" |
| F | Drum Overall Width | 10.50" |
| G | Pilot Diameter | 7.12" |
| H | Bolt Circle | 8.75" |
| I | Bolt Diameter | 3/4" |
| J | Hub Cap Hole Mtg. | 5/16" 6 Holes 5.50 BC |
| Inner Bearing Cup and Cone Overall Stack Thickness | | 1.575" |

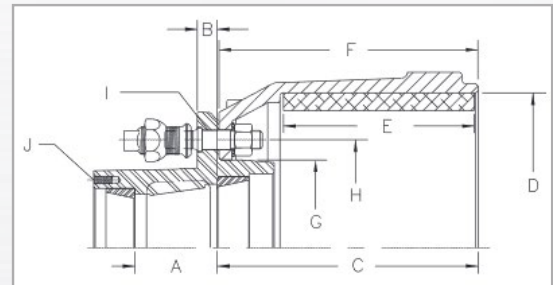

Hubs & Drums 12 1/4" x 7 1/2" Brake Size 8 Stud on 275mm (10.827") Hubs with Outboard Drums

For use with 17.5" or 19.5" 221mm piloted disc wheels

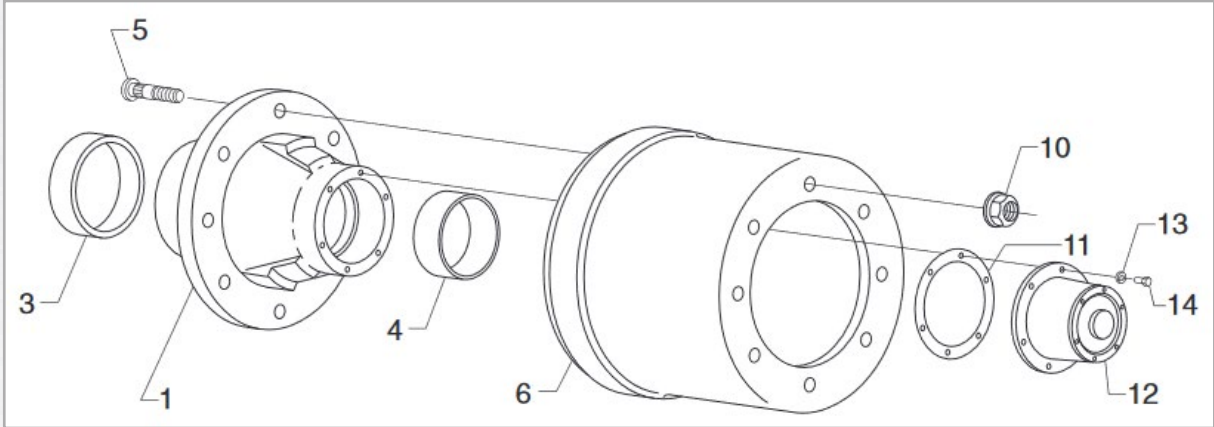

| Item | Part Number | Qty per Axle | Description | Comments |
|----------------|-------------|--------------|--------------------------------------------|----------------------------------------|
| 0 | 8-396-7 | 1 | Hub & Drum 8 Stud on 275mm BC Assembly | Use Pilot Mtg. Steel Wheels |
| ns | 8-396-72 | 1 | Hub & Drum 8 Stud on 275mm BC Assembly | Use Pilot Mtg. Aluminum Wheels |
| ns | 8-396-71 | 1 | Hub & Drum 8 Stud on 275mm BC Assembly ABS | Use Pilot Mtg. Steel Wheels |
| ns | 8-396-73 | 1 | Hub & Drum 8 Stud on 275mm BC Assembly ABS | Use Pilot Mtg. Aluminum Wheels |
| 1 | 8-396-5 | 1 | Hub 8 Stud on 275mm BC Assembly | Includes items 3-5 for Steel Wheels |
| ns | 8-396-6 | 1 | Hub 8 Stud on 275mm BC Assembly | Includes items 3-5 for Aluminum Wheels |
| ns | 8-396-7 | 1 | Hub 8 Stud on 275mm BC Assembly ABS | Includes items 3-5 for Steel Wheels |
| ns | 8-396-8 | 1 | Hub 8 Stud on 275mm BC Assembly ABS | Includes items 3-5 for Aluminum Wheels |
| ns | 24-2-1 | 1 | ABS Tone Ring | Included with ABS Hubs |
| 3 | 31-26-1 | 1 | Inner Bearing Cup (HM218210) | |
| 4 | 31-27-1 | 1 | Outer Bearing Cup (HM212011) | |
| 5 | 7-194 | 8 | Stud, Press-In M22 x 1.5 | 2.47" Stud Length for Steel Wheels |
| 5 | 7-195 | 8 | Stud, Press-In M22 x 1.5 | 3.32" Stud Length for Aluminum Wheels |
| 6 | 9-116 | 1 | Drum 12 1/4" x 7 1/2" | |
| 10 | 6-118 | 8 | Swivel Flange Nut | |
| 11 | 71-124 | 1 | Gasket - Oil Cap | |
| 12 | 21-38-2 | 1 | Oil Cap (with vent plug) | |
| 13 | 5-100 | 6 | Lock Washer | |
| 14 | 7-157 | 6 | Cap Screw | |
| ns - not shown | | | | |

Hub & Drum Dimensional Information

| Item | Description | Dimensions |
|----------------------------------------------------|-----------------------|--------------------------|
| A | Cup to Cup | 3.34" |
| B | Cup to Mounting Face | .75" |
| C | Cup to End of Drum | 10.43" |
| D | Brake Diameter | 12.25" |
| E | Shoe Brake Width | 7.50" |
| F | Drum Overall Width | 11.22" |
| G | Pilot Diameter 9Drum) | 9.00" |
| H | Bolt Circle | 275mm (10.827") |
| I | Bolt Diameter | M22 x 1.5 |
| J | Hub Cap Hole Mtg. | 5/16" 6 Holes 5.50 BC |
| Inner Bearing Cup and Cone Overall Stack Thickness | | 1.575" |

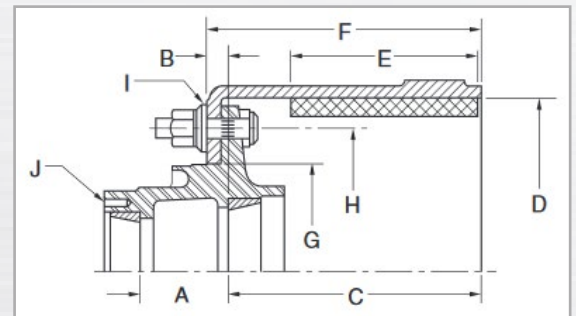



Hubs & Drums 16 1/2" x 7" Brake Size 10 Stud on 11 1/4" Hubs with Inboard Drums

For use with 20", 22.5" or 24.5" ball seat mounted steel disc wheels

C

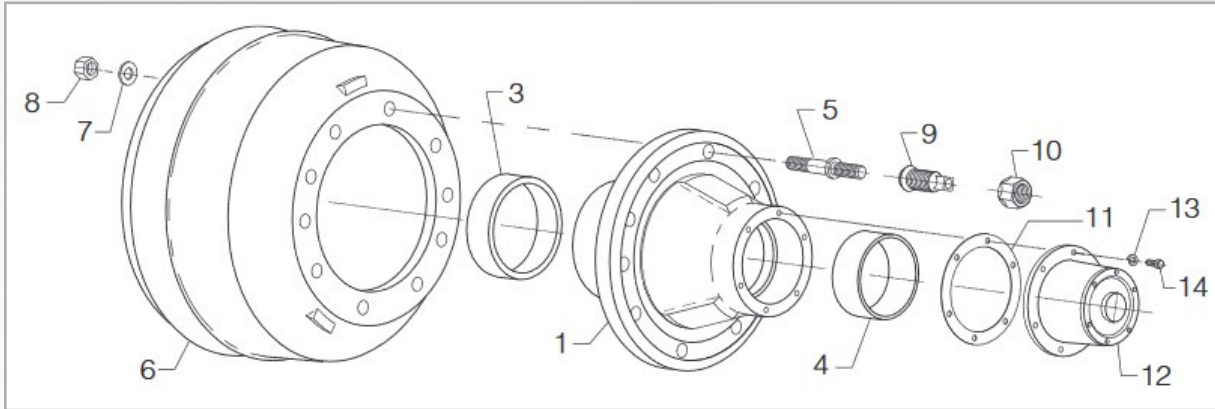

| Item | Part Number | Qty per Axle | Description | Comments |
|------|-------------|--------------|-------------------------------------------|---------------------------------|
| 0 | 8-279-71 | 1 | LH Assembly Hub & Drum 10 Stud 11 1/4" BC | Use Ball Seat Mtg. Steel Wheels |
| 0 | 8-279-7 | 1 | RH Assembly Hub & Drum 10 Stud 11 1/4" BC | Use Ball Seat Mtg. Steel Wheels |
| 1 | 8-279-4 | 1 | LH Assembly Hub 10 Stud 11 1/4" BC | Includes items 3-5 |
| 1 | 8-279-5 | 1 | RH Assembly Hub 10 Stud 11 1/4" BC | Includes items 3-5 |
| 3 | 31-26-1 | 1 | Inner Bearing Cup (HM218210) | |
| 4 | 31-27-1 | 1 | Outer Bearing Cup (HM212011) | |
| 5 | 25-56-2 | 10 | LH Shoulder Stud | |
| 5 | 25-56-1 | 10 | RH Shoulder Stud | |
| 6 | 9-42-1 | 1 | Drum 16 1/2" x 7" | |
| 7 | 5-102 | 10 | Washer | |
| 8 | 6-47 | 10 | Hex Nut - Drum Mounting | |
| 9 | 6-69-2 | 10 | LH Inner Cap Nut | For Steel Disc Wheels |
| 9 | 6-69-1 | 10 | RH Inner Cap Nut | For Steel Disc Wheels |
| 10 | 6-70-2 | 10 | LH Outer Cap Nut | |
| 10 | 6-70-1 | 10 | RH Outer Cap Nut | |
| 11 | 71-124 | 1 | Gasket - Oil Cap | |
| 12 | 21-38-2 | 1 | Oil Cap (with vent plug) | |
| 13 | 5-100 | 6 | Lock Washer - Oil Cap | |
| 14 | 7-157 | 6 | Cap Screw - Oil Cap | |

ns - not shown

HUBS AND COMPONENTS

Hub & Drum Dimensional Information

| Item | Description | Dimensions |
|----------------------------------------------------|----------------------|--------------------------|
| A | Cup to Cup | 3.34" |
| B | Cup to Mounting Face | .81" |
| C | Cup to End of Drum | 9.89" |
| D | Brake Diameter | 16.50" |
| E | Shoe Brake Width | 7.00" |
| F | Drum Overall Width | 9.58" |
| G | Pilot Diameter | 9.44" |
| H | Bolt Circle | 11.25" |
| I | Bolt Diameter | 3/4" |
| J | Hub Cap Hole Mtg. | 5/16" 6 Holes 5.50 BC |
| Inner Bearing Cup and Cone Overall Stack Thickness | | 1.575" |

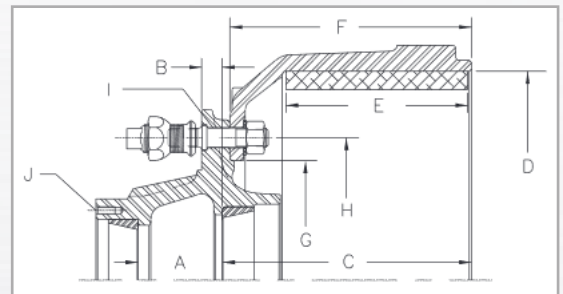

Hubs & Drums 16 1/2" x 7" Brake Size 10 Stud on 11 1/4" Hubs with Outboard Drums

For use with 20", 22.5" or 24.5" ball seat mounted steel disc wheels

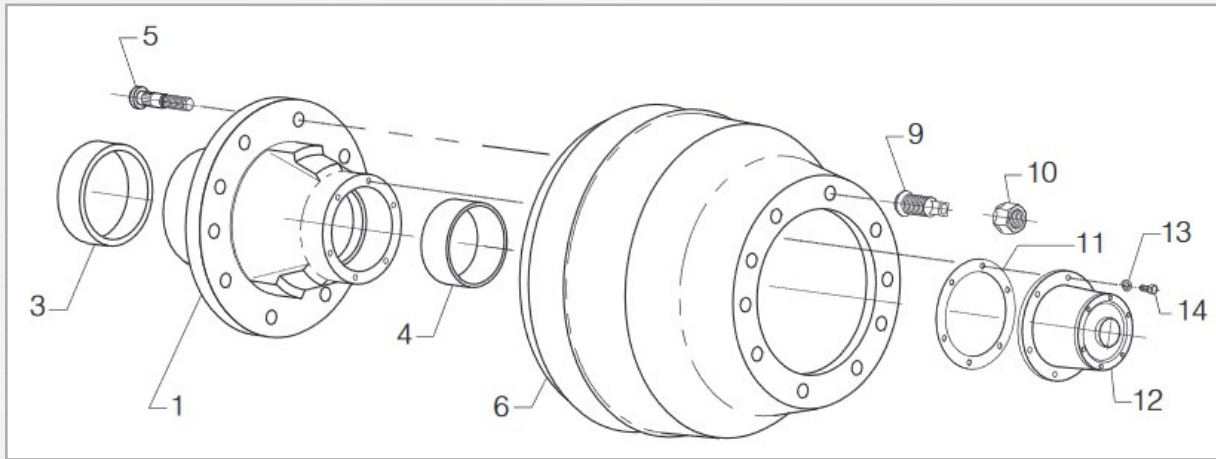

HUBS AND COMPONENTS

| Item | Part Number | Qty per Axle | Description | Comments |
|------|-------------|--------------|-----------------------------------------------|---------------------------------|
| 0 | 8-29-8 | 1 | LH Assembly Hub & Drum 10 Stud 11 1/4" BC | Use Ball Seat Mtg. Steel Wheels |
| 0 | 8-29-79 | 1 | RH Assembly Hub & Drum 10 Stud 11 1/4" BC | Use Ball Seat Mtg. Steel Wheels |
| ns | 8-29-82 | 1 | LH Assembly Hub & Drum 10 Stud 11 1/4" BC ABS | Use Ball Seat Mtg. Steel Wheels |
| ns | 8-29-81 | 1 | RH Assembly Hub & Drum 10 Stud 11 1/4" BC ABS | Use Ball Seat Mtg. Steel Wheels |
| 1 | 8-29-68 | 1 | LH Assembly Hub 10 Stud 11 1/4" BC | Includes items 3-5 |
| 1 | 8-29-67 | 1 | RH Assembly Hub 10 Stud 11 1/4" BC | Includes items 3-5 |
| ns | 8-29-7 | 1 | LH Assembly Hub 10 Stud 11 1/4" BC ABS | Includes items 3-5 |
| ns | 8-29-69 | 1 | RH Assembly Hub 10 Stud 11 1/4" BC ABS | Includes items 3-5 |
| ns | 24-20-1 | 1 | ABS Tone Ring | Included with ABS Hubs |
| 3 | 31-26-1 | 1 | Inner Bearing Cup (HM218210) | |
| 4 | 31-27-1 | 1 | Outer Bearing Cup (HM212011) | |
| 5 | 7-242-1 | 10 | LH Stud, Press-In | 1.38" Stud Stand Out Length |
| 5 | 7-242-0 | 10 | RH Stud, Press-In | 1.38" Stud Stand Out Length |
| 6 | 9-43-3 | 1 | Drum 16 1/2" x 7" | |
| 9 | 6-69-2 | 10 | LH Inner Cap Nut | For Steel Disc Wheels |
| 9 | 6-69-1 | 10 | RH Inner Cap Nut | For Steel Disc Wheels |
| 9 | 6-124-2 | 10 | LH Inner Cap Nut | For Aluminum Disc Wheels |
| 9 | 6-124-1 | 10 | RH Inner Cap Nut | For Aluminum Disc Wheels |
| 10 | 6-70-2 | 10 | LH Outer Cap Nut | |
| 10 | 6-70-1 | 10 | RH Outer Cap Nut | |
| 11 | 71-124 | 1 | Gasket - Oil Cap | |
| 12 | 21-38-2 | 1 | Oil Cap (with vent plug) | |
| 13 | 5-100 | 6 | Lock Washer - Oil Cap | |
| 14 | 7-157 | 6 | Cap Screw - Oil Cap | |

ns - not shown

Hub & Drum Dimensional Information

| Item | Description | Dimensions |
|----------------------------------------------------|----------------------|------------|
| A | Cup to Cup | 3.34" |
| B | Cup to Mounting Face | .73" |
| C | Cup to End of Drum | 9.87" |
| D | Brake Diameter | 16.50" |
| E | Shoe Brake Width | 7.00" |
| F | Drum Overall Width | 10.60" |
| G | Pilot Diameter | 8.78" |
| H | Bolt Circle | 11.25" |
| I | Bolt Diameter | 3/4" |
| J | Hub Cap Hole Mtg. | 5/16" |
| Inner Bearing Cup and Cone Overall Stack Thickness | | 1.575" |

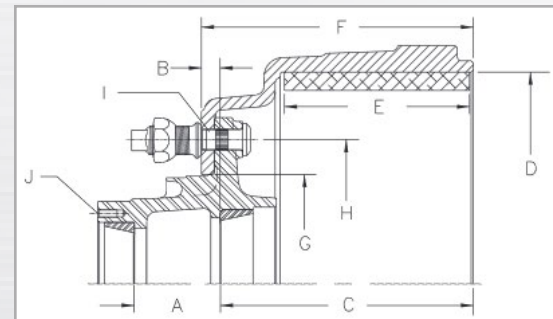



Hubs & Drums 16 1/2" x 7" Brake Size 10 Stud on 285.75mm (11.25") Hub Piloted with Outboard Drums

C

For use with 20", 22.5" or 24.5" 220mm piloted disc wheels

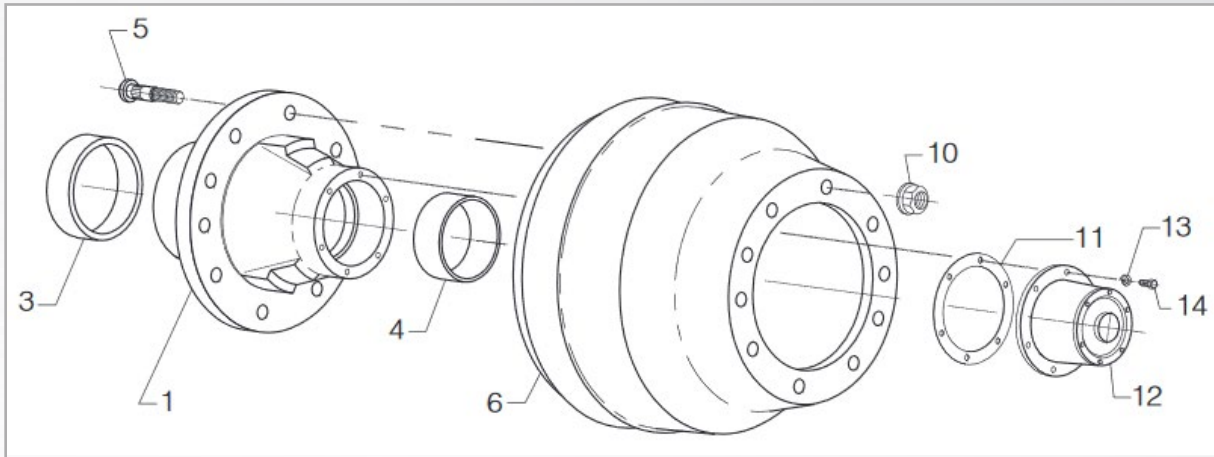

| Item | Part Number | Qty per Axle | Description | Comments |
|----------------|-------------|--------------|---------------------------------------------|----------------------------------------|
| 0 | 8-29-32 | 1 | Assembly Hub & Drum 10 Stud 285.75mm BC | Use Pilot Mtg. Steel Wheels |
| ns | 8-29-34 | 1 | Assembly Hub & Drum 10 Stud 285.75mm BC | Use Pilot Mtg. Aluminum Wheels |
| ns | 8-29-33 | 1 | Assembly Hub & Drum 10 Stud 285.75mm BC ABS | Use Pilot Mtg. Steel Wheels |
| ns | 8-29-35 | 1 | Assembly Hub & Drum 10 Stud 285.75mm BC ABS | Use Pilot Mtg. Aluminum Wheels |
| 1 | 8-29-13 | 1 | Assembly Hub 10 Stud 285.75mm | Includes items 3-5 for Steel Wheels |
| ns | 8-29-14 | 1 | Assembly Hub 10 Stud 285.75mm | Includes items 3-5 for Aluminum Wheels |
| ns | 8-26-16 | 1 | Assembly Hub 10 Stud 285.75mm ABS | Includes items 3-5 for Steel Wheels |
| ns | 8-29-17 | 1 | Assembly Hub 10 Stud 285.75mm ABS | Includes items 3-5 for Aluminum Wheels |
| ns | 24-20-1 | 1 | ABS Tone Ring | Included with ABS hubs |
| 3 | 31-26-1 | 1 | Inner Bearing Cup (HM218210) | |
| 4 | 31-27-1 | 1 | Outer Bearing Cup (HM212011) | |
| 5 | 7-194 | 10 | Stud, Press-In M22 x 1.5 | 2.47" Stud Length for Steel Wheels |
| 5 | 7-195 | 10 | Stud, Press-In M22 x 1.5 | 3.32" Stud Length for Aluminum Wheels |
| 6 | 9-43-3 | 1 | Drum 16 1/2" x 7" | |
| 10 | 6-118 | 10 | Swivel Flange Nut | |
| 11 | 71-124 | 1 | Gasket - Oil Cap | |
| 12 | 21-38-2 | 1 | Oil Cap (with vent plug) | |
| 13 | 5-100 | 6 | Lock Washer - Oil Cap | |
| 14 | 7-157 | 6 | Cap Screw - Oil Cap | |
| ns - not shown | | | | |

HUBS AND COMPONENTS

Hub & Drum Dimensional Information

| Item | Description | Dimensions |
|----------------------------------------------------|----------------------|--------------------------|
| A | Cup to Cup | 3.34" |
| B | Cup to Mounting Face | .73" |
| C | Cup to End of Drum | 9.87" |
| D | Brake Diameter | 16.50" |
| E | Shoe Brake Width | 7.00" |
| F | Drum Overall Width | 10.60" |
| G | Pilot Diameter | 8.78" |
| H | Bolt Circle | 285.75mm (11.25") |
| I | Bolt Diameter | M22 x 1.5 |
| J | Hub Cap Hole Mtg. | 5/16" 6 Holes 5.50 BC |
| Inner Bearing Cup and Cone Overall Stack Thickness | | 1.575" |

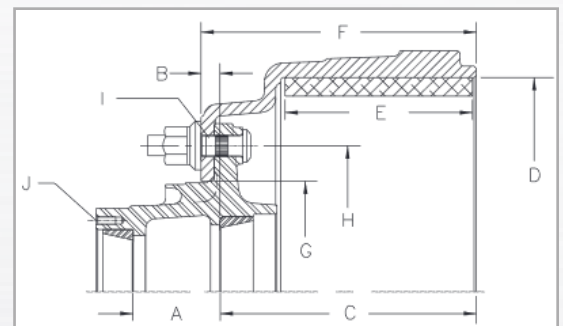

Hubs & Drums; Wheels & Drums Cross Reference



| Description | Dexter | Webb | Erie | Dayton Walther | KIC | Gunite |
|----------------------------------------------------------------------------|------------|---------------------------------------------|--------------------------------------------------|----------------|-----------------------|----------|
| Assembly 8 on 275mm BC; Outboard 12 1/4" Brake* | 008-396-70 | 20271CW4 | n/a | n/a | 001-00133 | n/a |
| Assembly 8 on 275mm BC; Outboard 12 1/4" Brake-ABS* | 008-396-71 | 20271CW4T | n/a | n/a | 001-00133T | n/a |
| Assembly 8 on 275mm BC; Outboard 12 1/4" Brake* | 008-396-72 | 20271CW6 | n/a | n/a | 001-00133L | n/a |
| Assembly 8 on 275mm BC; Outboard 12 1/4" Brake-ABS ¹ | 008-396-73 | 20271CW6T | n/a | n/a | 001-00133LT | n/a |
| Assembly 10 on 8 3/4" BC RH; Inboard 12 1/4" Brake* | 008-277-70 | 10519CLMR | n/a | n/a | 001-10511 | n/a |
| Assembly 10 on 8 3/4" BC RH; Inboard 12 1/4" Brake-ABS* | 008-277-28 | 10519CLMRT | n/a | n/a | 001-10511T | n/a |
| Assembly 10 on 8 3/4" BC LH; Inboard 12 1/4" Brake* | 008-277-71 | 10519CLML | n/a | n/a | 001-10512 | n/a |
| Assembly 10 on 8 3/4" BC LH; Inboard 12 1/4" Brake-ABS* | 008-277-29 | 10519CLMLT | n/a | n/a | 001-10512T | n/a |
| Assembly 15" 3-Spoke; 12 1/4" Brake | 008-269-xx | 70159CCA | 950-2700-10 | 48-14054-054 | 001-70003H | 5785-1 |
| Assembly 15" 3-Spoke; 12 1/4" Brake-ABS | 008-269-xx | 70159CCAI80 | 950-2700-10-A | 48-15613-056 | 001-70003IH | 5785-2 |
| Assy 10 on 11 1/4" BC RH; 9.44 Pilot Inboard 16 1/2" Brake* | 008-279-70 | 10019 BE_R | 704-2760 RH | n/a | n/a | 5559-RH1 |
| Assy 10 on 11 1/4" BC LH; 9.44 Pilot Inboard 16 1/2" Brake* | 008-279-71 | 10019 BF_L | 704-2760 LH | n/a | n/a | 5559-LH1 |
| Assy 10 on 11 1/4" BC RH; 8.78 Pilot Outboard 16 1/2" Brake* | 008-290-79 | 20231UQ_R | Call Erie sales office | n/a | 001-00126 | n/a |
| Assy 10 on 11 1/4" BC RH; 8.78 Pilot Outboard 16 1/2" Brake-ABS* | 008-290-81 | 20231UQ_RT | 814-452-6431 for assistance. | n/a | 001-00126T | n/a |
| Assy 10 on 11 1/4" BC LH; 8.78 Pilot Outboard 16 1/2" Brake* | 008-290-80 | 20231UQ_L | | n/a | 001-00127 | n/a |
| Assy 10 on 11 1/4" BC LH; 8.78 Pilot Outboard 16 1/2" Brake-ABS* | 008-290-82 | 20231UQ_LT | | n/a | 001-00127T | n/a |
| Assy 10 on 285.75mm BC; 8.78 Pilot Outboard 16 1/2" Brake* | 008-290-32 | Heavy Duty 20231UQ4 or Extra Hvy 20231UH4 | 706-2764-5 with 5324 Studs for Steel Wheels | n/a | Heavy Duty 001-00125 | n/a |
| Assy 10 on 285.75mm BC; 8.78 Pilot Outboard 16 1/2" Brake-ABS* | 008-290-33 | Heavy Duty 20231UQ4T or Extra Hvy 20231UH4T | 706-2764-5-A with 5424 Studs for Steel Wheels | n/a | Heavy Duty 001-0125T | n/a |
| Assy 10 on 285.75mm BC; 8.78 Pilot Outboard 16 1/2" Brake ¹ | 008-290-34 | Heavy Duty 20231UQ6 or Extra Hvy 20231UH6 | 706-2764-5-A with 5322 Studs for Aluminum Wheels | n/a | Heavy Duty 001-0125L | n/a |
| Assy 10 on 285.75mm BC; 8.78 Pilot Outboard 16 1/2" Brake-ABS ¹ | 008-290-35 | Heavy Duty 20231UQ6T or Extra Hvy 20231UH6T | 706-2764-5-A with 5322 Studs for Aluminum Wheels | n/a | Heavy Duty 001-0125LT | n/a |
| Assembly 20" 5-Spoke; 16 1/2" Brake | 008-267-xx | 75209GCA | 904-2738-1 | 48-14018-051 | 001-75207H | 5763-1 |
| Assembly 20" 5 Spoke; 16 1/2" Brake ABS | 008-267-xx | 75209GCAI | 904-2738-1A | n/a | 001-75207IH | 5763-2 |

xx - See Hubs & Drums section for part number that varies with manufacturer.

The following listed part numbers have a drum pilot diameter of 8.53". These are obsolete and are available as service parts only, not to be used for new construction.
For new assemblies having 8.78" diameter drum pilot, see the above part numbers 008-290-79; -80; -81; -82.

| Description | Dexter | Webb | Erie | Dayton Walther | KIC | Gunite |
|------------------------------------------------------------------|------------|------------|---------------|----------------|-----|----------|
| Assy 10 on 11 1/4" BC RH; 8.53 Pilot Outboard 16 1/2" Brake* | 008-290-20 | 10209FRMR | 705-2764 RH | n/a | n/a | 5631-RH1 |
| Assy 10 on 11 1/4" BC RH; 8.53 Pilot Outboard 16 1/2" Brake-ABS* | 008-290-57 | 10209FRMRT | 705-2764 RH-A | n/a | n/a | n/a |
| Assy 10 on 11 1/4" BC LH; 8.53 Pilot Outboard 16 1/2" Brake* | 008-290-21 | 10209FRML | 705-2764 LH | n/a | n/a | 5631-LH1 |
| Assy 10 on 11 1/4" BC LH; 8.53 Pilot Outboard 16 1/2" Brake-ABS* | 008-290-58 | 10209FRMLI | 705-2764 LH-A | n/a | n/a | n/a |

Interchange Reference Information

The interchange reference information listed herein is based on the best available information at the time of publication and is to be used at a guide only. Although every care has been taken in order to ensure the accuracy of these interchanges, Dexter does not assume any liability for errors, changes, omissions, or for harm resulting therefrom. It is recommended that all parts be thoroughly checked for proper form, fit and function prior to installation and usage to determine interchangeability.

- * Steel Wheels
- + Aluminum Wheels

Section D

Brakes and Components

| | |
|-----------------------------|----------------|
| 1000-2200lb Capacity | D-1 & D-2 |
| 2300-4000lb Capacity | D-3 thru D-5 |
| 4100-6000lb Capacity | D-6 thru D-8 |
| 5500-7000lb Capacity | D-9 thru D-14 |
| 7200lb Capacity | D-15 & D-16 |
| 8000lb Capacity | D-17 thru D-19 |
| Electric Brakes | D-20 thru D-22 |
| Hydraulic Brakes | D-23 thru D-25 |
| Air Brakes | D-26 |
| Axle/Brake Components | D-27 & D28 |
| Camshafts | D-29 |
| Air Chambers | D-30 |



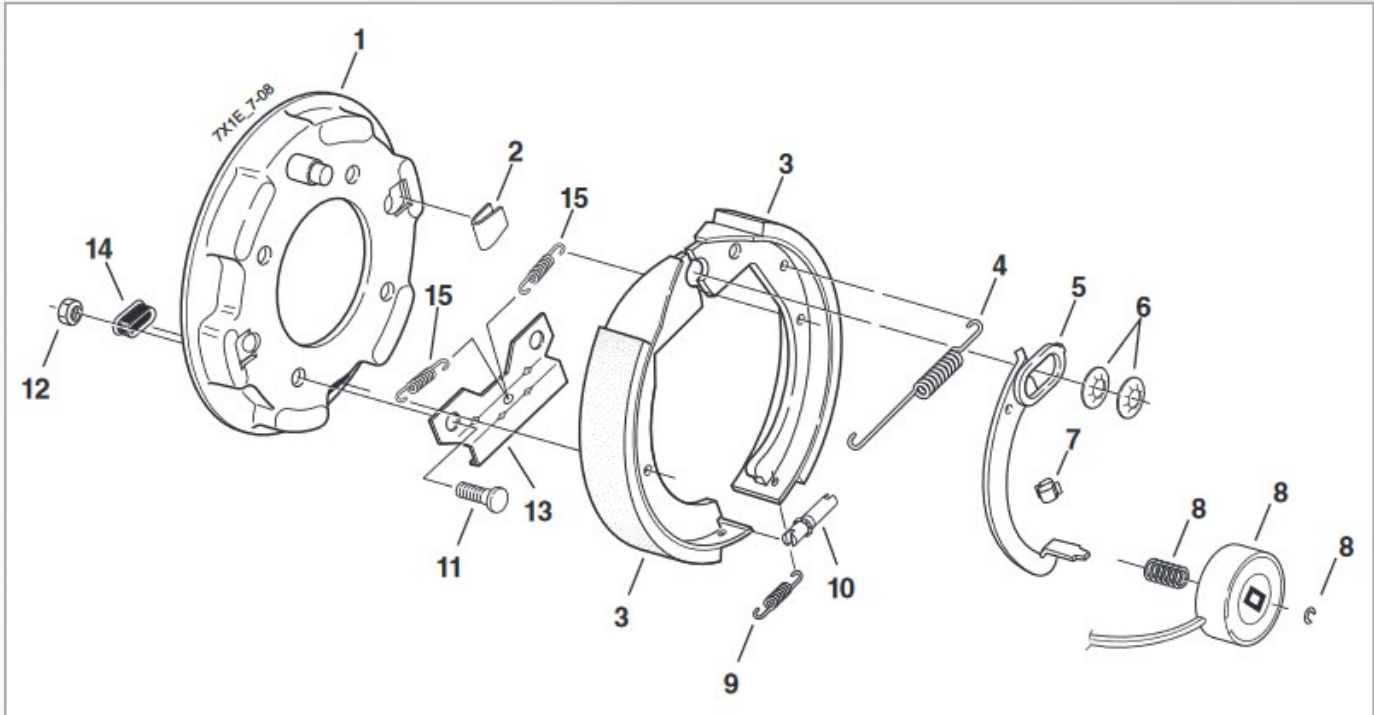

Electric Brake

This brake is rated to a maximum capacity of 2200lbs / pair.

| Item | Part Number | Qty per Brake | Description |
|---------------------------------------------|-------------|---------------|------------------------------------------------------------------------------------------------------|
| 0 | K23-47 | 1 | LH Complete Brake Assembly (shown) |
| 0 | K23-48 | 1 | RH Complete Brake Assembly |
| 1 | 36-36-4 | 1 | Backing Plate Assembly (Includes items 11 & 13) |
| 2 | 46-23 | 2 | Shoe Hold Down Clip |
| 3 | K71-45 | 1 | Shoe and Lining Kit Contains: 1 #40-125 Primary Shoe & Lining 1 #40-49 Secondary Shoe & Lining |
| 4 | 46-24 | 1 | Retractor Spring |
| 5 | 47-114-3 | 1 | LH Actuating Lever Arm |
| 5 | 47-115-3 | 1 | RH Actuating Lever Arm |
| 6 | 46-30 | 2 | Anchor Post Clip |
| 7 | 27-05 | 1 | Wire Clip |
| For brakes manufactured after 4/1/90 | | | |
| 8 | K71-57 | 1 | Magnet Kit Contains: 1 #42-134 Magnet 1 #46-121 Magnet Clip 1 #46-86 Magnet Spring |
| 9 | 46-22 | 1 | Adjusting Screw Spring |
| 10 | 43-21 | 1 | Adjusting Screw |
| 11 | 7-41 | 4 | Brake Mounting Bolt - Press-In |
| *12 | 6-17 | 4 | Brake Mounting Nut |
| 13 | 64-01 | 1 | Stabilizer Bracket |
| 14 | 46-07 | 1 | Adjuster Slot Plug |
| For brakes manufactured after 8/1/91 | | | |
| 15 | 46-114 | 2 | Shoe Centering Spring |

* Not included with complete brake assembly. Item sold separately.

1000 - 2200 LBS CAPACITY

7" x 1³/₄" Hydraulic Brake

CSA approved at 2500#/11.2 SLR

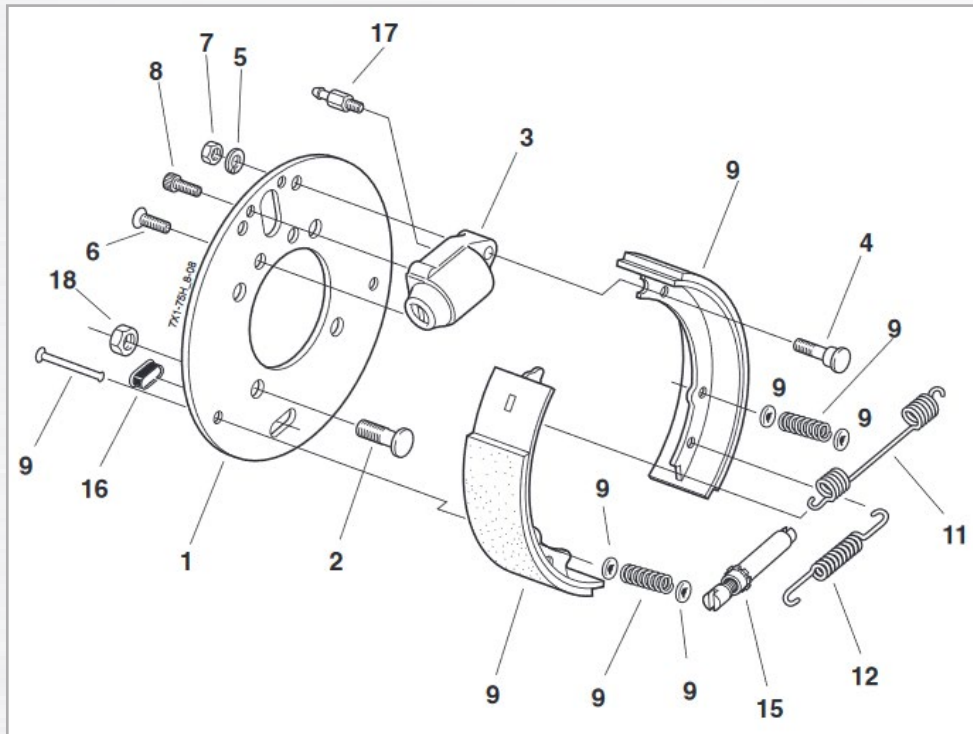

Hydraulic Brake

This brake is rated to a maximum capacity of 2500lbs / pair.

| Item | Part Number | Qty per Brake | Description |
|------|-------------|---------------|-------------------------------------------------|
| 0 | K23-398 | 1 | LH Complete Brake Assembly (shown) |
| 0 | K23-399 | 1 | RH Complete Brake Assembly |
| 1 | 36-38 | 1 | Backing Plate |
| 2 | 7-41 | 4 | Brake Mounting Bolt - Press-in |
| 3 | 54-8-3 | 1 | Wheel Cylinder Assembly - LH (includes item 17) |
| 3 | 54-8-4 | 1 | Wheel Cylinder Assembly - RH (includes item 17) |
| 4 | 38-72 | 1 | Anchor Post |
| 5 | 5-04 | 1 | Lock Washer |
| 6 | 7-235 | 1 | Counter Sunk Cap Screw |
| 7 | 6-10 | 1 | Hex Nut |
| 8 | 7-234 | 1 | Socket Head Cap Screw |
| 9 | K71-466 | 1 | Shoe & Lining Kit Contains: |
| | | 1 | #4-327-1 Primary Shoe & Lining |
| | | 1 | #4-328-1 Secondary Shoe & Lining |
| | | 2 | #46-06 Shoe Hold Down Spring |
| | | 4 | #35-01 Shoe Hold Down Spring Cup |
| | | 2 | #49-14 Shoe Hold Down Pin |
| 11 | 46-126 | 1 | Retractor Spring |
| 12 | 46-127 | 1 | Adjusting Screw Spring |
| 15 | 43-04 | 1 | Adjuster Screw Assembly |
| 16 | 46-07 | 1 | Adjuster Slot Plug |
| 17 | 54-84 | 1 | Bleeder Screw 6mm Thread (brakes before 1/97) |
| 17 | 54-88 | 1 | Bleeder Screw 7mm Thread (brakes after 1/97) |
| *18 | 6-17 | 4 | Brake Mounting Nut |

* Not included with complete brake assembly. Item sold separately.

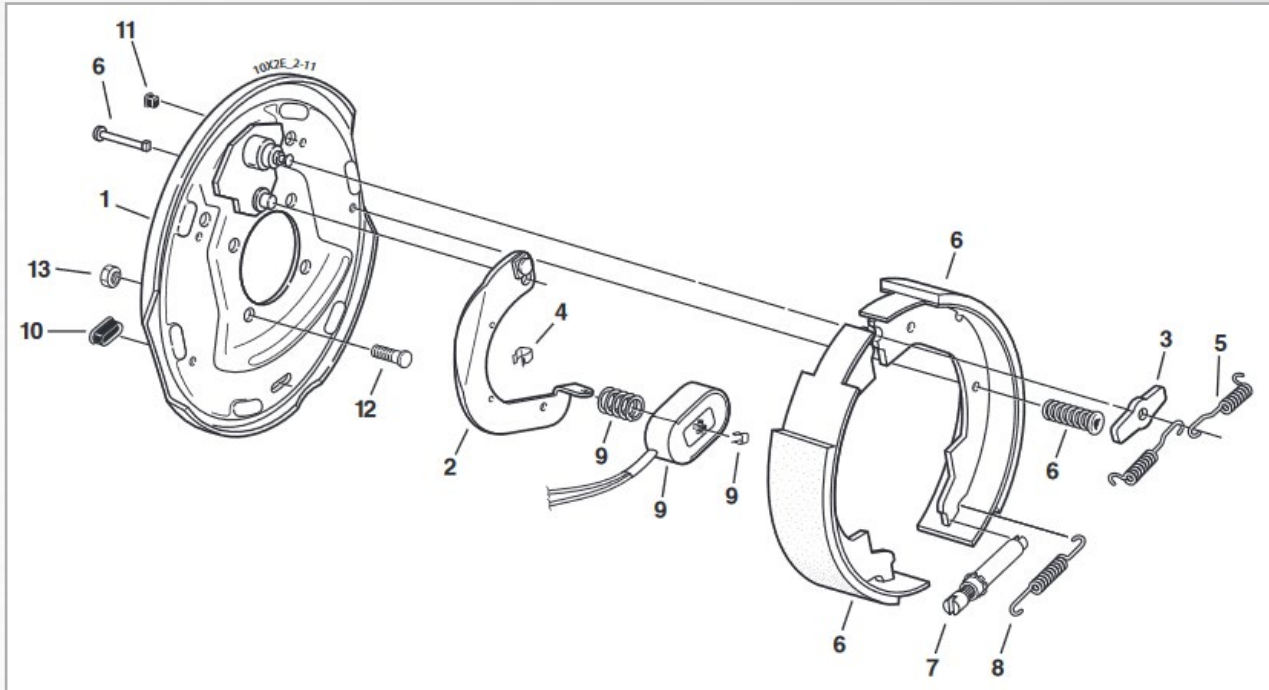

Electric Brake

| Item | Part Number | Qty per Brake | Description |
|------|-------------|---------------|-----------------------------------------------------------------------------------------------------------------------------------------------------------------------------|
| 0 | K23-26 | 1 | LH Complete Brake Assembly (shown) |
| 0 | K23-27 | 1 | RH Complete Brake Assembly |
| 1 | 36-19-1 | 1 | Backing Plate Assembly |
| 2 | 47-19-5 | 1 | LH Actuating Lever Arm |
| 2 | 47-20-5 | 1 | RH Actuating Lever Arm |
| 3 | 5-67 | 1 | Washer |
| 4 | 27-05 | 2 | Wire Clip |
| 5 | 46-09 | 2 | Retractor Spring |
| 6 | K71-47 | 1 | Shoe & Lining Kit Contains: 1 #40-17 Primary Shoe & Lining 1 #40-21 Secondary Shoe & Lining 2 #49-02 Shoe Hold Down Pin #8 2 #46-77 Shoe Hold Down Spring & Cup |
| 7 | 43-04 | 1 | Adjuster Assembly |
| 8 | 46-18 | 1 | Adjusting Screw Spring |
| 9 | K71-104 | 1 | Magnet Kit Contains: 1 #42-14 Magnet (green wire) 1 #27-09 Magnet Clip 1 #46-80 Magnet Spring (before 7/16) 1 #46-175 Magnet Spring (after 7/16) |
| 10 | 46-07 | 2 | Adjuster Slot Plug |
| 11 | 46-16 | 1 | Wire Grommet |
| 12 | 7-41 | 4 | Brake Mounting Bolt - Press-In |
| *13 | 6-17 | 4 | Brake Mounting Nut |

* Not included with complete brake assembly. Item sold separately.

2300 - 4000 LBS CAPACITY

D35, #10 10" x 2 1/4" Nev-R-Adjust® Electric Brake

CSA approved at 3500#/13.3 SLR

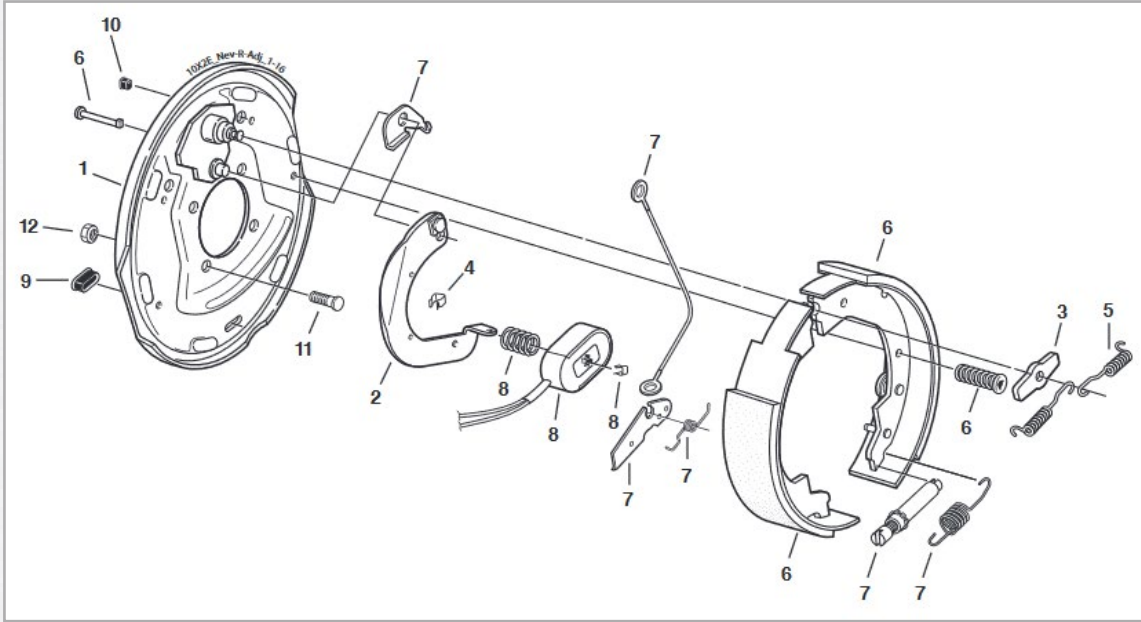

Electric Brake

| Item | Part Number | Qty per Brake | Description |
|------|--------------|---------------|--------------------------------------------------------------------------------------------------------------------------------------------------------------------------------------------------------------------------------------------------------------------------------------------------------------------------------------------------------------------------------------------------------------------------|
| 0 | K23-468 | 1 | LH Complete Brake Assembly (shown) |
| 0 | K23-469 | 1 | RH Complete Brake Assembly |
| 1 | 36-19-1 | 1 | Backing Plate Assembly |
| 2 | 47-19-1 | 1 | LH Actuating Lever Arm |
| 2 | 47-20-1 | 1 | RH Actuating Lever Arm |
| 3 | 5-67 | 1 | Washer |
| 4 | 27-05 | 2 | Wire Clip |
| 5 | 46-09 | 2 | Retractor Spring |
| 6 | K71-681 (LH) | 1 | LH Shoe & Lining Kit Contains: 1 #40-367 Primary Shoe & Lining 1 #40-368-1 Secondary Shoe & Lining 2 #49-02 Shoe Hold Down Pin #8 2 #46-77 Shoe Hold Down Spring & Cup |
| | K71-682 (RH) | 1 | RH Shoe & Lining Kit Contains: 1 #40-367 Primary Shoe & Lining 1 #40-368-2 Secondary Shoe & Lining 2 #49-02 Shoe Hold Down Pin #8 2 #46-77 Shoe Hold Down Spring & Cup |
| 7 | K71-703 | 1 | LH & RH Brake Adjuster Kit Contains: 2 #46-139 Adjusting Screw Spring 1 #46-140 LH Lever Spring 1 #46-141 RH Lever Spring 1 #48-22 LH Adjuster Assembly 1 #48-23 RH Adjuster Assembly 2 #71-529 Hook for Cable 1 #71-532-1 LH Adjusting Lever 1 #71-532-2 RH Adjusting Lever 2 #71-533 Adjuster Cable 1 #71-655-1 LH Cable Lever 1 #71-655-2 RH Cable Lever 2 #71-656 Adjuster Cable |
| 8 | K71-104 | 1 | Magnet Kit Contains: 1 #42-14 Magnet (green wire) 1 #27-09 Magnet Clip 1 #46-80 Magnet Spring (before 7/16) 1 #46-175 Magnet Spring (after 7/16) |
| 9 | 46-07 | 2 | Adjuster Slot Plug |
| 10 | 46-16 | 1 | Wire Grommet |
| 11 | 7-41 | 4 | Brake Mounting Bolt - Press-In |
| *12 | 6-17 | 4 | Brake Mounting Nut |

* Not included with complete brake assembly. Item sold separately.

BRAKES AND COMPONENTS

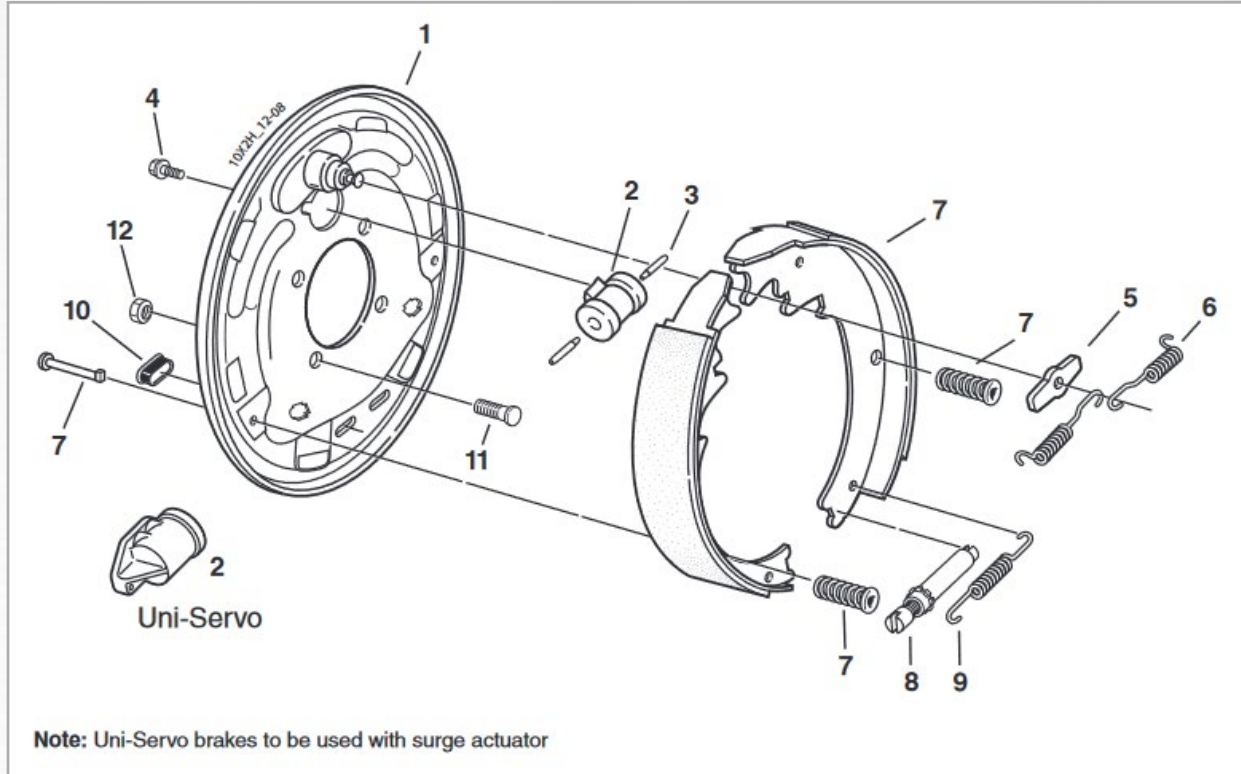

Hydraulic Brake

| Item | Part Number | Qty per Brake | Description |
|------|-------------|---------------|-----------------------------------------------------------------------------------------------------------------------------------------------------------------------------|
| 0 | K23-31 | 1 | LH Complete Brake Assembly - DS |
| 0 | K23-311 | 1 | RH Complete Brake Assembly - DS |
| 0 | K23-312 | 1 | LH Complete Brake Assembly - US |
| 0 | K23-313 | 1 | RH Complete Brake Assembly - US (shown) |
| 1 | 36-94-3 | 1 | Backing Plate Assembly (includes item 11) |
| 2 | 54-62 | 1 | LH Brake Cylinder Duo-Servo |
| 2 | 54-63 | 1 | RH Brake Cylinder Duo-Servo |
| 2 | 54-64 | 1 | LH Brake Cylinder Uni-Servo |
| 2 | 54-65 | 1 | RH Brake Cylinder Uni-Servo |
| 3 | 54-60 | 1 or 2 | Cylinder Push Rod US (1) DS (2) |
| 4 | 87-01 | 2 | Sems (Screw & Washer Assembly) |
| 5 | 5-113 | 1 | Anchor Post Washer |
| 6 | 46-09 | 2 | Retractor Spring |
| 7 | K71-267 | 1 | Shoe & Lining Kit Contains: 1 #4-210 Primary Shoe & Lining 1 #4-211 Secondary Shoe & Lining 2 #46-77 Shoe Hold Down Spring & Cup 2 #49-02 Shoe Hold Down Pin #8 |
| 8 | 43-04 | 1 | Adjuster Assembly |
| 9 | 46-18 | 1 | Adjusting Screw Spring |
| 10 | 46-07 | 1 | Adjuster Slot Plug |
| 11 | 7-41 | 4 | Brake Mounting Bolt - Press-In |
| *12 | 6-17 | 4 | Brake Mounting Nut |
| ns | 54-89 | 1 | Bleeder Screw (included with item 2) |

* Not included with complete brake assembly. Item sold separately.
 ns - not shown

4100 - 6000 LBS CAPACITY D52, D60 12" x 2" Electric Brake

CSA approved at 6000#/14.2 SLR

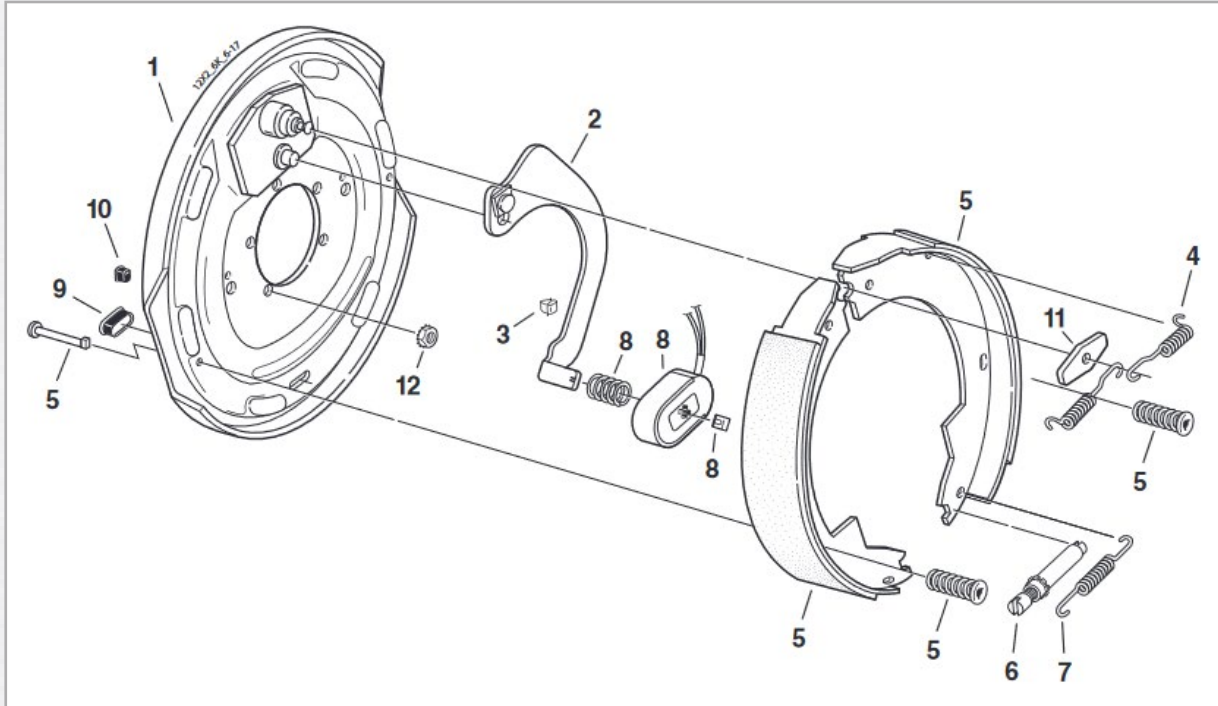

BRAKES AND COMPONENTS

Electric Brake 6000# (CSA 6000#)

| Item | Part Number | Qty per Brake | Description |
|------|-------------|---------------|-------------------------------------------------------------------------------------------------------------------------------------------------------------------------------|
| 0 | K23-105 | 1 | LH Complete Brake Assembly (shown) |
| 0 | K23-106 | 1 | RH Complete Brake Assembly |
| 1 | 36-89-1 | 1 | Backing Plate Assembly |
| 2 | 47-107-5 | 1 | LH Actuating Lever Arm Assembly |
| 2 | 47-108-5 | 1 | RH Actuating Lever Arm Assembly |
| 3 | 27-05 | 2 | Wire Clip |
| 4 | 46-09 | 2 | Retractor Spring |
| 5 | K71-127 | 1 | Shoe & Lining Kit Contains: 1 #40-215 Primary Shoe & Lining 1 #40-216 Secondary Shoe & Lining 2 #49-11 Shoe Hold Down Pin #8 2 #46-77 Shoe Hold Down Spring & Cup |
| 6 | 43-4 | 1 | Adjuster Assembly |
| 7 | 46-18 | 1 | Adjusting Screw Spring |
| 8 | K71-105 | 1 | Magnet Kit Contains: 1 #42-149 Magnet (green wire) 1 #27-09 Magnet Clip 1 #46-80 Magnet Spring (before 7/16) 1 #46-175 Magnet Spring (after 7/16) |
| 9 | 46-07 | 2 | Adjuster Slot Plug |
| 10 | 46-16 | 1 | Wire Grommet |
| 11 | 5-67 | 1 | Anchor Post Washer |
| *12 | 6-193 | 5 | Nut Washer Assembly |

* Not included with complete brake assembly. Item sold separately.

4100 - 6000 LBS CAPACITY

D52, D60 12" x 2" Nev-R-Adjust® Electric Brake

CSA approved at 6000#/14.2 SLR

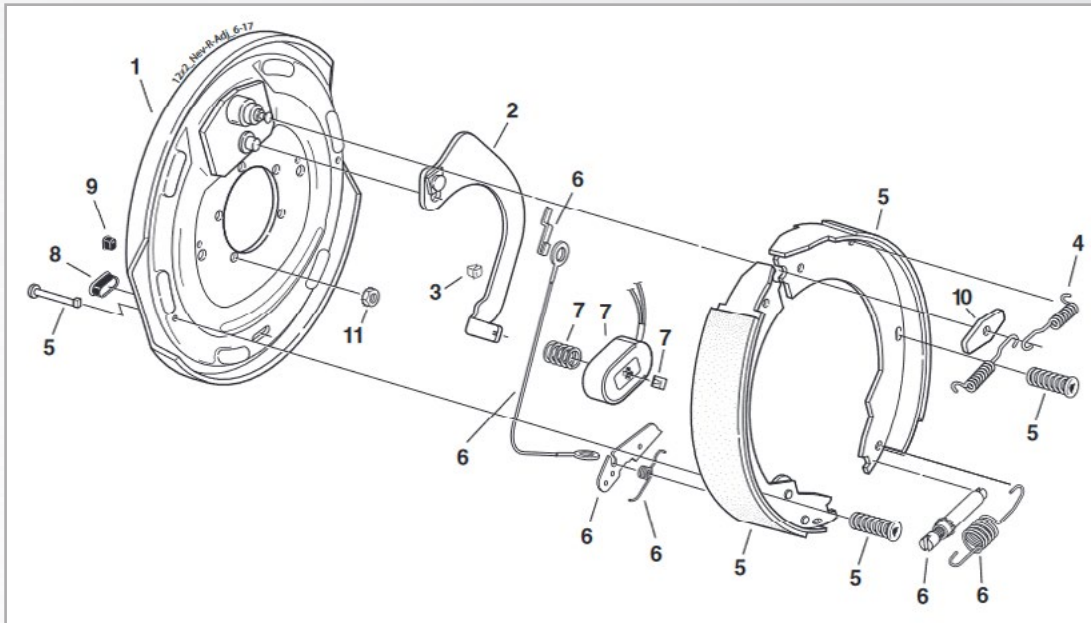

Electric Brake 6000# (CSA 6000#)

| Item | Part Number | Qty per Brake | Description |
|------|--------------|---------------|--------------------------------------------------------------------------------------------------------------------------------------------------------------------------------------------------------------------------------------------------------------------------------------------------------------------------------|
| 0 | K23-458 | 1 | LH Complete Brake Assembly (shown) |
| 0 | K23-459 | 1 | RH Complete Brake Assembly |
| 1 | 36-89-1 | 1 | Backing Plate Assembly |
| 2 | 47-107-5 | 1 | LH Actuating Lever Arm Assembly |
| 2 | 47-108-5 | 1 | RH Actuating Lever Arm Assembly |
| 3 | 27-05 | 2 | Wire Clip |
| 4 | 46-09 | 2 | Retractor Spring |
| 5 | K71-675 (LH) | 1 | LH Shoe & Lining Kit Contains: 1 #40-215 Primary Shoe & Lining 1 #40-216-1 Secondary Shoe & Lining 2 #49-11 Shoe Hold Down Pin #2 2 #46-77 Shoe Hold Down Spring & Cup |
| 5 | K71-676 (RH) | 1 | RH Shoe & Lining Kit Contains: 1 #40-215 Primary Shoe & Lining 1 #40-216-2 Secondary Shoe & Lining 2 #49-11 Shoe Hold Down Pin #2 2 #46-77 Shoe Hold Down Spring & Cup |
| 6 | K71-679 | 1 | LH & RH Brake Adjuster Kit Contains: 2 #46-139 Adjusting Screw Spring 1 #46-140 LH Lever Spring 1 #46-141 RH Lever Spring 1 #48-22 LH Adjuster Assembly 1 #48-23 RH Adjuster Assembly 2 #71-528 Adjuster Cable 2 #71-529 Hook for Cable 1 #71-53-1 LH Adjusting Lever 1 #71-53-2 RH Adjusting Lever |
| 7 | K71-104 | 1 | Magnet Kit Contains: 1 #42-149 Magnet (green wire) 1 #27-09 Magnet Clip 1 #46-80 Magnet Spring (before 7/16) 1 #46-175 Magnet Spring (after 7/16) |
| 8 | 46-07 | 2 | Adjuster Slot Plug |
| 9 | 46-16 | 1 | Wire Grommet |
| 10 | 5-67 | 1 | Anchor Post Washer |
| *11 | 6-193 | 5 | Nut Washer Assembly |

* Not included with complete brake assembly. Item sold separately.

4100 - 6000 LBS CAPACITY D52, D60 12" x 2" Hydraulic Brake

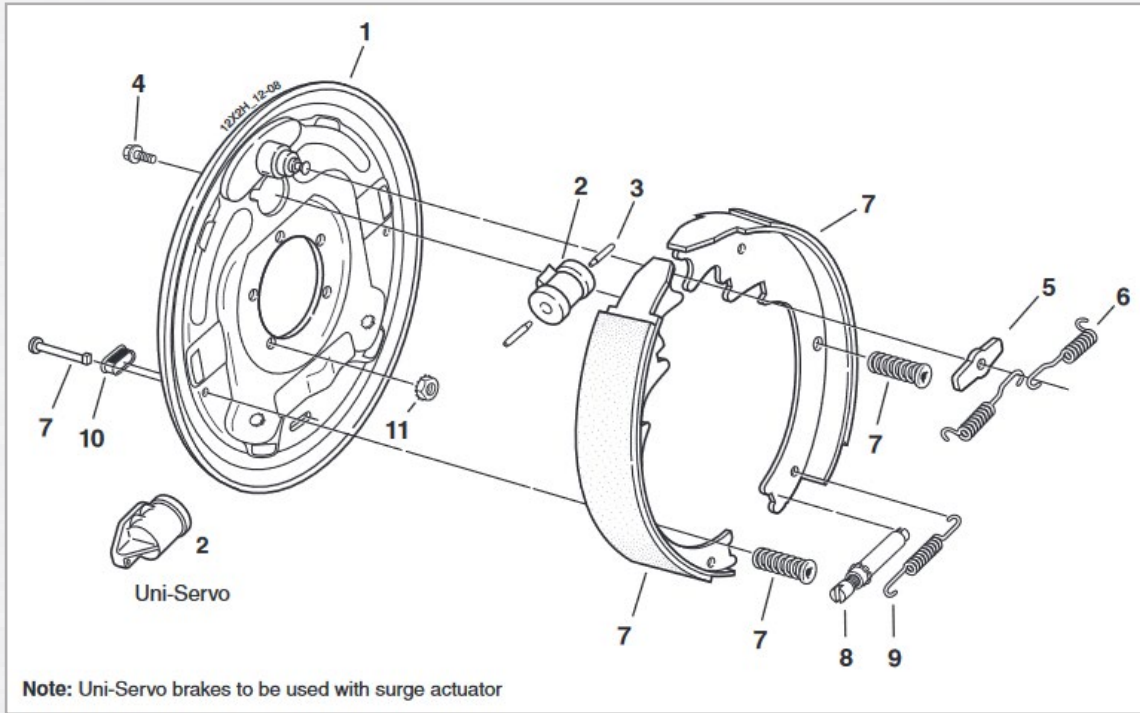

BRAKES AND COMPONENTS

Hydraulic Brake 5200#

| Item | Part Number | Qty per Brake | Description |
|------|-------------|---------------|-----------------------------------------------------------------------------------------------------------------------------------------------------------------------------|
| 0 | K23-322 | 1 | LH Complete Brake Assembly - DS |
| 0 | K23-323 | 1 | RH Complete Brake Assembly - DS (shown) |
| 0 | K23-324 | 1 | LH Complete Brake Assembly - US |
| 0 | K23-325 | 1 | RH Complete Brake Assembly - US (shown) |
| 1 | 36-93-3 | 1 | Backing Plate Assembly |
| 2 | 54-62 | 1 | LH Brake Cylinder Duo-Servo |
| 2 | 54-63 | 1 | RH Brake Cylinder Duo-Servo |
| 2 | 54-64 | 1 | LH Brake Cylinder Uni-Servo |
| 2 | 54-65 | 1 | RH Brake Cylinder Uni-Servo |
| 3 | 54-60 | 1 or 2 | Cylinder Push Rod US (1) DS (2) |
| 4 | 87-01 | 2 | Sems (Screw & Washer Assembly) |
| 5 | 5-113 | 1 | Anchor Post Washer |
| 6 | 46-101 | 2 | Retractor Spring |
| 7 | K71-268 | 1 | Shoe & Lining Kit Contains: 1 #4-204 Primary Shoe & Lining 1 #4-206 Secondary Shoe & Lining 2 #46-77 Shoe Hold Down Spring & Cup 2 #49-12 Shoe Hold Down Pin #4 |
| 8 | 43-29 | 1 | Adjuster Assembly |
| 9 | 46-102 | 1 | Adjusting Screw Spring |
| 10 | 46-07 | 1 | Adjuster Slot Plug |
| *11 | 6-193 | 5 | Nut Washer Assembly |
| ns | 54-89 | 1 | Bleeder Screw (included with item 2) |

* Not included with complete brake assembly. Item sold separately.
ns - not shown

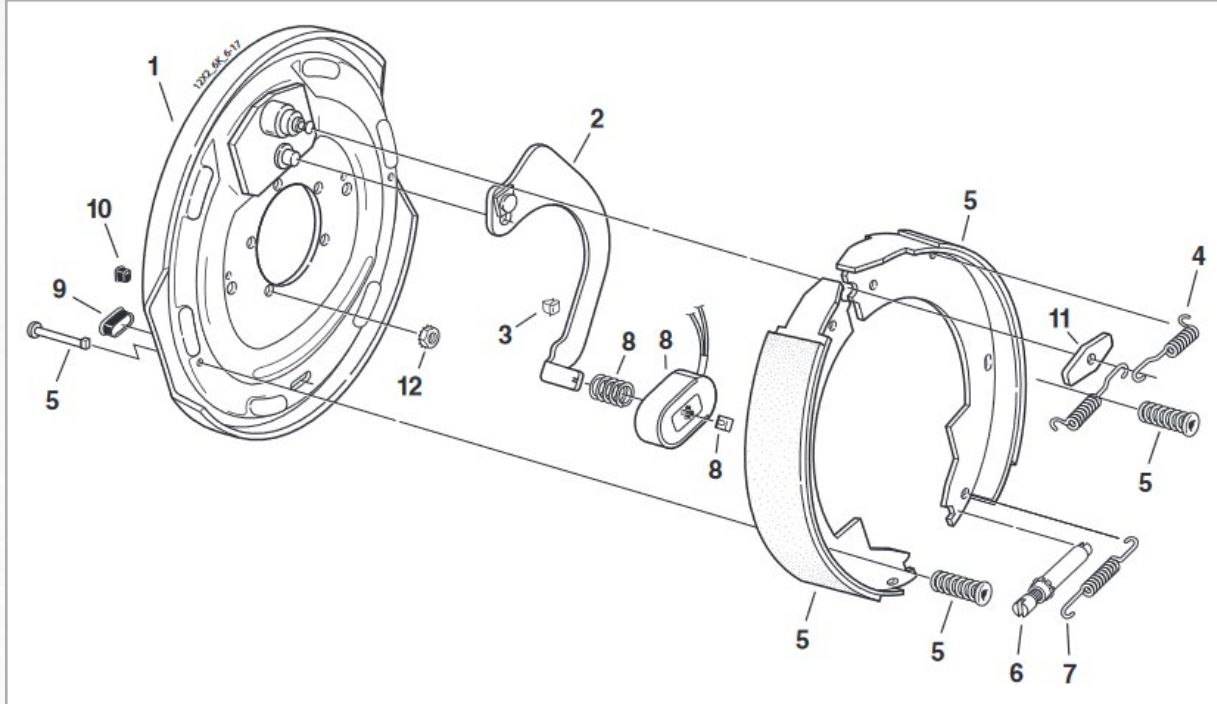

Electric Brake 6000# (CSA 6000#)

This brake is rated to a maximum capacity of 6000lbs / pair.

| Item | Part Number | Qty per Brake | Description |
|------|-------------|---------------|-------------------------------------------------------------------------------------------------------------------------------------------------------------------------------|
| 0 | K23-105 | 1 | LH Complete Brake Assembly (shown) |
| 0 | K23-106 | 1 | RH Complete Brake Assembly |
| 1 | 36-89-1 | 1 | Backing Plate Assembly |
| 2 | 47-107-5 | 1 | LH Actuating Lever Arm Assembly |
| 2 | 47-108-5 | 1 | RH Actuating Lever Arm Assembly |
| 3 | 27-05 | 2 | Wire Clip |
| 4 | 46-09 | 2 | Retractor Spring |
| 5 | K71-127 | 1 | Shoe & Lining Kit Contains: 1 #40-215 Primary Shoe & Lining 1 #40-216 Secondary Shoe & Lining 2 #49-11 Shoe Hold Down Pin #8 2 #46-77 Shoe Hold Down Spring & Cup |
| 6 | 43-4 | 1 | Adjuster Assembly |
| 7 | 46-18 | 1 | Adjusting Screw Spring |
| 8 | K71-105 | 1 | Magnet Kit Contains: 1 #42-149 Magnet (green wire) 1 #27-09 Magnet Clip 1 #46-80 Magnet Spring (before 7/16) 1 #46-175 Magnet Spring (after 7/16) |
| 9 | 46-07 | 2 | Adjuster Slot Plug |
| 10 | 46-16 | 1 | Wire Grommet |
| 11 | 5-67 | 1 | Anchor Post Washer |
| *12 | 6-193 | 5 | Nut Washer Assembly |

* Not included with complete brake assembly. Item sold separately.

5500 - 7000 LBS CAPACITY

12" x 2" 6K Nev-R-Adjust® Electric Brake

CSA approved at 6000#/14.2 SLR

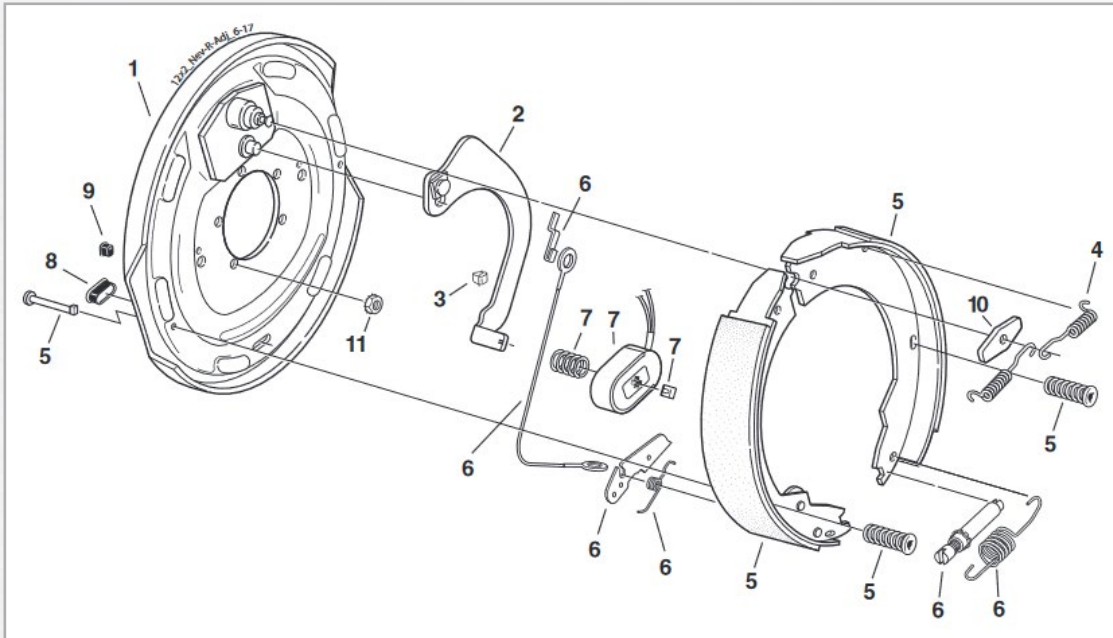

Electric Brake 6000# (CSA 6000#)

| Item | Part Number | Qty per Brake | Description |
|------|--------------|---------------|--------------------------------------------------------------------------------------------------------------------------------------------------------------------------------------------------------------------------------------------------------------------------------------------------------------------------------|
| 0 | K23-458 | 1 | LH Complete Brake Assembly (shown) |
| 0 | K23-459 | 1 | RH Complete Brake Assembly |
| 1 | 36-89-1 | 1 | Backing Plate Assembly |
| 2 | 47-107-5 | 1 | LH Actuating Lever Arm Assembly |
| 2 | 47-108-5 | 1 | RH Actuating Lever Arm Assembly |
| 3 | 27-05 | 2 | Wire Clip |
| 4 | 46-09 | 2 | Retractor Spring |
| 5 | K71-675 (LH) | 1 | LH Shoe & Lining Kit Contains: 1 #40-215 Primary Shoe & Lining 1 #40-216-1 Secondary Shoe & Lining 2 #49-11 Shoe Hold Down Pin #2 2 #46-77 Shoe Hold Down Spring & Cup |
| 5 | K71-676 (RH) | 1 | RH Shoe & Lining Kit Contains: 1 #40-215 Primary Shoe & Lining 1 #40-216-2 Secondary Shoe & Lining 2 #49-11 Shoe Hold Down Pin #2 2 #46-77 Shoe Hold Down Spring & Cup |
| 6 | K71-679 | 1 | LH & RH Brake Adjuster Kit Contains: 2 #46-139 Adjusting Screw Spring 1 #46-140 LH Lever Spring 1 #46-141 RH Lever Spring 1 #48-22 LH Adjuster Assembly 1 #48-23 RH Adjuster Assembly 2 #71-528 Adjuster Cable 2 #71-529 Hook for Cable 1 #71-53-1 LH Adjusting Lever 1 #71-53-2 RH Adjusting Lever |
| 7 | K71-105 | 1 | Magnet Kit Contains: 1 #42-149 Magnet (green wire) 1 #27-09 Magnet Clip 1 #46-80 Magnet Spring (before 7/16) 1 #46-175 Magnet Spring (after 7/16) |
| 8 | 46-07 | 2 | Adjuster Slot Plug |
| 9 | 46-16 | 1 | Wire Grommet |
| 10 | 5-67 | 1 | Anchor Post Washer |
| *11 | 6-193 | 5 | Nut Washer Assembly |

* Not included with complete brake assembly. Item sold separately.

BRAKES AND COMPONENTS

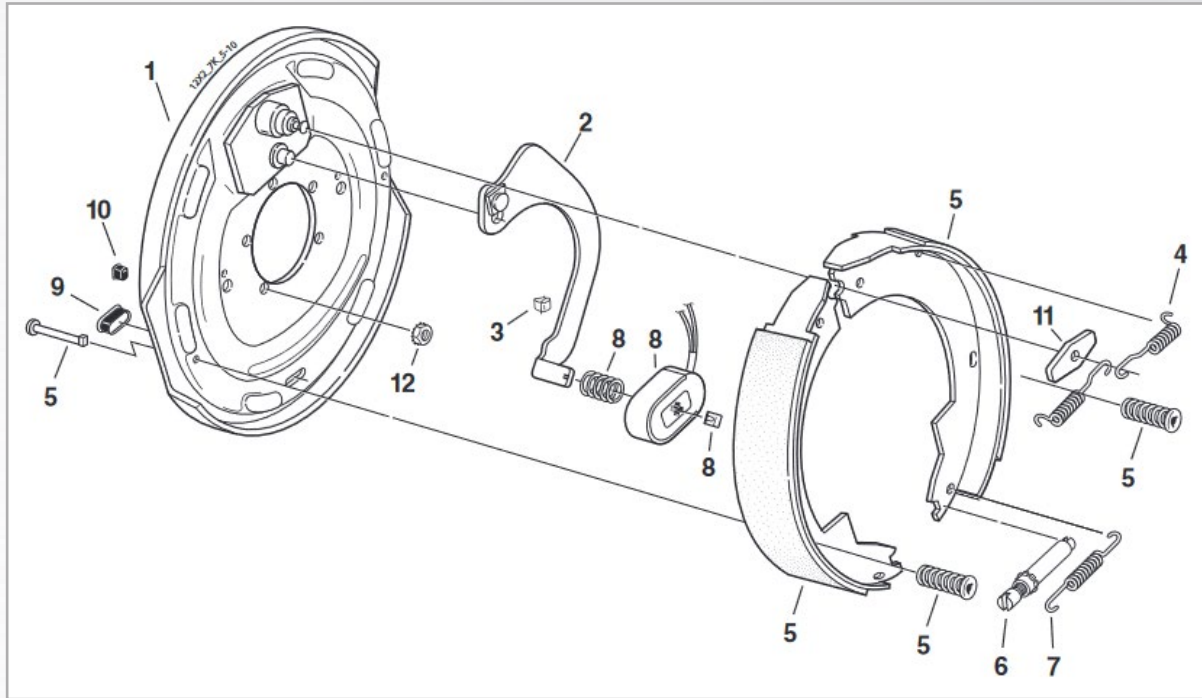

Electric Brake 7000#

| Item | Part Number | Qty per Brake | Description |
|------|-------------|---------------|-------------------------------------------------------------------------------------------------------------------------------------------------------------------------------|
| 0 | K23-180 | 1 | LH Complete Brake Assembly |
| 0 | K23-181 | 1 | RH Complete Brake Assembly (shown) |
| 1 | 36-89-1 | 1 | Backing Plate Assembly |
| 2 | 47-107-5 | 1 | LH Actuating Lever Arm Assembly |
| 2 | 47-108-5 | 1 | RH Actuating Lever Arm Assembly |
| 3 | 27-05 | 2 | Wire Clip |
| 4 | 46-09 | 2 | Retractor Spring |
| 5 | K71-127 | 1 | Shoe & Lining Kit Contains: 1 #40-215 Primary Shoe & Lining 1 #40-216 Secondary Shoe & Lining 2 #49-11 Shoe Hold Down Pin #2 2 #46-77 Shoe Hold Down Spring & Cup |
| 6 | 43-4 | 1 | Adjuster Assembly |
| 7 | 46-18 | 1 | Adjusting Screw Spring |
| 8 | K71-125 | 1 | Magnet Kit Contains: 1 #42-143 Magnet (green wire) 1 #27-09 Magnet Clip 1 #46-80 Magnet Spring (before 7/16) 1 #46-175 Magnet Spring (after 7/16) |
| 9 | 46-07 | 2 | Adjuster Slot Plug |
| 10 | 46-16 | 1 | Wire Grommet |
| 11 | 5-67 | 1 | Anchor Post Washer |
| *12 | 6-193 | 5 | Nut Washer Assembly |

* Not included with complete brake assembly. Item sold separately.

5500 - 7000 LBS CAPACITY

12" x 2" 7K Nev-R-Adjust® Electric Brake

CSA approved at 7000#/13.8 SLR

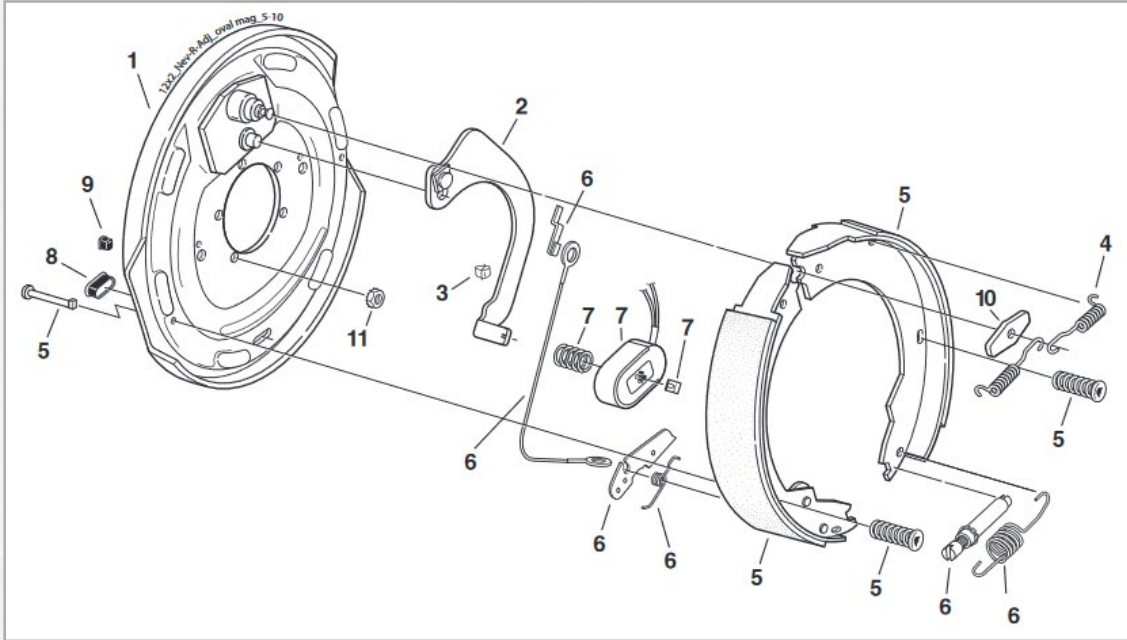

Electric Brake 7000#

| Item | Part Number | Qty per Brake | Description |
|------|--------------|---------------|--------------------------------------------------------------------------------------------------------------------------------------------------------------------------------------------------------------------------------------------------------------------------------------------------------------------------------|
| 0 | K23-458 | 1 | LH Complete Brake Assembly (shown) |
| 0 | K23-459 | 1 | RH Complete Brake Assembly |
| 1 | 36-89-1 | 1 | Backing Plate Assembly |
| 2 | 47-107-5 | 1 | LH Actuating Lever Arm Assembly |
| 2 | 47-108-5 | 1 | RH Actuating Lever Arm Assembly |
| 3 | 27-05 | 2 | Wire Clip |
| 4 | 46-09 | 2 | Retractor Spring |
| 5 | K71-675 (LH) | 1 | LH Shoe & Lining Kit Contains: 1 #40-215 Primary Shoe & Lining 1 #40-216-1 Secondary Shoe & Lining 2 #49-11 Shoe Hold Down Pin #2 2 #46-77 Shoe Hold Down Spring & Cup |
| 5 | K71-676 (RH) | 1 | RH Shoe & Lining Kit Contains: 1 #40-215 Primary Shoe & Lining 1 #40-216-2 Secondary Shoe & Lining 2 #49-11 Shoe Hold Down Pin #2 2 #46-77 Shoe Hold Down Spring & Cup |
| 6 | K71-679 | 1 | LH & RH Brake Adjuster Kit Contains: 2 #46-139 Adjusting Screw Spring 1 #46-140 LH Lever Spring 1 #46-141 RH Lever Spring 1 #48-22 LH Adjuster Assembly 1 #48-23 RH Adjuster Assembly 2 #71-528 Adjuster Cable 2 #71-529 Hook for Cable 1 #71-53-1 LH Adjusting Lever 1 #71-53-2 RH Adjusting Lever |
| 7 | K71-105 | 1 | Magnet Kit Contains: 1 #42-149 Magnet (green wire) 1 #27-09 Magnet Clip 1 #46-80 Magnet Spring (before 7/16) 1 #46-175 Magnet Spring (after 7/16) |
| 8 | 46-07 | 2 | Adjuster Slot Plug |
| 9 | 46-16 | 1 | Wire Grommet |
| 10 | 5-67 | 1 | Anchor Post Washer |
| *11 | 6-193 | 5 | Nut Washer Assembly |

* Not included with complete brake assembly. Item sold separately.

BRAKES AND COMPONENTS

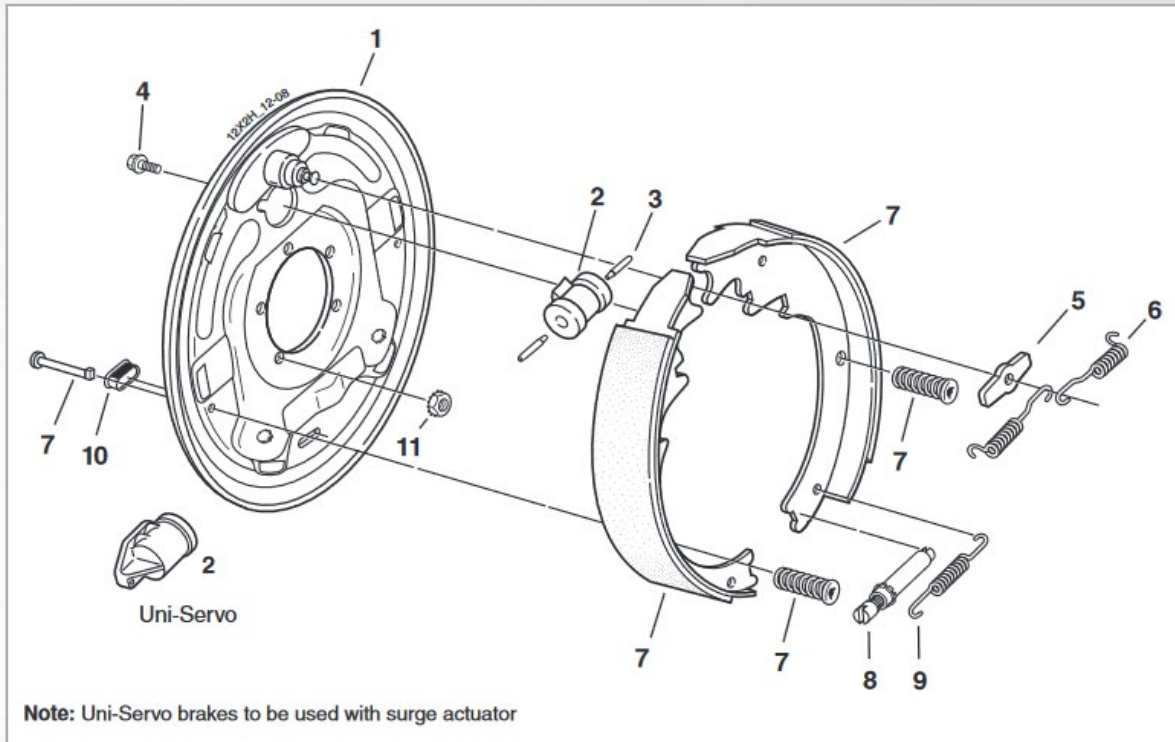

Hydraulic Brake 7000#

| Item | Part Number | Qty per Brake | Description |
|------|--------------|---------------|------------------------------------------------------------------------------------------------------------------------------------------------------------------------------------|
| 0 | K23-338 | 1 | LH Complete Brake Assembly - US |
| 0 | K23-339 | 1 | RH Complete Brake Assembly - US (shown) |
| 0 | K23-336 | 1 | LH Complete Brake Assembly - DS |
| 0 | K23-337 | 1 | RH Complete Brake Assembly - DS (shown) |
| 1 | 36-93-8 | 1 | Backing Plate Assembly |
| 2 | 54-64 | 1 | LH Brake Cylinder Uni-Servo |
| 2 | 54-65 | 1 | RH Brake Cylinder Uni-Servo |
| 2 | 54-62 | 1 | LH Brake Cylinder Duo-Servo |
| 2 | 54-63 | 1 | RH Brake Cylinder Duo-Servo |
| 3 | 54-60 | 1 or 2 | Cylinder Push Rod US (1) DS (2) |
| 4 | 87-01 | 2 | Sems (Screw & Washer Assembly) |
| 5 | 5-113 | 1 | Anchor Post Washer |
| 6 | 46-101 | 2 | Retractor Spring |
| 7 | K71-269 (LH) | 1 | LH Shoe & Lining Kit Contains: 1 #40-219 Primary Shoe & Lining 1 #40-218-2 Secondary Shoe & Lining 2 #49-12 Shoe Hold Down Pin #4 2 #46-77 Shoe Hold Down Spring & Cup |
| 7 | K71-27 (RH) | 1 | RH Shoe & Lining Kit Contains: 1 #40-219 Primary Shoe & Lining 1 #40-218-1 Secondary Shoe & Lining 2 #49-12 Shoe Hold Down Pin #4 2 #46-77 Shoe Hold Down Spring & Cup |
| 8 | 43-29 | 1 | Adjuster Assembly |
| 9 | 46-102 | 1 | Adjusting Screw Spring |
| 10 | 46-07 | 1 | Adjuster Slot Plug |
| *11 | 6-193 | 5 | Nut Washer Assembly |
| ns | 54-89 | 1 | Bleeder Screw (included with item 2) |

* Not included with complete brake assembly. Item sold separately.
ns - not shown

5500 - 7000 LBS CAPACITY Disc Brake for 7000 LB Axle



BRAKES AND COMPONENTS

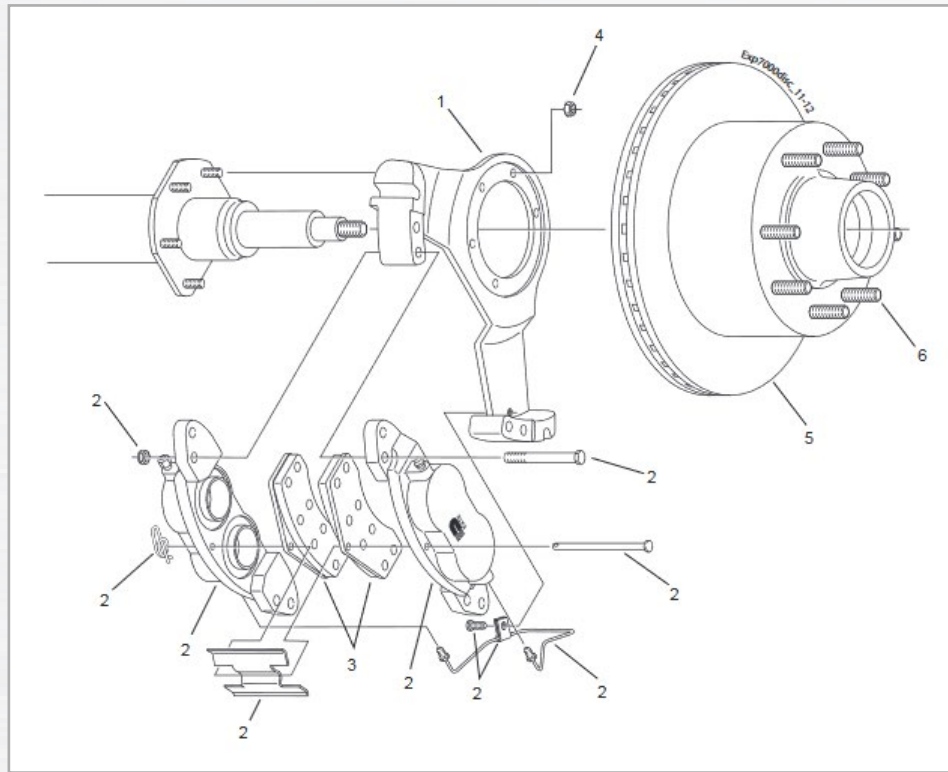

Disc Brake 7000#

| Item | Part No. | Qty per Brake | Description |
|------|-----------|---------------|----------------------------------------------|
| 1 | 90-8-1 | 1 | LH Anchor Yoke |
| 1 | 90-8-2 | 1 | RH Anchor Yoke (shown) |
| 2 | K71-693 | 1 | Caliper Assembly Kit for LH or RH Contains: |
| | 4 #6-45 | | Caliper Mounting Nut |
| | 4 #7-254 | | Caliper Mounting Bolt |
| | 1 #19-19 | | Cotter Ring |
| | 1 #27-06 | | Tube Clamp |
| | 1 #46-145 | | Anti-Rattle Spring |
| | 1 #54-92 | | Bleeder Screw |
| | 1 #54-94 | | Adapter Fitting |
| | 1 #56-38 | | Pad Retaining Pin |
| | 1 #71-517 | | Cross Over Hydraulic Line (yokes with notch) |
| | 1 #87-02 | | Hex Bolt |
| | 2 #89-5-6 | | Assembled Caliper Half |
| 3 | K71-629 | 1 | Brake Pad Kit (axle set) |
| 4 | 6-193 | 1 | 3/8" Brake Mounting Nut-Washer Assembly |

Disc Brake Hubs & Studs

| Item | Part No. | Qty per Brake | Description |
|------|----------|---------------|-------------------------------|
| 5 | 8-416-1 | 1 | Grease 1/2" Studs 8 on 6.50 |
| | 8-416-11 | 1 | Oil 1/2" Studs 8 on 6.50 |
| | 8-416-12 | 1 | Grease 3/8" Studs 8 on 6.50 |
| | 8-416-13 | 1 | Oil 3/8" Studs 8 on 6.50 |
| | 8-416-14 | 1 | Grease 5/8" Studs 8 on 6.50 |
| | 8-416-15 | 1 | Oil 5/8" Studs 8 on 6.50 |
| 6 | 7-122 | 8 | 1/2-20 x 1.84" Press-In Stud |
| | 7-223 | 8 | 3/16-18 x 2.01" Press-In Stud |
| | 7-224 | 8 | 5/8-18 x 2.50" Press-In Stud |

7200 LBS CAPACITY

12 1/4" x 2 1/2" Electric Brake - Cast Backing Plate

CSA approved at 7100#/14.2 SLR

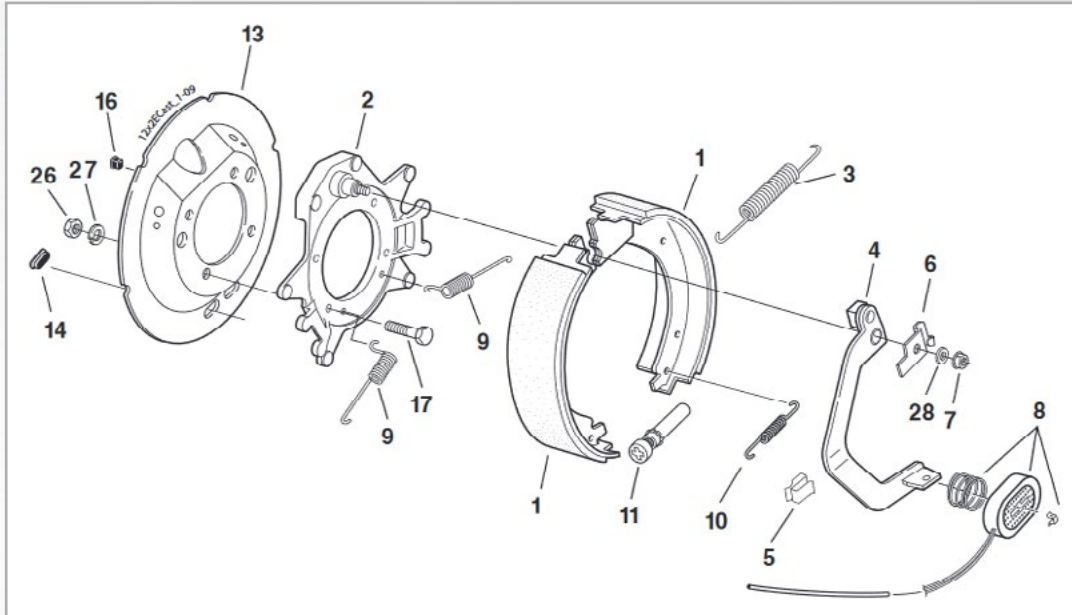

Electric Brake

Brakes manufactured after May 2000 use the cast backing plate.

| Item | Part Number | Qty per Brake | Description |
|------|-------------|---------------|-----------------------------------------------------------------------------------------------------------------------------|
| 0 | K23-428 | 1 | LH Complete Brake Assembly (shown) |
| 0 | K23-429 | 1 | RH Complete Brake Assembly |
| 1 | K71-497 | 1 | LH Shoe & Lining Kit Contains: 1 #40-348-1 Primary Shoe & Lining 1 #40-349-2 Secondary Shoe & Lining |
| 1 | K71-496 | 1 | RH Shoe & Lining Kit Contains: 1 #40-349-1 Primary Shoe & Lining 1 #40-348-2 Secondary Shoe & Lining |
| 2 | 36-119-2 | 1 | Backing Plate |
| 3 | 46-119 | 1 | Shoe Return (gray) |
| 4 | 47-124-5 | 1 | LH Actuating Lever Arm Assembly |
| 4 | 47-125-5 | 1 | RH Actuating Lever Arm Assembly |
| 5 | 27-39 | 3 | Wire Clip |
| 6 | 71-455-1 | 1 | LH Lever Arm Retainer |
| 6 | 71-455-2 | 1 | RH Lever Arm Retainer |
| 7 | 6-92-1 | 1 | Flange Nut |
| 8 | K71-378 | 1 | Magnet Kit Contains: 1 #42-131 Magnet (red/black wire after 6/17) 1 #27-05 Magnet Retainer 1 #46-117 Magnet Spring |
| 9 | 46-136 | 2 | Centering Spring |
| 10 | 46-18 | 1 | Adjuster Spring (red) |
| 11 | 48-17 | 1 | Adjuster Assembly |
| *13 | 36-118-2 | 1 | Dust Shield (sold separately) |
| *14 | 46-07 | 2 | Adjuster Slot Plug |
| *16 | 46-16 | 1 | Magnet Wire Grommet |
| *17 | 7-251 | 4 | Brake Mounting Bolt |
| *26 | 6-129 | 4 | Hex Nut |
| *27 | 5-58 | 4 | Lock Washer |
| 28 | 5-142 | 1 | Washer |

* Not included with complete brake assembly. Item sold separately.

7200 LBS CAPACITY

12 1/4" x 2 1/2" Electric Brake - Stamped Backing Plate

Service Parts Only

CSA approved at 7100#/14.2 SLR

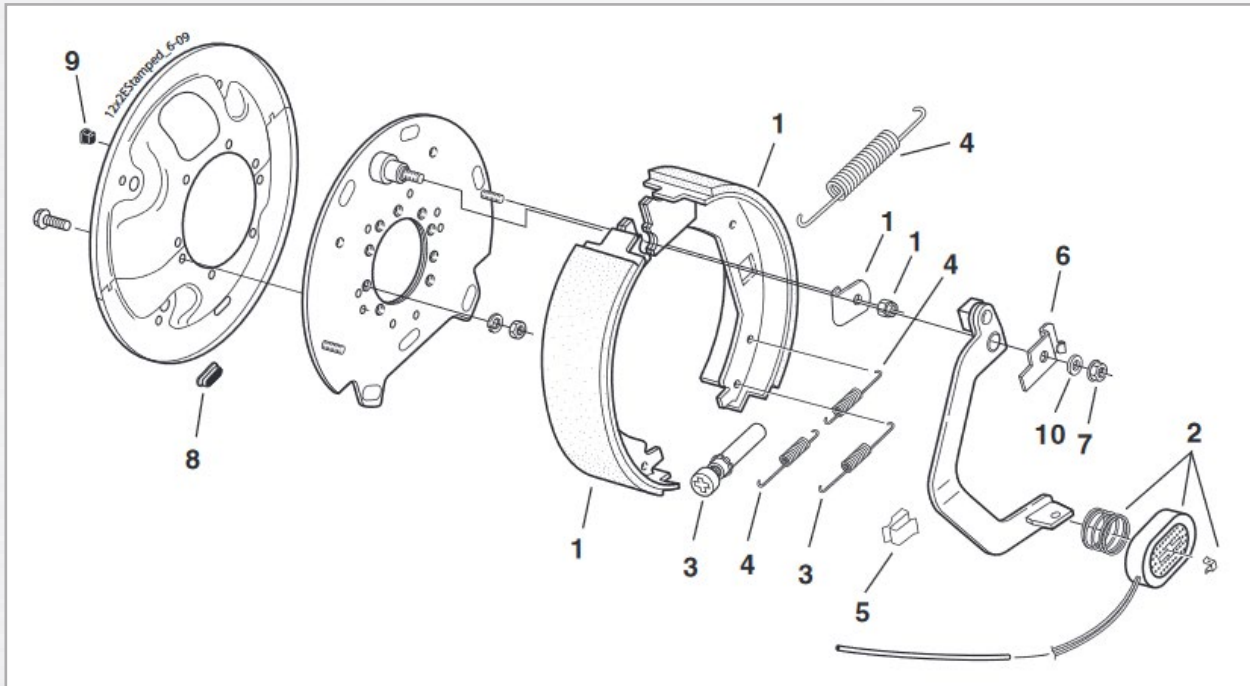

Electric Brake - Service Parts Only

| Item | Part Number | Qty per Brake | Description |
|------|-------------|---------------|--------------------------------------------------------------------------------------------------------------------------------------------------------------------------------------|
| 0 | 23-370 | 1 | LH Complete Brake Assembly (obsolete - no longer available) |
| 0 | 23-369 | 1 | RH Complete Brake Assembly (obsolete - no longer available) |
| 1 | K71-41 | 1 | Shoe & Lining Kit Contains: 1 #40-31-1 RH Primary S&L or LH Secondary S&L 1 #40-309-1 LH Primary S&L or RH Secondary S&L 2 #5-107 Shoe Hold Down Washer 2 #6-127 Locknut |
| 2 | K71-378 | 1 | Magnet Kit Contains: 1 #42-131 Magnet (red/black wire after 6/17) 1 #27-05 Magnet Retainer 1 #46-117 Magnet Spring |
| 3 | K71-411 | 1 | Adjusting Screw Kit Contains: 1 #46-18 Adjuster Spring (red) 1 #46-17 Adjuster Assembly |
| 4 | K71-412 | 1 | Brake Spring Kit Contains: 1 #46-119 Shoe Return (gray) 1 #46-117 Magnet Spring 2 #46-12 Centering Spring 1 #46-18 Adjuster Spring (red) |
| 5 | 27-39 | 3 | Wire Clip |
| 6 | 71-455-1 | 1 | LH Lever Arm Retainer |
| 6 | 71-455-2 | 1 | RH Lever Arm Retainer |
| 7 | 6-92-1 | 1 | Flange Nut |
| 8 | 46-07 | 2 | Adjuster Slot Plug |
| 9 | 46-16 | 1 | Magnet Wire Grommet |
| 10 | 5-142 | 1 | Washer |

Note: Only numbered items are available.

Brakes manufactured before May 2000 use the stamped backing plate.

BRAKES AND COMPONENTS

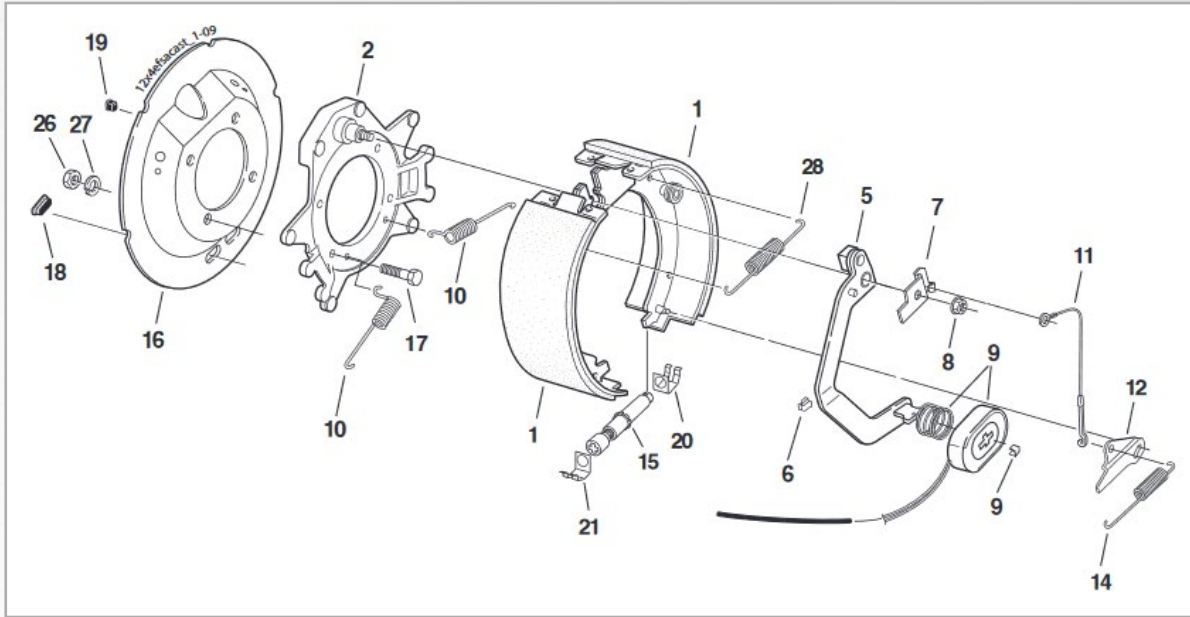

Electric Brake

Brakes manufactured after April 2000 use the cast backing plate (not shown)

| Item | Part Number | Qty per Brake | Description |
|------|-------------|---------------|----------------------------------------------------------------------------------------------------------------------------------|
| 0 | K23-434 | 1 | LH Complete Brake Assembly (shown) |
| 0 | K23-435 | 1 | RH Complete Brake Assembly |
| 1 | K71-499 | 1 | LH Shoe & Lining Kit Contains: 1 #40-35-1 Primary Shoe & Lining 1 #40-35-2 Secondary Shoe & Lining |
| 1 | K71-498 | 1 | RH Shoe & Lining Kit Contains: 1 #40-35-1 Primary Shoe & Lining 1 #40-35-2 Secondary Shoe & Lining |
| 2 | 36-119-2 | 1 | Backing Plate Assembly |
| 5 | 47-123-38 | 1 | LH Actuating Arm Assembly |
| 5 | 47-123-37 | 1 | RH Actuating Arm Assembly |
| 6 | 27-39 | 3 | Wire Clip |
| 7 | 71-455-1 | 1 | LH Arm/Shoe Retainer |
| 7 | 71-455-2 | 1 | RH Arm/Shoe Retainer |
| 8 | 6-92-1 | 1 | Flange Nut |
| 9 | K71-378 | 1 | Magnet Kit Contains: 1 #42-131 Magnet (red/black wire after 6/17) 1 #27-05 Magnet Retainer Clip 1 #46-117 Magnet Spring |
| 10 | 46-136 | 2 | Centering Spring |
| 11 | 71-462 | 1 | Adjuster Cable |
| 12 | 71-464 | 1 | LH Adjuster Lever |
| 12 | 71-463 | 1 | RH Adjuster Lever |
| 14 | 46-137 | 1 | Adjuster Spring |
| 15 | 48-19 | 1 | LH Adjuster Assembly (silver) |
| 15 | 48-20 | 1 | RH Adjuster Assembly (gold) |
| *16 | 36-115-2 | 1 | Dust Shield |
| *17 | 7-97 | 4 | Brake Mounting Bolt |
| *18 | 46-07 | 2 | Adjuster Slot Plug |
| *19 | 46-16 | 1 | Wire Grommet |
| 20 | 46-133 | 1 | Adjuster Clip (barrel end) |
| 21 | 46-132 | 1 | Adjuster Clip (thread end) |
| *26 | 6-129 | 4 | Brake Mounting Nut |
| *27 | 5-58 | 4 | Lock Washer |
| 28 | 46-119 | 1 | Return Spring |

* Not included with complete brake assembly. Item sold separately.

8000 LBS CAPACITY 12 1/4" x 3 3/8" 8K Hydraulic Brake FSA

ABS Parts Available

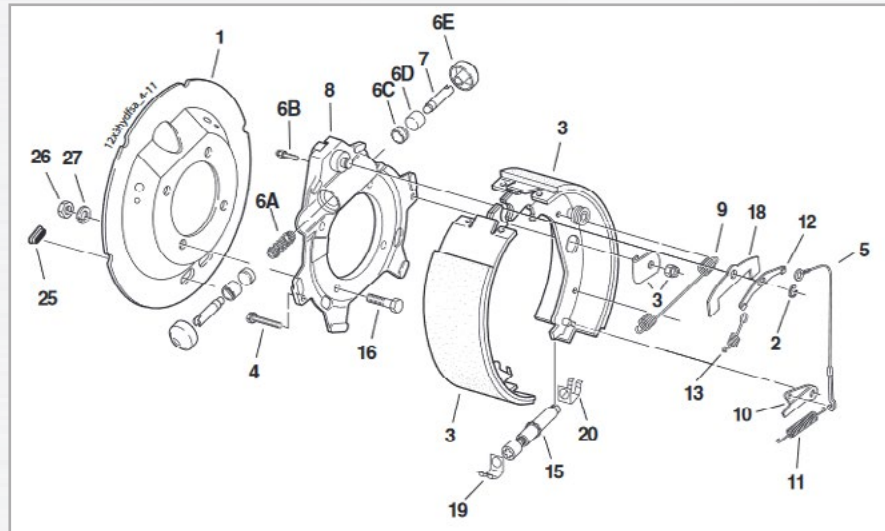

Hydraulic Brake

Hydraulic Brake - Corrosion Resistant Duo-Servo Only

BRAKES AND COMPONENTS

| Item | Part No. | Qty per Brake | Description |
|------|----------|---------------|-----------------------------------------------------------------------------------------------------------------------------------------------------------------|
| +0 | K23-418 | 1 | LH Complete Brake Assembly FSA US |
| +0 | K23-419 | 1 | RH Complete Brake Assembly FSA US |
| 0 | K23-402 | 1 | LH Complete Brake Assembly FSA DS (shown) |
| 0 | K23-403 | 1 | RH Complete Brake Assembly FSA DS |
| *1 | 36-115-2 | 1 | Dust Shield |
| 2 | 69-53 | 1 | Retainer |
| 3 | K71-165 | 1 | LH Shoe & Lining Kit Contains: 1 #40-199-1 Primary Shoe & Lining 1 #40-199-2 Secondary Shoe & Lining 2 #5-107 Shoe Hold Down Washer 2 #6-86 Locknut |
| 3 | K71-166 | 1 | RH Shoe & Lining Kit Contains: 1 #40-2-1 Primary Shoe & Lining 1 #40-2-2 Secondary Shoe & Lining 2 #5-107 Shoe Hold Down Washer 2 #6-86 Locknut |
| 4 | 7-113 | 2 | Shoe Hold Down Screw |
| 5 | 71-462 | 1 | Adjuster Cable |
| 6 | K71-08 | 1 | Wheel Cylinder Kit (1.00" Bore) Contains: 1 #46-13 Spring 2 #54-32 Boot 2 #54-41 Piston 2 #54-85 Cup 1 #54-35 Bleeder Screw |
| 7 | 54-33 | 1 or 2 | Cylinder Push Rod US (1) DS (2) |
| 8 | 36-64-6 | 1 | LH Spider Assembly US (includes items 4, 6, 7) |
| 8 | 36-64-7 | 1 | RH Spider Assembly US (includes items 4, 6, 7) |
| 8 | 36-64-3 | 1 | Spider Assembly (includes items 4, 6, 7) DS |
| 9 | 46-87 | 1 | Retractor Spring |
| 10 | 71-464 | 1 | LH Adjuster Lever |
| 10 | 71-463 | 1 | RH Adjuster Lever |
| 11 | 46-135 | 1 | LH Adjuster Spring |
| 11 | 46-134 | 1 | RH Adjuster Spring |
| 12 | 71-456 | 1 | Cable Attachment Bracket |
| 13 | 46-131-1 | 1 | Extension Spring |
| 15 | 48-19 | 1 | LH Adjuster Assembly |
| 15 | 48-02 | 1 | RH Adjuster Assembly |
| *16 | 7-97 | 4 | Brake Mounting Bolt |
| 18 | 34-62 | 1 | Piston Stop |
| 19 | 46-132 | 1 | Adjuster Clip (thread end) |
| 20 | 46-133 | 1 | Adjuster Clip (barrel end) |
| *25 | 46-07 | 2 | Adjuster Slot Plug |
| *26 | 6-129 | 4 | Brake Mounting Nut |
| *27 | 5-58 | 4 | Lock Washer |

| Item | Part No. | Qty per Brake | Description |
|------|----------|---------------|-------------------------------------------------------------------------------------------------------------------------------------------------------------------|
| 0 | K23-420 | 1 | LH Complete Brake Assembly FSA |
| 0 | K23-421 | 1 | RH Complete Brake Assembly FSA |
| *1 | 36-115-2 | 1 | Dust Shield |
| 2 | 69-53 | 1 | Retainer |
| 3 | K71-437 | 1 | LH Shoe & Lining Kit Contains: 1 #40-199-5 Primary Shoe & Lining 1 #40-199-6 Secondary Shoe & Lining 2 #5-107-2 Shoe Hold Down Washer 2 #6-86 Locknut |
| 3 | K71-438 | 1 | RH Shoe & Lining Kit Contains: 1 #40-2-5 Primary Shoe & Lining 1 #40-2-6 Secondary Shoe & Lining 2 #5-107-2 Shoe Hold Down Washer 2 #6-86 Locknut |
| 4 | 7-113-1 | 2 | Shoe Hold Down Screw |
| 5 | 71-462 | 1 | Adjuster Cable |
| 6A | 46-130 | 1 | Spring |
| 6B | 54-35 | 1 | Bleeder Screw |
| 6C | 54-85 | 2 | Cup |
| 6D | 54-83 | 2 | Piston |
| 6E | 54-32 | 2 | Boot |
| 7 | 54-33 | 2 | Cylinder Push Rod |
| 8 | 36-64-14 | 1 | Spider Assembly (includes items 4, 6, 7) DS |
| 9 | 46-87-1 | 1 | Retractor Spring |
| 10 | 71-464 | 1 | LH Adjuster Lever |
| 10 | 71-463 | 1 | RH Adjuster Lever |
| 11 | 46-135-1 | 1 | LH Adjuster Spring |
| 11 | 46-134-1 | 1 | RH Adjuster Spring |
| 12 | 71-456 | 1 | Cable Attachment Bracket |
| 13 | 46-131-2 | 1 | Extension Spring |
| 15 | 48-19 | 1 | LH Adjuster Assembly |
| 15 | 48-02 | 1 | RH Adjuster Assembly |
| *16 | 7-97 | 4 | Brake Mounting Bolt |
| 18 | 34-62-2 | 1 | Piston Stop |
| 19 | 46-132 | 1 | Adjuster Clip (thread end) |
| 20 | 46-133 | 1 | Adjuster Clip (barrel end) |
| *25 | 46-07 | 2 | Adjuster Slot Plug |
| *26 | 6-129 | 4 | Brake Mounting Nut |
| *27 | 5-58 | 4 | Lock Washer |

* Not included with complete brake assembly. Item sold separately.
+ Uni-Servo version not shown

* Not included with complete brake assembly. Item sold separately.

8000 LBS CAPACITY Disc Brake for 8000 LB Axles

CSA approved at 8000#/14.2 SLR

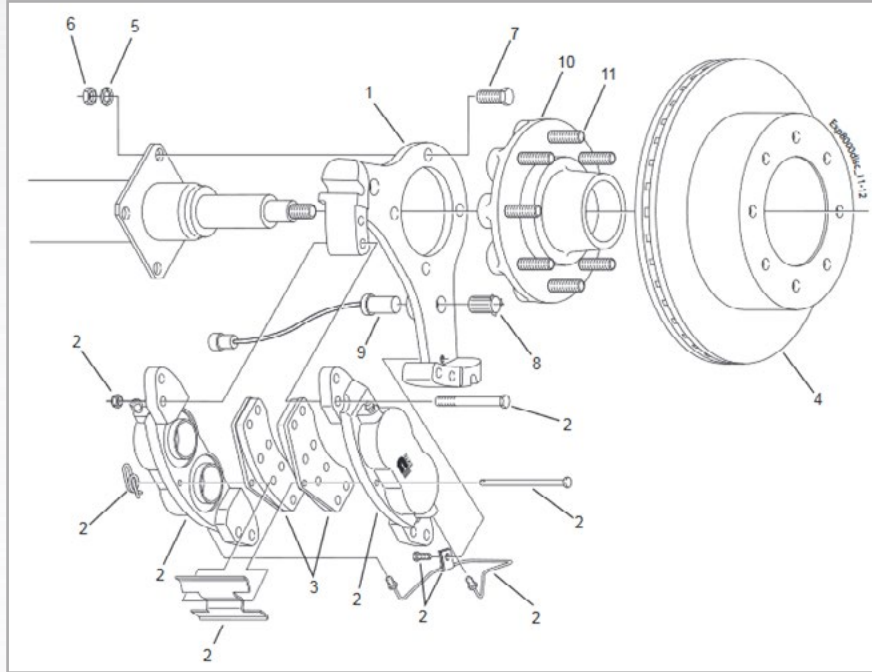

Disc Brake 8000#

| Item | Part No. | Qty per Brake | Description |
|------|-----------|---------------|-------------------------------------------------|
| 1 | 90-3-1 | 1 | Anchor Yoke |
| 2 | K71-630 | 1 | Caliper Assembly Kit for LH or RH Contains: |
| | 4 #6-45 | | Caliper Mounting Nut |
| | 4 #7-254 | | Caliper Mounting Bolt |
| | 1 #19-19 | | Cotter Ring |
| | 1 #27-06 | | Tube Clamp |
| | 1 #46-145 | | Anti-Rattle Spring |
| | 1 #54-92 | | Bleeder Screw |
| | 1 #54-94 | | Adapter Fitting |
| | 1 #56-38 | | Pad Retaining Pin |
| | 1 #71-513 | | Cross Over Hydraulic Line (yokes without notch) |
| | 1 #71-518 | | Cross Over Hydraulic Line (yokes with notch) |
| | 1 #87-02 | | Hex Bolt |
| | 2 #89-3-2 | | Assembled Caliper Half |
| 3 | K71-629 | 1 | Brake Pad Kit (axle set) |
| 4 | K71-631 | 1 | Rotor Kit |
| 5 | 5-58 | 4 | 1/2" Lock Washer |
| 6 | 6-129 | 4 | 1/2" Hex Nut |
| 7 | 7-97 | 4 | 1/2" Brake Mounting Bolt |
| 8 | 97-02 | 1 | ABS Sensor Retaining Clip |
| 9 | 97-04 | 1 | ABS Sensor (straight) |

Disc Brake Hubs & Studs

| Item | Part No. | Qty per Brake | Description |
|------|----------|---------------|-------------------------------|
| 10 | 8-399-5 | 1 | Grease 3/16" Studs 8 on 6.50 |
| 10 | 8-399-6 | 1 | Oil 3/16" Studs 8 on 6.50 |
| 10 | 8-399-7 | 1 | Grease 5/8" Studs 8 on 6.50 |
| 10 | 8-399-8 | 1 | Oil 5/8" Studs 8 on 6.50 |
| 11 | 7-257 | 8 | 3/16-18 x 2.50" Press-In Stud |
| 11 | 7-115 | 8 | 3/16-18 x 3.16" Press-In Stud |

Disc Brake 8000# with 50mm Nev-R-Lube®

| Item | Part No. | Qty per Brake | Description |
|------|-----------|---------------|-------------------------------------------------|
| 1 | 90-7-1 | 1 | Anchor Yoke |
| 2 | K71-630 | 1 | Caliper Assembly Kit for LH or RH Contains: |
| | 4 #6-45 | | Caliper Mounting Nut |
| | 4 #7-254 | | Caliper Mounting Bolt |
| | 1 #19-19 | | Cotter Ring |
| | 1 #27-06 | | Tube Clamp |
| | 1 #46-145 | | Anti-Rattle Spring |
| | 1 #54-92 | | Bleeder Screw |
| | 1 #54-94 | | Adapter Fitting |
| | 1 #56-38 | | Pad Retaining Pin |
| | 1 #71-513 | | Cross Over Hydraulic Line (yokes without notch) |
| | 1 #71-518 | | Cross Over Hydraulic Line (yokes with notch) |
| | 1 #87-02 | | Hex Bolt |
| | 2 #89-3-2 | | Assembled Caliper Half |
| 3 | K71-629 | 1 | Brake Pad Kit (axle set) |
| 4 | K71-631 | 1 | Rotor Kit |
| 5 | 5-58 | 4 | 1/2" Lock Washer |
| 6 | 6-129 | 4 | 1/2" Hex Nut |
| 7 | 7-97 | 4 | 1/2" Brake Mounting Bolt |
| 8 | 97-02 | 1 | ABS Sensor Retaining Clip |
| 9 | 97-04 | 1 | ABS Sensor (straight) |

Nev-R-Lube® Disc Brake Hubs

| Item | Part No. | Qty per Brake | Description |
|------|----------|---------------|-------------------------------|
| 10 | 8-402-8 | 1 | 3/16" Studs, 50mm 8 on 6.50 |
| 10 | 8-402-81 | 1 | 5/8" Studs, 50mm 8 on 6.50 |
| 11 | 7-257 | 8 | 3/16-18 x 2.50" Press-In Stud |
| 11 | 7-115 | 8 | 3/16-18 x 3.16" Press-In Stud |

Electric Brake

Electric Brake Parts - Cast Backing Plate

After April 2000

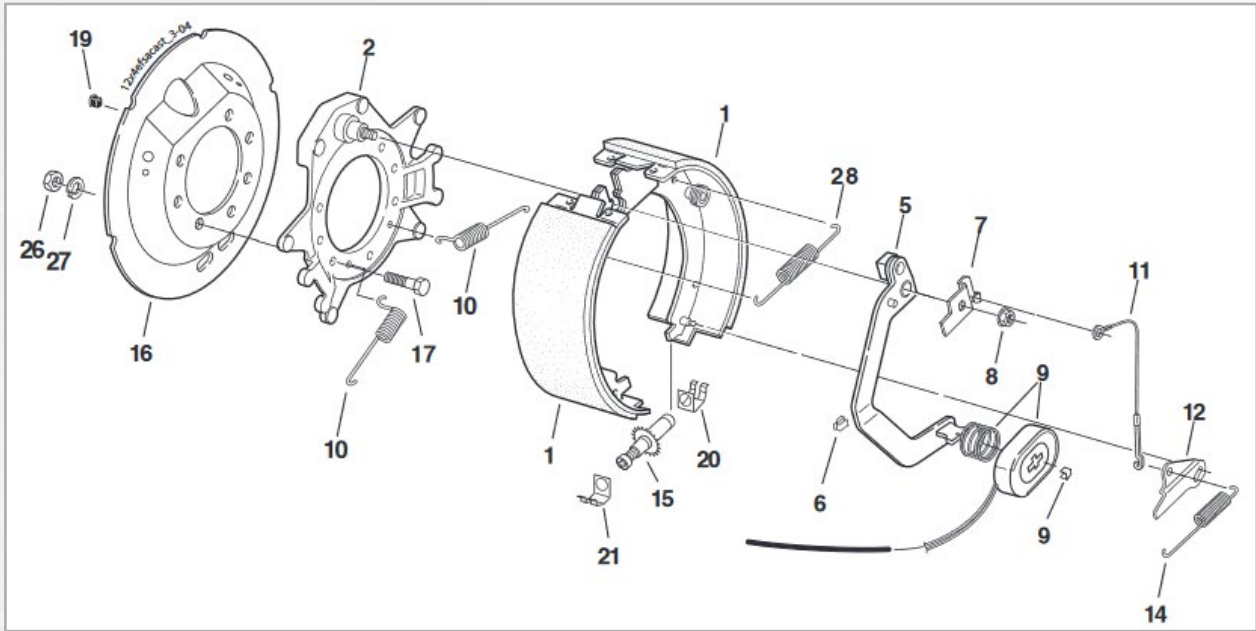

BRAKES AND COMPONENTS

| Item | Description | Qty per Brake | 12 1/4" x 3 3/8" 9K, 10K GD, #13G Part Number | 12 1/4" x 4" 10K, #13D Part Number | 12 1/4" x 5" 12K Part Number | 12 1/4" x 5" 15K Part Number |
|------|--------------------------------|---------------|-----------------------------------------------------|------------------------------------------|------------------------------------|------------------------------------|
| 1 | LH Shoe & Lining Kit Contains: | 1 | K71-499 | K71-501 | K71-503 | K71-503 |
| | LH Primary | 1 | 4-35-1 | 4-352-1 | 4-354-1 | 4-354-1 |
| | LH Secondary | 1 | 4-351-2 | 4-353-2 | 4-355-2 | 4-355-2 |
| 1 | RH Shoe & Lining Kit Contains: | 1 | K71-498 | K71-500 | K71-502 | K71-502 |
| | RH Primary | 1 | 4-351-1 | 4-353-1 | 4-355-1 | 4-355-1 |
| | RH Secondary | 1 | 4-35-2 | 4-352-2 | 4-354-2 | 4-354-2 |
| 2 | Backing Plate Assembly | 1 | 36-12-2 | 36-12-2 | 36-12-2 | 36-12-2 |
| 5 | LH Actuator Arm Assembly | 1 | 47-123-38 | 47-123-38 | 47-123-36 | 47-123-36 |
| | RH Actuator Arm Assembly | 1 | 47-123-37 | 47-123-37 | 47-123-35 | 47-123-35 |
| 6 | Wire Clip | 3 | 27-39 | 27-39 | 27-39 | 27-39 |
| 7 | LH Arm/Shoe Retainer | 1 | 71-455-1 | 71-455-1 | 71-455-1 | 71-455-1 |
| | RH Arm/She Retainer | 1 | 71-455-2 | 71-455-2 | 71-455-2 | 71-455-2 |
| 8 | Flange Nut | 1 | 6-92-1 | 6-92-1 | 6-92-1 | 6-92-1 |
| 9 | Magnet Kit Contains: | 1 | K71-378 | K71-378 | K71-378 | K71-378 |
| | Magnet Retainer Clip | 1 | 27-5 | 27-5 | 27-5 | 27-5 |
| | Magnet Assembly | 1 | 42-131 | 42-131 | 42-131 | 42-131 |
| | Magnet Mounting Spring | 1 | 46-117 | 46-117 | 46-117 | 46-117 |
| 10 | Centering Spring | 2 | 46-136 | 46-136 | 46-136 | 46-136 |
| 11 | Adjuster Cable | 1 | 71-462 | 71-462 | 71-462 | 71-462 |
| 12 | LH Adjuster Lever | 1 | 71-464 | 71-464 | 71-464 | 71-464 |
| | RH Adjuster Lever | 1 | 71-463 | 71-463 | 71-463 | 71-463 |
| 14 | Adjuster Spring | 1 | 46-137 | 46-137 | 46-137 | 46-137 |
| 15 | LH Adjuster Assembly | 1 | 48-19 | 48-19 | 48-19 | 48-19 |
| | RH Adjuster Assembly | 1 | 48-20 | 48-20 | 48-20 | 48-20 |
| 16 | Dust Shield | 1 | 36-115-21 | 36-115-22 | 36-115-23 | 36-115-23 |
| 17 | Brake Mounting Screw | 7 | 7-116 | 7-116 | 7-116 | 7-116 |
| 19 | Wire Grommet | 1 | 46-16 | 46-16 | 46-16 | 46-16 |
| 20 | Adjuster Clip (thread end) | 1 | 46-132 | 46-132 | 46-132 | 46-132 |
| 21 | Adjuster Clip (barrel end) | 1 | 46-133 | 46-133 | 46-133 | 46-133 |
| 26 | Brake Mounting Nut | 7 | 6-17 | 6-17 | 6-17 | 6-17 |
| 27 | Brake Mounting Lockwasher | 7 | 5-8 | 5-8 | 5-8 | 5-8 |
| 28 | Return Spring | 1 | 46-119 | 46-119 | 46-119 | 46-119 |

Electric Brake

Electric Brake Parts - Stamped Backing Plate

Before April 2000 Service Parts Only

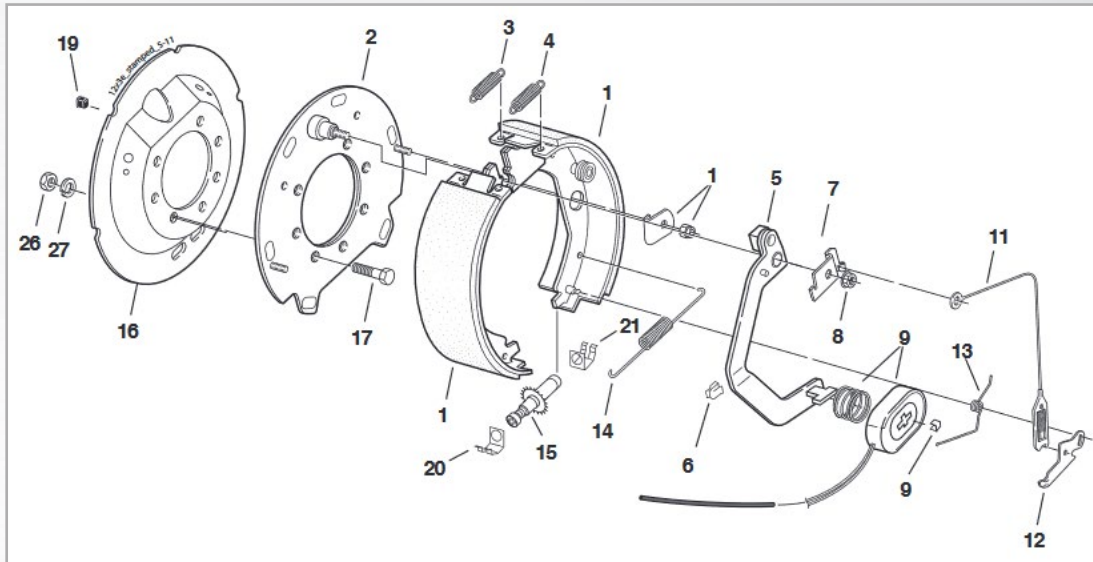

| Item | Description | Qty per Brake | 12 1/4" x 3 3/8" 9K, 10K GD, #13G Part Number | 12 1/4" x 4" 10K, #13D Part Number | 12 1/4" x 5" 12K Part Number | 12 1/4" x 5" 15K Part Number |
|------|------------------------------------|---------------|-----------------------------------------------------|------------------------------------------|------------------------------------|------------------------------------|
| 1 | LH Shoe & Lining Kit Contains: | 1 | K71-49 | K71-51 | K71-53 | K71-53 |
| | LH Primary | 1 | 4-11-1 | 4-108-1 | 4-102-1 | 4-102-1 |
| | LH Secondary | 1 | 4-111-2 | 4-109-2 | 4-103-2 | 4-103-2 |
| | Shoe Hold Down Washer | 2 | 5-107 | 5-107 | 5-107 | 5-107 |
| | Lock Nut | 2 | 6-127 | 6-127 | 6-127 | 6-127 |
| 1 | RH Shoe & Lining Kit Contains: | 1 | K71-50 | K71-52 | K71-54 | K71-54 |
| | RH Primary | 1 | 4-111-1 | 4-109-1 | 4-103-1 | 4-103-1 |
| | RH Secondary | 1 | 4-11-2 | 4-108-2 | 4-102-2 | 4-102-2 |
| | Shoe Hold Down Washer | 2 | 5-107 | 5-107 | 5-107 | 5-107 |
| | Lock But | 2 | 6-127 | 6-127 | 6-127 | 6-127 |
| 2 | Backing Plate Assembly (obsolete) | 1 | 36-72-5 | 336-72-5 | 36-72-6 | 36-72-6 |
| 3 | Shoe Return Spring (rear - black) | 1 | 46-71 | 46-71 | 46-71 | 46-71 |
| 4 | Shoe Return Spring (front - green) | 1 | 46-83 | 46-83 | 46-83 | 46-83 |
| 5 | LH Actuator Arm Assembly | 1 | 47-123-38 | 47-123-38 | 47-123-36 | 47-123-36 |
| | RH Actuator Arm Assembly | 1 | 47-123-37 | 47-123-37 | 47-123-35 | 47-123-35 |
| 6 | Wire Clip | 3 | 27-39 | 27-39 | 27-39 | 27-39 |
| 7 | LH Arm/Shoe Retainer | 1 | 71-455-1 | 71-455-1 | 71-455-1 | 71-455-1 |
| | RH Arm/She Retainer | 1 | 71-455-2 | 71-455-2 | 71-455-2 | 71-455-2 |
| 8 | Flange Nut | 1 | 6-92-1 | 6-92-1 | 6-92-1 | 6-92-1 |
| 9 | Magnet Kit Contains: | 1 | K71-378 | K71-378 | K71-378 | K71-378 |
| | Magnet Retainer Clip | 1 | 27-5 | 27-5 | 27-5 | 27-5 |
| | Magnet Assembly | 1 | 42-131 | 42-131 | 42-131 | 42-131 |
| | Magnet Mounting Spring | 1 | 46-117 | 46-117 | 46-117 | 46-117 |
| 11 | Adjuster Cable | 1 | 71-2 | 71-2 | 71-2 | 71-2 |
| 12 | LH Adjuster Lever | 1 | 71-19-1 | 71-19-1 | 71-19-1 | 71-19-1 |
| | RH Adjuster Lever | 1 | 71-19-2 | 71-19-2 | 71-19-2 | 71-19-2 |
| 13 | LH Adjuster Lever Spring | 1 | 46-73 | 46-73 | 46-73 | 46-73 |
| | RH Adjuster Lever Spring | 1 | 46-74 | 46-74 | 46-74 | 46-74 |
| 14 | Adjuster Spring | 1 | 46-72 | 46-72 | 46-72 | 46-72 |
| 15 | LH Adjuster Assembly | 1 | 48-9 | 48-9 | 48-9 | 48-9 |
| | RH Adjuster Assembly | 1 | 48-1 | 48-1 | 48-1 | 48-1 |
| 16 | Dust Shield | 1 | 36-115-21 | 36-115-22 | 36-115-23 | 36-115-23 |
| 17 | Brake Mounting Screw | 7 | 7-116 | 7-116 | 7-116 | 7-116 |
| 19 | Wire Grommet | 1 | 46-16 | 46-16 | 46-16 | 46-16 |
| 20 | Adjuster Clip (thread end) | 1 | 46-132 | 46-132 | 46-132 | 46-132 |
| 21 | Adjuster Clip (barrel end) | 1 | 46-133 | 46-133 | 46-133 | 46-133 |
| 26 | Brake Mounting Nut | 7 | 6-17 | 6-17 | 6-17 | 6-17 |
| 27 | Brake Mounting Lockwasher | 7 | 5-8 | 5-8 | 5-8 | 5-8 |

Electric Brake Forward Self-Adjusting Electric Brake

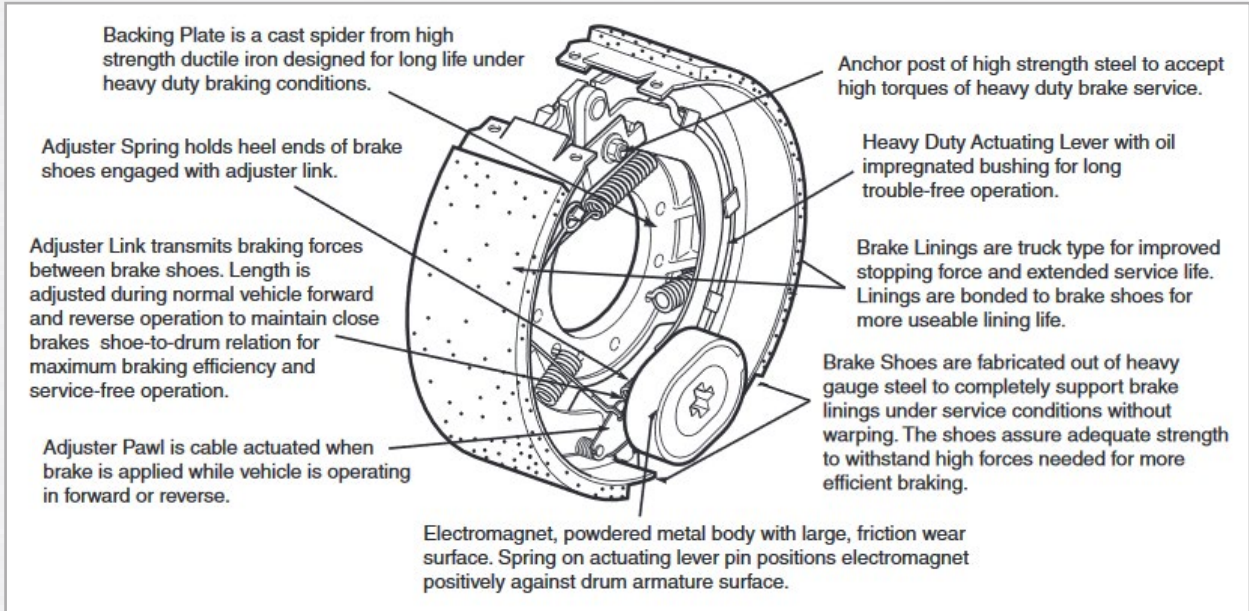

Electric Brake

| Size | Capacity | Part # LH | Part # RH |
|------------------|------------------|-----------|-----------|
| 12 1/4" x 3 3/8" | 9K, 10K GD, #13G | 23-450 | 23-451 |
| 12 1/4" x 4" | 10K, #13D | 23-438 | 23-439 |
| 12 1/4" x 5" | 12K | 23-442 | 23-443 |
| 12 1/4" x 5" | 15K | 23-446 | 23-447 |

Typical Electric Brake Wiring Diagram

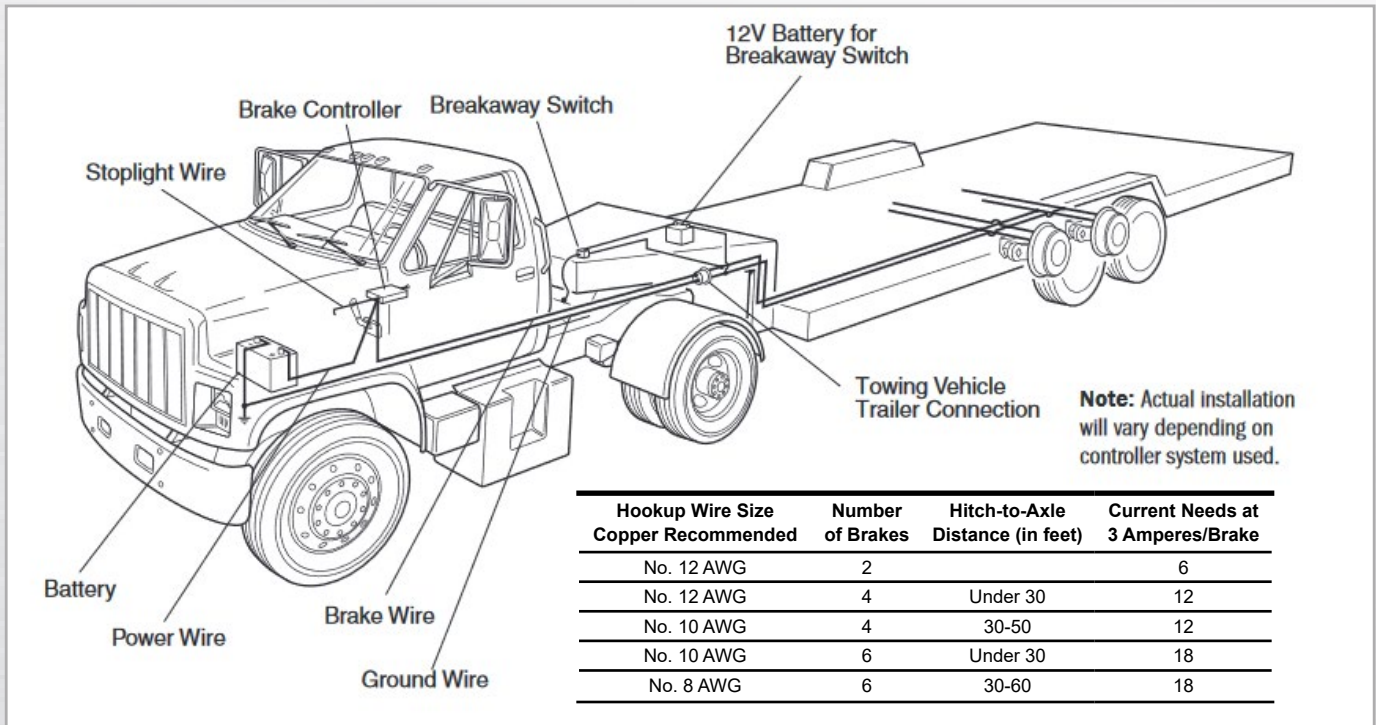

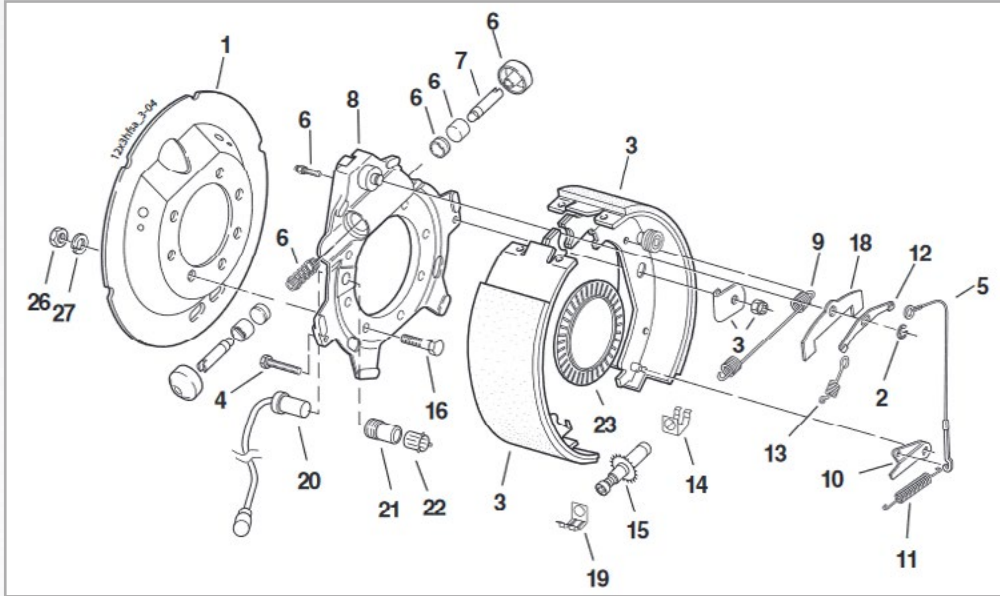

| Item | Description | Qty per Brake | 12 1/4" x 3 3/8" 9K, 10K GD, #13G Part Number | 12 1/4" x 4" 10K, #13D Part Number | 12 1/4" x 5" 12K Part Number | 12 1/4" x 5" 15K Part Number |
|----------------------------|----------------------------------|---------------|-----------------------------------------------------|------------------------------------------|------------------------------------|------------------------------------|
| 1 | Dust Cover | 1 | 36-115-21 | 36-115-22 | 36-115-23 | 36-115-23 |
| 2 | Retainer | 1 | 69-53 | 69-53 | 69-53 | 69-53 |
| 3 | LH Shoe & Lining Kit Contains: | 1 | K71-165 | K71-167 | K71-169 | K71-169 |
| | LH Primary | 1 | 40-199-1 | 40-197-1 | 40-195-1 | 40-195-1 |
| | LH Secondary | 1 | 40-199-2 | 40-197-2 | 40-192-2 | 40-195-2 |
| | Hold Down Washer | 2 | 5-107 | 5-107 | 5-107 | 5-107 |
| | Hold Down Locknut | 2 | 6-86 | 6-86 | 6-86 | 6-86 |
| 3 | RH Shoe & Lining Kit Contains: | 1 | K71-166 | K71-168 | K71-170 | K71-170 |
| | RH Primary | 1 | 40-200-1 | 40-198-1 | 40-196-1 | 40-196-1 |
| | RH Secondary | 1 | 40-200-2 | 40-198-2 | 40-196-2 | 40-196-2 |
| | Hold Down Washer | 2 | 5-107 | 5-107 | 5-107 | 5-107 |
| | Hold Down Locknut | 2 | 6-86 | 6-86 | 6-86 | 6-86 |
| 4 | Show Hold Down Screw | 2 | 7-113 | 7-113 | 7-113 | 7-113 |
| 5 | Adjuster Cable | 1 | 71-462 | 71-462 | 71-462 | 71-462 |
| 6 | Wheel Cylinder Kit Contains: | 1 | K71-81 | K71-81 | K71-81 | K71-81 |
| | Cylinder Spring | 1 | 46-128 | 46-128 | 46-128 | 46-129 |
| | Cylinder Boot | 2 | 54-32 | 54-32 | 54-32 | 54-32 |
| | Cylinder Piston | 2 | 54-38 | 54-38 | 54-38 | 54-30 |
| | Cylinder Cup | 2 | 54-86 | 54-86 | 54-86 | 54-87 |
| | Bleeder Screw | 1 | 54-35 | 54-35 | 54-35 | 54-35 |
| 7 | Cylinder Push Rod | 2 | 54-33 | 54-33 | 54-33 | 54-33 |
| 8 | Spider Assembly | 1 | 36-63-6 | 36-63-6 | 36-63-6 | 36-63-4 |
| 9 | Retractor Spring | 1 | 46-87 | 46-87 | 46-87 | 46-87 |
| 10 | LH Adjuster Lever | 1 | 71-464 | 71-464 | 71-464 | 71-464 |
| | RH Adjuster Lever | 1 | 71-463 | 71-463 | 71-463 | 71-463 |
| 11 | LH Adjuster Lever Spring (blue) | 1 | 46-135 | 46-135 | 46-135 | 46-135 |
| | RH Adjuster Lever Spring (black) | 1 | 46-134 | 46-134 | 46-134 | 46-134 |
| 12 | Cable Attachment Bracket FSA | 1 | 71-456 | 71-456 | 71-456 | 71-456 |
| 13 | Extension Spring | 1 | 46-131-1 | 46-131-1 | 46-131-1 | 46-131-1 |
| 14 | Adjuster Clip (barrel end) | 1 | 46-133 | 46-133 | 46-133 | 46-133 |
| 15 | LH Adjuster Assembly | 1 | 48-19 | 48-19 | 48-19 | 48-19 |
| | RH Adjuster Assembly | 1 | 48-20 | 48-20 | 48-20 | 48-20 |
| 16 | Brake Mounting Bolt | 7 | 7-116 | 7-116 | 7-116 | 7-116 |
| 18 | Piston Stop | 1 | 34-62 | 34-62 | 34-62 | 34-62 |
| 19 | Adjuster Clip (thread end) | 1 | 46-132 | 46-132 | 46-132 | 46-132 |
| 26 | Brake Mounting Nut | 7 | 6-17 | 6-17 | 6-17 | 6-17 |
| 27 | Lockwasher | 7 | 5-8 | 5-8 | 5-8 | 5-8 |
| Optional ABS Parts: | | | | | | |
| 20 | ABS Sensor (straight) | 1 | 97-4 | 97-4 | 97-4 | 97-4 |
| 21 | ABS Sensor Mounting Block | 1 | 24-204 | 24-204 | 24-204 | 24-204 |
| 22 | ABS Sensor Retaining Clip | 1 | 97-2 | 97-2 | 97-2 | 97-2 |
| 23 | ABS Tone Ring in Drum | 1 | 24-203 | 24-203 | 24-203 | 24-203 |

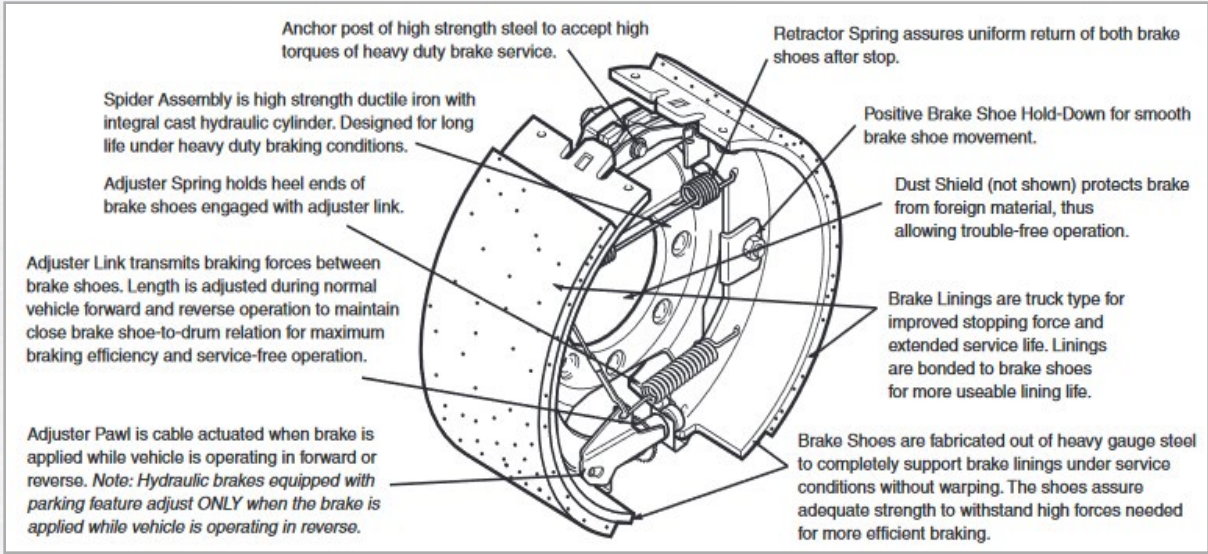

Hydraulic Brake

| Size | Capacity | Part # LH | Part # RH | |
|------------------|------------------|-----------|-----------|-------------|
| 12 1/4" x 3 3/8" | 9K, 10K GD, #13G | 23-410 | 23-411 | Duo-Servo |
| 12 1/4" x 3 3/8" | 9K, 10K GD, #13G | 23-412 | 23-413 | Uni-Servo |
| 12 1/4" x 3 3/8" | 9K, 10K GD, #13G | 23-210 | 23-211 | Duo-Servo* |
| 12 1/4" x 4" | 10K, #13D | 23-404 | 23-405 | Duo-Servo |
| 12 1/4" x 4" | 10K, #13D | 23-414 | 23-415 | Uni-Servo |
| 12 1/4" x 4" | 10K, #13D | 23-168 | 23-169 | Duo-Servo* |
| 12 1/4" x 4" | 10K, #13D | 23-222 | 23-223 | Uni-Servo** |
| 12 1/4" x 5" | 12K | 23-408 | 23-409 | Duo-Servo |
| 12 1/4" x 5" | 12K | 23-416 | 23-417 | Uni-Servo |
| 12 1/4" x 5" | 12K | 23-165 | 23-166 | Duo-Servo* |
| 12 1/4" x 5" | 15K | 23-406 | 23-407 | Duo-Servo |
| 12 1/4" x 5" | 15K | 23-162 | 23-163 | Duo-Servo* |

* Duo-Servo brake with park is equipped with a rear self-adjusting feature.
 ** Uni-Servo brake with park is equipped with a manual adjusting feature.

Hydraulic System Installation Suggestions

1. Use 3/8" steel tubing having 2000 PSI working pressure rating for all hardline connections between the actuator and take-off to axle. All tubing must have double flare connection at joints.
2. Anchor hydraulic tubing securely to frame and axle.
3. Use inverted flare fittings having 82° included angle.
4. Use D.O.T. high pressure hydraulic hose for flex connection(s) (frame to axle).

WARNING: It is the brake system installer's responsibility to ensure compatibility between towing vehicles and trailer actuation systems. Various combinations of Air/Hydraulic, E/H or Vacuum/Hydraulic and tow vehicle systems can allow normal working pressure to exceed 1000 PSI on drum brakes. Pressures in excess of 1000 PSI on drum brakes increase lining wear and can lead to component failure. Make certain your system has the correct peak pressure to activate brakes properly.

BRAKES AND COMPONENTS

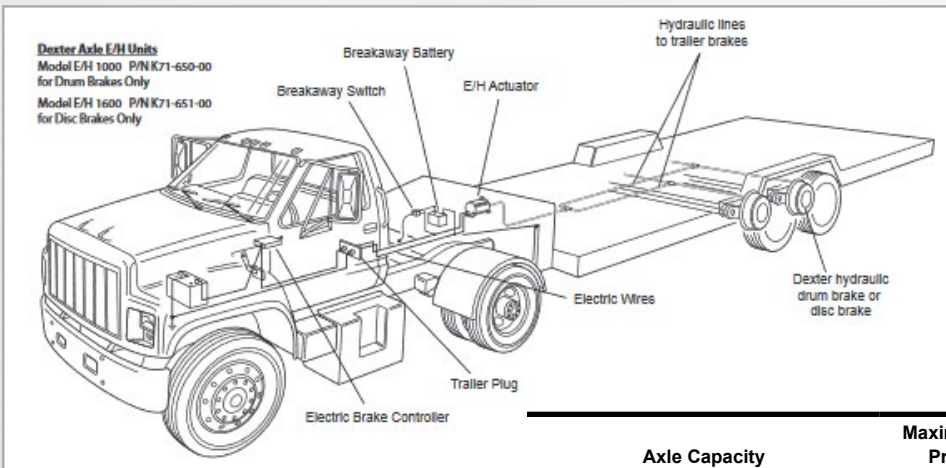

| Axle Capacity | Maximum Operating Pressure (PSI) | Total Fluid Displacement Required per Axle |
|---------------------------------------------------------------------|----------------------------------|--------------------------------------------|
| 9K, 10K, 12K, #13D, #13G Drum Brakes 1 1/4" Diameter Cylinder* | 1000 | 1.30 cu. in. |
| 10K, 12K, #13D Disc Brakes 2 1/2" Diameter Piston (Quantity 2)** | 1600 | .80 cu. in. |
| 15K Drum Brakes 1 3/8" Diameter Cylinder* | 1000 | 1.50 cu. in. |

* Use 3/8-24 flare nut fitting on 3/8" tube or hose to connect to back of brake.
 ** Use 1/8-20 straight thread inlet to connect to brake.

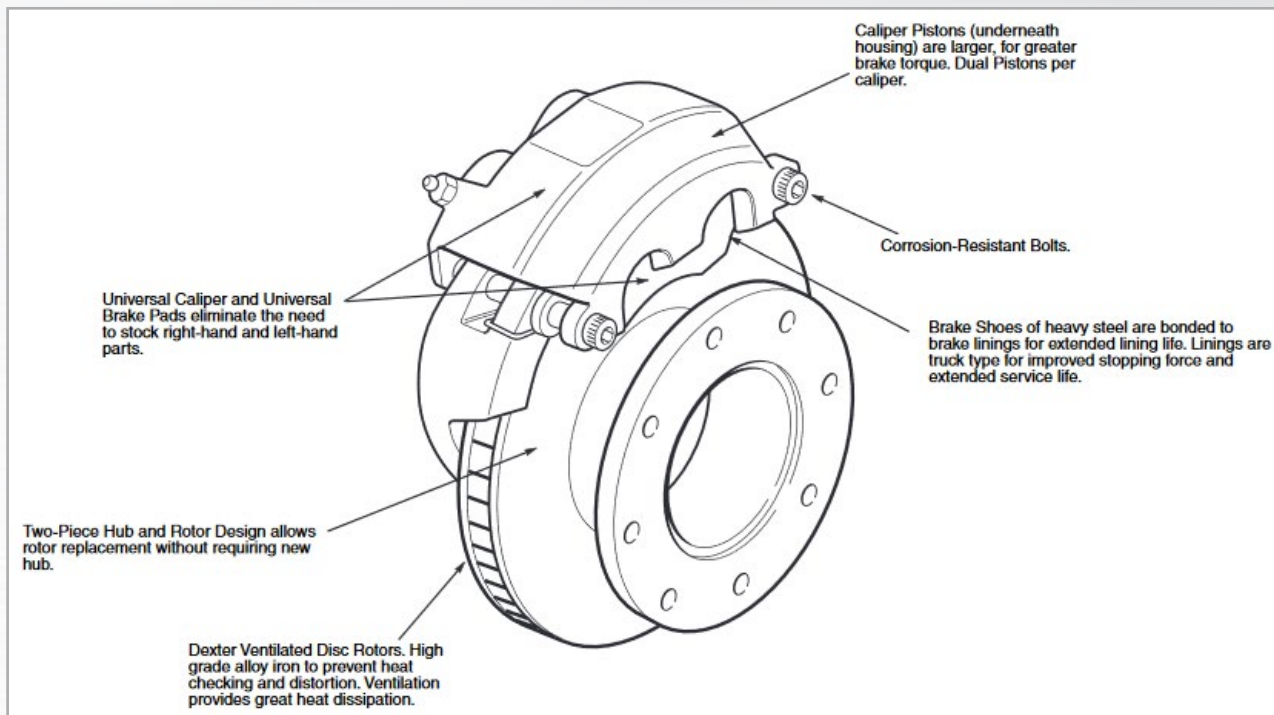

Hydraulic Disc Brake Parts

| Item | Description | Qty per Brake | 10K, 12K | #13G, #13D | #14 |
|------------------------------------------|------------------------------------------------|---------------|----------|------------|---------|
| 1 | Anchor Yoke Assembly (includes 6 of item #6) | 1 | 90-2-2 | 90-2-2 | 90-11-2 |
| 2 | Caliper Assembly (includes items #6, 3, 9, 10) | 1 | 89-2-2 | 89-2-2 | 89-2-2 |
| 3 | Caliper Piston | 2 | 54-66 | 54-66 | 54-66 |
| 12 | Shoulder Screw 5/8 x 5 | 2 | 7-186 | 7-186 | 7-186 |
| 13 | Hex Screw 7/16 -20 x 1.75 | 7 | 7-116 | 7-116 | 7-116 |
| 14 | Flange Nut | 8 | 6-46 | 6-46 | - |
| 15 | Hex Nut 7/16 -20 | 7 | 6-17 | 6-17 | 6-17 |
| 16 | Rotor Mounting Stud | 8 | 25-14 | 25-14 | - |
| 17 | ABS Sensor (straight) | 1 | 97-4 | - | - |
| 19 | ABS Sensor Retaining Clip | 1 | 97-2 | - | - |
| 20 | ABS Tone Ring | 1 | 24-203 | - | - |
| 21 | Lock Washer | 7 | 5-8 | 5-8 | - |
| Caliper Repair Kit Contains: | | 1 | K71-181 | K71-181 | K71-181 |
| 6 | "O" Ring | 4 | 10-62 | 10-62 | 10-62 |
| 7 | Bleeder Screw | 1 | 54-69 | 54-69 | 54-69 |
| 9 | Caliper Seal | 2 | 54-67 | 54-67 | 54-67 |
| 10 | Dust Boot | 2 | 54-68 | 54-68 | 54-68 |
| Disc Brake Replacement Pad Kit Contains: | | 1 | K71-180 | K71-180 | K71-180 |
| 4 | Brake Pad | 4 | 91-3 | 91-3 | 46-105 |
| 5 | Anti-Rattle Spring | 4 | 46-105 | 46-105 | 10-62 |
| 6 | "O" Ring | 20 | 10-62 | 10-62 | 6-125 |
| 8 | Hex Locknut | 4 | 6-125 | 6-228 | 71-182 |
| 11 | Installation Tool | 1 | 71-182 | 71-182 | - |

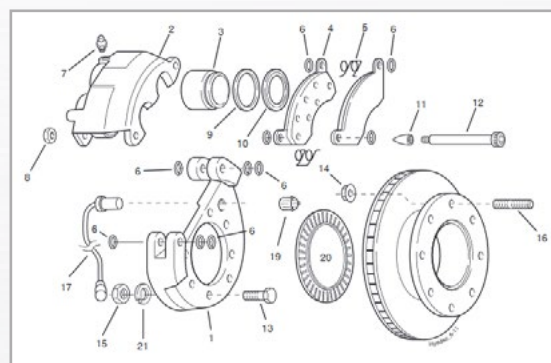

Recommended hose with banjo fitting.
7/16 -20 threaded hole for fitting.
ABS not available on #13G or #13D.

Air Brake Air Brake - "PQ" Style

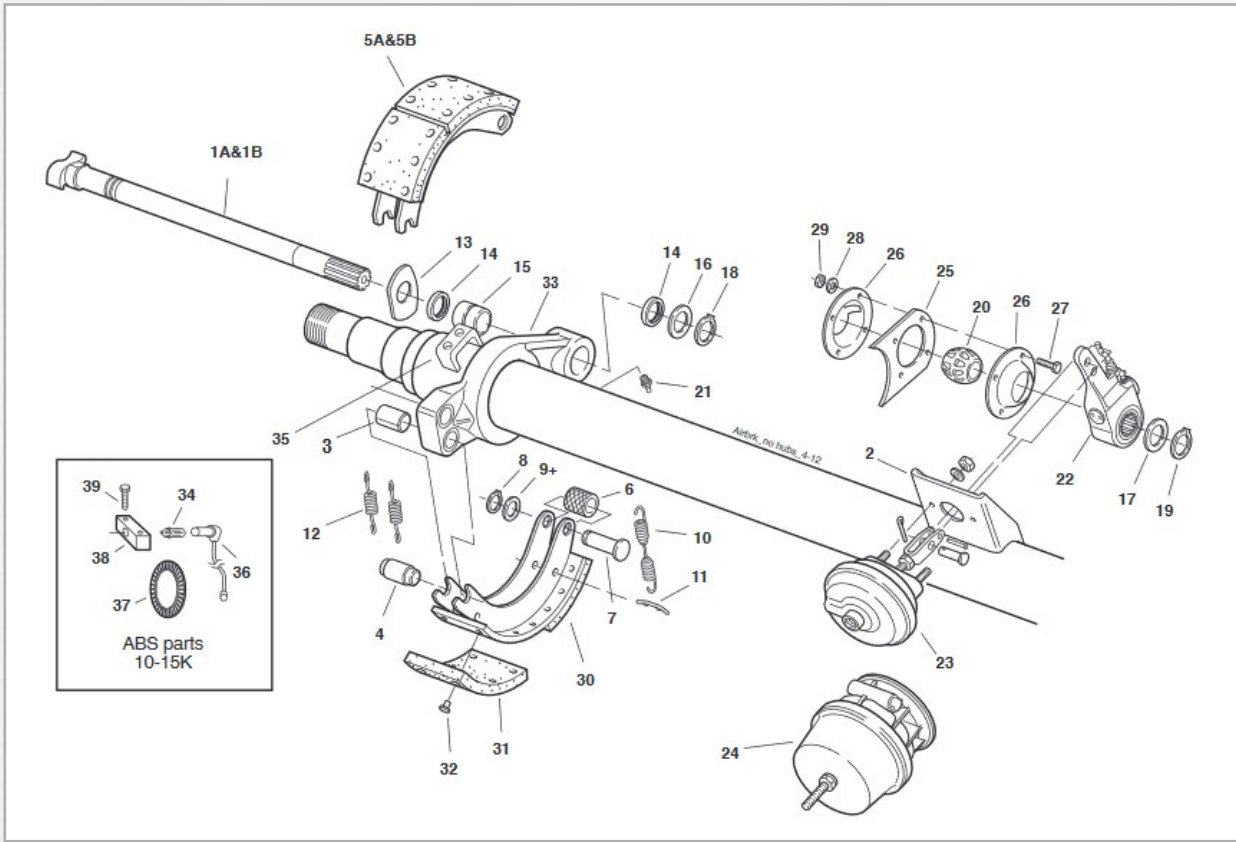

BRAKES AND COMPONENTS

| Item | Description | Qty per Brake | 12 1/4" x 4" 10K Part # | 12 1/4" x 5" 12K, 15K Part # |
|------------------------|--------------------------------------|---------------|-------------------------|------------------------------|
| 1A | Camshaft LH* | 1 | 34-188-xx | 34-188-xx |
| 1B | Camshaft RH* | 1 | 34-189-xx | 34-189-xx |
| 2 | Air Chamber Bracket | 1 | 34-48 | 34-48 |
| 5 | Shoe & Lining Assembly | 2 | 40-321-1 | 40-322-1 |
| 5A | Shoe & Roller Assembly RH | 1 | 40-321-3 | 40-322-3 |
| 5B | Shoe & Roller Assembly LH | 1 | 40-321-2 | 40-322-2 |
| 22 | Automatic Slack Adjuster - 28 Spline | 1 | 55-4-99 | 55-4-99 |
| 22 | Manual Slack Adjuster - 28 Spline | 1 | 55-39 | 55-39 |
| 23 | Air Chamber w/Hardware | 1 | 34-26 | 34-59 |
| 24 | Air Chamber w/Spring Break | 1 | 34-261 | 34-6 |
| 25 | Plate - Camshaft Support Bracket | 1 | 34-31 | 34-31 |
| 26 | Plate, Brushing Retainer | 2 | 34-32 | 34-32 |
| 27 | Bolt, Retainer Plate | 4 | 7-139 | 7-139 |
| 28 | Lockwasher | 4 | 5-79 | 5-79 |
| 29 | Nut | 4 | 6-99 | 6-99 |
| 33 | Brake Spider | 1 | 36-113-2 | 36-113-2 |
| ABS Components: | | | | |
| 34 | ABS Sensor Retaining Clip | 1 | 97-2 | 97-2 |
| 35 | ABS Sensor Mounting Block | 1 | 24-101 | 24-101 |
| 36 | ABS Sensor 90° | 1 | 97-3 | 97-3 |
| 37 | ABS Tone Ring in Drum | 1 | 24-203 | 24-203 |
| 38 | ABS Upper Sensor Mounting Block | 1 | 24-101-1 | 24-101-1 |
| 39 | Mounting Screw Upper Block | 2 | 7-237 | 7-237 |

* For camshaft with part number xx, see page C-21 for options.

| Item | Description | Qty per Brake | 12 1/4" x 4" 10K Part # | 12 1/4" x 5" 12K, 15K Part # |
|----------------------------------------|----------------------------|---------------|-------------------------|------------------------------|
| Brake Shoe Repair Kit Contains: | | | | |
| 3 | Bushing-Spider Anchor Pin | 2 | 14-68 | 14-68 |
| 4 | Anchor Pin | 2 | 56-17 | 56-17 |
| 6 | Roller | 1 | 14-57 | 14-57 |
| 7 | Roller Pin | 2 | 56-1 | 56-1 |
| 8 | Roller Pin Retainer | 2 | 69-18 | 69-18 |
| 9 | Roller Pin Spacer | 2 | 5-76+ | not used |
| 10 | Retractor Spring | 1 | 46-92 | 46-92 |
| 11 | Retainer Pin | 2 | 56-18 | 56-18 |
| 12 | Shoe Keeper Spring | 2 | 46-97 | 46-97 |
| ns | Instruction Sheet | 1 | 59-553 | 59-553 |
| Camshaft Repair Kit Contains: | | | | |
| 13 | "D" Washer, Camshaft | 2 | 5-74 | 5-74 |
| 14 | Grease Seal | 1 | 10-52 | 10-52 |
| 15 | Camshaft Brushing | 1 | 14-56 | 14-56 |
| 16 | Washer-Camshaft Spider End | 1 | 5-75 | 5-75 |
| 17 | Camshaft Washer-28 Spine | 1 | 5-134 | 5-134 |
| 18 | Retainer-Camshaft | 1 | 69-2 | 69-2 |
| 19 | Retainer-Camshaft End | 1 | 69-78 | 69-78 |
| 20 | Camshaft Support Brushing | 1 | 14-58 | 14-58 |
| 21 | Grease Fitting | 1 | 61-6 | 61-6 |
| ns | Instruction Sheet | 1 | 59-663 | 59-663 |
| Brake Block Kit Contains: | | | | |
| 31 | "D" Washer, Camshaft | 2 | 41-52-1 | 41-53-1 |
| 30 | Grease Seal | 2 | 41-52-2 | 41-53-2 |
| 32 | Camshaft Brushing | 24 | 22-18 | 22-48 |

ns - not shown

+ - 5-76 is required for 10K shoes with 1/4" shoe web thickness. Not required for 5/16" shoe web thickness. Used only on 12 1/4" x 4" shoes with 1/4" webs.

Axle/Brake Components

12 1/4" x 7 1/2" Brake Size "PQ" Style

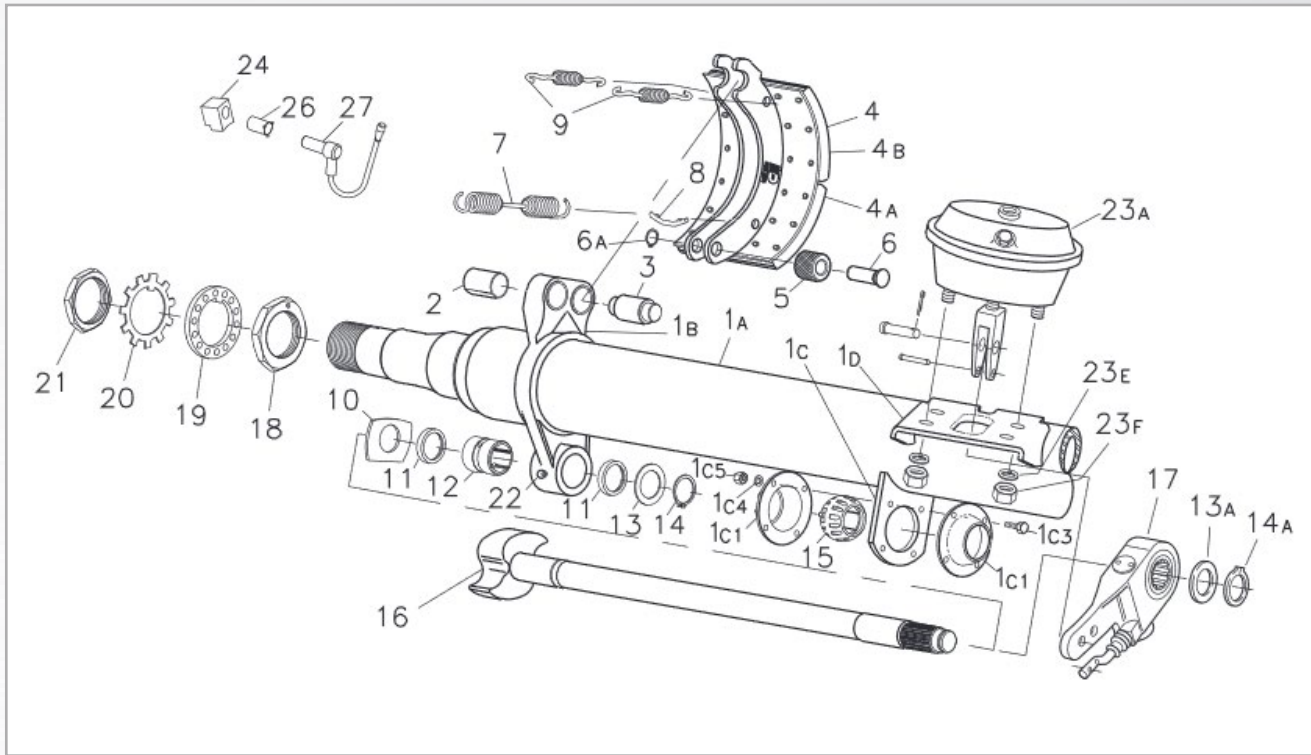

Brake Shoe Hardware Kit

K71-460

Fits "PQ" style Dexter 10-27K 12 1/4" air brake axles.
For one brake.

| DX Part # | Quantity | Part Description |
|-----------|----------|--------------------------|
| 5-76 | 2 | Washer |
| 14-57 | 2 | Roller |
| 14-68 | 2 | Bushing |
| 46-92 | 1 | Retractor Spring |
| 46-97 | 2 | Shoe Keeper Spring |
| 56-10 | 2 | Roller Pin |
| 56-17 | 2 | Anchor Pin |
| 56-18 | 2 | Retainer Pin |
| 69-18 | 2 | Snap Ring for .750 Shaft |
| 59-553 | 1 | Instruction Sheet |

Camshaft Repair Kit

K71-101

Fits "P" and "PQ" style Dexter 10K, 12K, 15K and 12 1/4" x 7 1/2" air brake axles. For one brake.

| DX Part # | Quantity | Part Description |
|-----------|----------|--------------------------|
| 5-74 | 1 | 'D' Washer Camshaft |
| 5-75 | 2 | Camshaft Washer |
| 5-134 | 1 | Plain Washer |
| 10-52 | 2 | Seal |
| 14-56 | 1 | Camshaft Bushing |
| 14-58 | 1 | Camshaft Support Bushing |
| 61-6 | 1 | Grease Fitting |
| 69-2 | 2 | Camshaft Retainer |
| 69-78 | 1 | Snap Ring |
| 59-663 | 1 | Instruction Sheet |

Brake Block Kit

K71-133

For one Dexter 12 1/4" x 7 1/2" brake.

| DX Part # | Quantity | Part Description |
|-----------|----------|-------------------|
| 22-18 | 48 | Rivet |
| 41-57-1 | 2 | Brake Block |
| 41-6-1 | 2 | Brake Block |
| 59-191 | 1 | Instruction Sheet |

Axle/Brake Components

12 1/4" x 7 1/2" Brake Size "PQ" Style



| Item | Part Number | Qty per Axle | Description | Comments |
|------|-------------|--------------|-----------------------------------------------------------|--------------------------------------------------------|
| 1A | D-2L12 | 1 | Beam Options | Light Wall 22,500# rating |
| | D-2M12 | 1 | Beam Options | Medium Wall 25,000# Rating; with Air Ride 22,500# |
| | D-2H12 | 1 | Beam Options | Heavy Wall, 27,500# Rating; with Air Ride 25,000# |
| 1B* | 36-114-2 | 2 | Spider (using anchor pin bushing) | Weld-on (includes #2) |
| 1C | 34-31 | 2 | Bracket - Camshaft Support | Weld-on |
| 1C1 | 34-32 | 4 | Retainer Plate | |
| 1C3 | 7-139 | 8 | Bolt - Retainer Plate Attachment | |
| 1C4 | 5-79 | 8 | Lock Washer - Cover Attachment | |
| 1C5 | 6-99 | 8 | Nut - Retainer Plate Attachment | |
| 1D | 34-48 | 2 | Bracket - Air Chamber Mounting | Weld-on Standard |
| 2 | 14-68 | 4 | Bushing - Spider Anchor Pin | |
| 3 | 56-17 | 4 | Anchor Pin | |
| 4 | 40-320-1 | 4 | Shoe and Lining Assembly | Friction Code FF |
| 4A | 41-6-1 | 4 | Lining - Brake Block Cam | (FMSI 4591 D) |
| 4B | 41-57-1 | 4 | Lining - Brake Block Anchor | (FMSI 4591D) |
| 5 | 14-57 | 4 | Roller | |
| 6 | 56-10 | 4 | Retainer - Roller Pin | |
| 6A | 69-18 | 4 | Retainer Ring | |
| 7 | 46-92 | 2 | Spring - Shoe Retractor | Blue Color |
| 8 | 56-18 | 4 | Retainer Pin - Retractor Spring | |
| 9 | 46-97 | 4 | Spring - Shoe Keeper | Orange Color |
| 10 | 5-74 | 2 | 'D' Washer - Camshaft | .06 Thick |
| 11 | 10-52 | 4 | Grease Seal | |
| 12 | 14-56 | 2 | Bushing - Camshaft Support | Nylon |
| 13 | 5-75 | 1 | Washer | |
| 13A | 5-134 | 2 | Washer - Camshaft Slack Adjuster End | For 28-spline Camshafts only |
| 14 | 69-20 | 2 | Snap Ring | |
| 14A | 69-78 | 2 | Retainer - Camshaft Slack Adjuster End | For 28-spline Camshafts only |
| 15 | 14-58 | 2 | Bushing - Camshaft Support | Nylon |
| 16 | 34-xxx-xx | 2 | Camshaft LH/RH | See Camshaft section on page C-21 for options |
| ns | 55-39 | 2 | Slack Adjuster | 1.46 x 28-spline |
| 17 | 55-4-99 | 2 | Slack Adjuster Angled Automatic 1.46 x 28-spline 6"arm | Boxed kit includes clevis, pins, gage and instructions |
| 18 | 6-114 | 2 | Nut - Inner Spindle Bearing | |
| 19 | 5-98 | 2 | Lock Washer - Indexing | |
| 20 | 5-99 | 2 | Lock Washer - Tab | |
| 21 | 6-115 | 2 | Nut - Outer Spindle | |
| 22 | 61-06 | 2 | Grease Fitting 65° | |
| 23A | 34-xxx-xx | 2 | Air Chamber Assembly (includes item 23E, 23F) | See Air Chamber section on page C-22 for options |
| ns | 55-57 | 2 | Clevis for Manual slacks only | Clevis, Clevis Pin & Cotter Pin for Manual Slacks |
| 23E | | 4 | Lock Washer - Air Chamber Mounting | |
| 23F | | 4 | Nut - Air Chamber Mounting (included in item 23A) | |
| 24 | 24-100 | 2 | Sensor Block | |
| 26 | 97-2 | 2 | Retainer Clip | |
| 27 | 97-3 | 2 | ABS Sensor, 90° | Haldex |
| | 97-7 | 2 | ABS Sensor, 90° | Meritor - Wabco |

* Not for individual resale

xx- See Camshaft section for part number that varies by length

12 1/4" x 7 1/2" Brake Size Small S Head Hi-Rise

28 Spline

| Part Number | | A | B | C |
|-------------|-----------|--------|-------|--------------------------|
| LH | RH | | | |
| 34-188 | 34-189 | 21.125 | 2.219 | For 1.50 Diameter Shaft* |
| 34-188-1 | 34-189-1 | 16.375 | 2.219 | For 1.50 Diameter Shaft* |
| 34-188-3 | 34-189-3 | 22.312 | 2.219 | For 1.50 Diameter Shaft* |
| 34-188-4 | 34-189-4 | 20.312 | 2.219 | For 1.50 Diameter Shaft |
| 34-188-5 | 34-189-5 | 23.375 | 2.219 | For 1.50 Diameter Shaft |
| 34-188-6 | 34-189-6 | 30.000 | 2.219 | For 1.50 Diameter Shaft |
| 34-188-7 | 34-189-7 | 29.000 | 2.219 | For 1.50 Diameter Shaft |
| 34-188-8 | 34-189-8 | 19.500 | 2.219 | For 1.50 Diameter Shaft |
| 34-188-9 | 34-189-9 | 26.500 | 2.219 | For 1.50 Diameter Shaft |
| 34-188-1 | 34-189-1 | 7.437 | 2.219 | For 1.50 Diameter Shaft |
| 34-188-11 | 34-189-11 | 24.625 | 2.219 | For 1.50 Diameter Shaft |

* No extra charge for these lengths

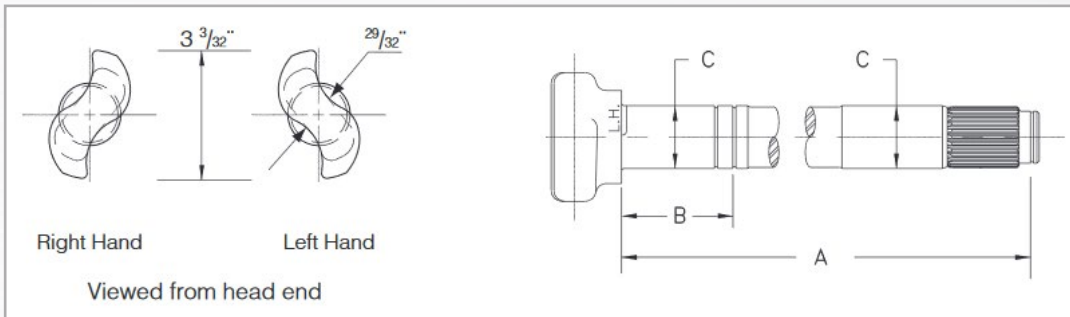

16 1/2" x 7" Brake Size Large S Head Hi-Rise

28 Spline

| Part Number | | A | B | C |
|-------------|-----------|--------|-------|--------------------------|
| LH | RH | | | |
| 34-192 | 34-193 | 16.625 | 2.219 | For 1.50 Diameter Shaft* |
| 34-192-1 | 34-193-1 | 20.375 | 2.219 | For 1.50 Diameter Shaft |
| 34-192-2 | 34-193-2 | 30.000 | 2.219 | For 1.50 Diameter Shaft* |
| 34-192-3 | 34-193-3 | 23.438 | 2.219 | For 1.50 Diameter Shaft |
| 34-192-4 | 34-193-4 | 26.500 | 2.219 | For 1.50 Diameter Shaft |
| 34-192-5 | 34-193-5 | 22.625 | 2.219 | For 1.50 Diameter Shaft |
| 34-192-6 | 34-193-6 | 19.500 | 2.219 | For 1.50 Diameter Shaft |
| 34-192-7 | 34-193-7 | 29.000 | 2.219 | For 1.50 Diameter Shaft |
| 34-192-8 | 34-193-8 | 25.000 | 2.219 | For 1.50 Diameter Shaft |
| 34-192-9 | 34-193-9 | 28.000 | 2.219 | For 1.50 Diameter Shaft |
| 34-192-1 | 34-193-1 | 24.375 | 2.219 | For 1.50 Diameter Shaft |
| 34-192-11 | 34-193-11 | 7.438 | 2.219 | For 1.50 Diameter Shaft |

* No extra charge for these lengths

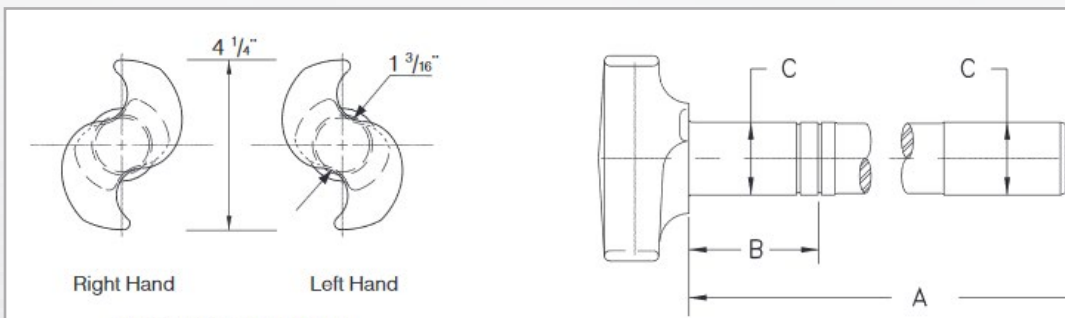

Spring Brake Air Chambers

| Part Number | Size | A | B | C | D | E | F | G | Recommended Application |
|-------------|------------|------|------|------|--------------------|--------------------|------|-----|-------------------------------------------------------------|
| 34-261-7 | Type 20-24 | 5.62 | 7.53 | 1.25 | $\frac{1}{8}$ - 11 | $\frac{1}{8}$ - 18 | 4.75 | .50 | 12 $\frac{1}{4}$ " Brake with Tramec Angled Automatic Slack |
| 34-261-8 | Type 20-24 | 6.38 | 7.53 | 1.25 | $\frac{1}{8}$ - 11 | $\frac{1}{8}$ - 18 | 4.75 | .50 | 12 $\frac{1}{4}$ " Brake with Straight Manual Slack |
| 34-60-1 | Type 24-30 | 7.00 | 7.50 | 1.25 | $\frac{1}{8}$ - 11 | $\frac{1}{8}$ - 18 | 4.75 | .50 | Optional 16 $\frac{1}{2}$ " Brake |
| 34-60-7 | Type 24-30 | 5.62 | 7.50 | 1.25 | $\frac{1}{8}$ - 11 | $\frac{1}{8}$ - 18 | 4.75 | .50 | 12 $\frac{1}{4}$ " Brake with Tramec Angled Automatic Slack |
| 34-60-8 | Type 24-30 | 6.38 | 7.50 | 1.25 | $\frac{1}{8}$ - 11 | $\frac{1}{8}$ - 18 | 4.75 | .50 | 12 $\frac{1}{4}$ " Brake with Straight Manual Slack |
| 34-58-1 | Type 30-30 | 7.00 | 8.50 | 1.25 | $\frac{1}{8}$ - 11 | $\frac{1}{8}$ - 18 | 4.75 | .50 | Standard 16 $\frac{1}{2}$ " Brake |
| 34-58-7 | Type 30-30 | 5.62 | 8.50 | 1.25 | $\frac{1}{8}$ - 11 | $\frac{1}{8}$ - 18 | 4.75 | .50 | 12 $\frac{1}{4}$ " Brake with Tramec Angled Automatic Slack |
| 34-58-8 | Type 30-30 | 6.38 | 8.50 | 1.25 | $\frac{1}{8}$ - 11 | $\frac{1}{8}$ - 18 | 4.75 | .50 | 12 $\frac{1}{4}$ " Brake with Straight Manual Slack |

Note: Clevis assembly NOT included with air chamber. See brake section for clevis kits.
Long stroke (2 $\frac{1}{2}$ ") spring brake air chambers are available.

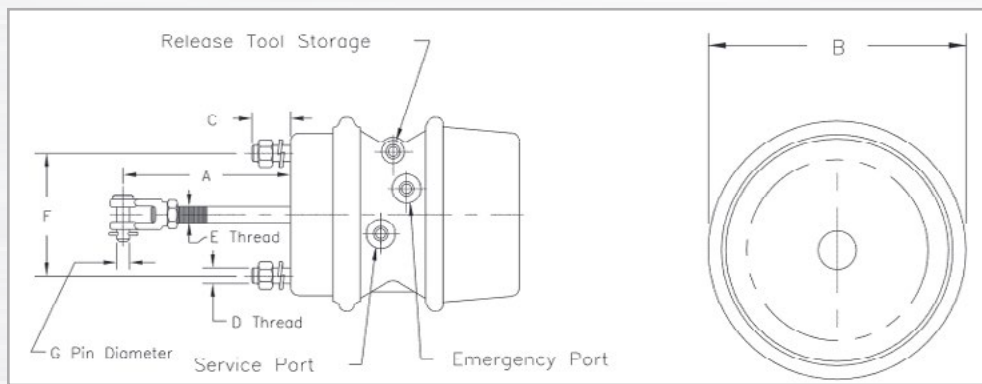

Section E

Tires and Wheels

Single Wheels & Assemblies E-1
Wheel Accessories E-2



TIRES AND WHEELS

SINGLE WHEELS

| Part Number | Bolt Pattern | Size | Width | Pilot | Offset | Style | Capacity (lb) | Finish |
|-------------|--------------|-------|-------|-------|--------|--------|---------------|--------|
| 17-150-7M | 5-5.00" | 15" | 5" | 3.19" | 0" | Mod. | 1820 | Black |
| 17-118 | 6-5.50" | 15" | 6" | 3.65" | 0" | Mod. | 2600 | Black |
| 17-243-7M | 6-5.50" | 16" | 6" | 4.27" | 0" | Mod. | 3500 | Black |
| 17-162-7M | 8-6.50" | 16" | 6" | 4.88" | 0" | Mod. | 3750 | Black |
| 17-163 | 8-6.50" | 17.5" | 6.75" | 4.76" | -.19" | O.E.M. | 6005 | Black |

DUAL WHEELS

| Part Number | Bolt Pattern | Size | Width | Pilot | Offset | Style | Capacity (lb) | Finish |
|-------------|--------------|-------|-------|-------|--------|--------|---------------|--------|
| 17-279 | 8-6.50" | 16" | 6" | 4.77" | 5.35" | O.E.M. | 3500 | Black |
| 17-280 | 8-6.50" | 17.5" | 6.75" | 4.77" | 5.67" | O.E.M. | 5675 | Black |

12" ASSEMBLY

| Part Number | Bolt Pattern | Tire Size | Tire Type | Load Range | Capacity (lb) | Style |
|--------------|--------------|-----------|-----------|------------|---------------|-------|
| WT44012 | 4 - 4.0" | 4.80 x 12 | Bias | C | 785 | Black |
| WT5.45480X12 | 5 - 4.5" | 4.80 x 12 | Bias | C | 990 | Black |

13" ASSEMBLY

| Part Number | Bolt Pattern | Tire Size | Tire Type | Load Range | Capacity (lb) | Style |
|----------------|--------------|-----------|-----------|------------|---------------|-------|
| WT5.4517580D13 | 5 - 4.5" | 175/80D13 | Bias | C | 1360 | Black |

14" ASSEMBLY

| Part Number | Bolt Pattern | Tire Size | Tire Type | Load Range | Capacity (lb) | Style |
|----------------|--------------|-----------|-----------|------------|---------------|-------|
| WT5.4520575D14 | 5 - 4.5" | 205/75D14 | Bias | C | 1760 | Black |

Black

15" ASSEMBLY

| Part Number | Bolt Pattern | Tire Size | Tire Type | Load Range | Capacity (lb) | Style |
|----------------|--------------|-----------|-----------|------------|---------------|-------|
| WT5.4520575D15 | 5 - 4.5" | 205/75R15 | Radial | C | 1820 | Black |
| WT5.4522575R15 | 5 - 4.5" | 225/75R15 | Radial | D | 2540 | Black |
| WT5.5020575D15 | 5 - 5.0" | 205/75D15 | Bias | C | 1820 | Black |
| WT5.5020575R15 | 5 - 5.0" | 205/75R15 | Radial | C | 1820 | Black |
| WT5.5022575R15 | 5 - 5.0" | 225/75R15 | Radial | D | 2540 | Black |
| WT6.5522575D15 | 6 - 5.5" | 225/75R15 | Radial | D | 2540 | Black |

16" ASSEMBLY

| Part Number | Bolt Pattern | Tire Size | Tire Type | Load Range | Capacity (lb) | Style |
|----------------------|--------------|-----------|-----------|------------|---------------|-------|
| WT6.5523580R16 | 6 - 5.5" | 235/80R16 | Radial | E | 3520 | Black |
| WT8.6523580R16DUAL | 8 - 6.5" | 235/80R16 | Radial | E | 3080 | Black |
| WT8.6523580R16SINGLE | 8 - 6.5" | 235/80R16 | Radial | E | 3520 | Black |
| WT8.6523585R16DUAL | 8 - 6.5" | 235/85R16 | Radial | E | 3860 | Black |
| WT8.6523585R16SINGLE | 8 - 6.5" | 235/85R16 | Radial | E | 4400 | Black |

17.5" ASSEMBLY

| Part Number | Bolt Pattern | Tire Size | Tire Type | Load Range | Capacity (lb) | Style |
|----------------------|--------------|-------------|-----------|------------|---------------|-------|
| WT8.6521575R17.5DUAL | 8 - 6.5" | 215/75R17.5 | Radial | H | 4050 | Black |
| WT8.6521575R17.5SING | 8 - 6.5" | 215/75R17.5 | Radial | H | 4805 | Black |
| WT865235R175 | 8 - 6.5" | 235/75R17.5 | Radial | J | 6005 | Black |

TIRES AND WHEELS

WHEEL ACCESSORIES

| Part Number | Description |
|-------------|----------------------------------------------------------------|
| 15-2 | Plated Rim Clamp |
| 33-52-1 | Clamp Ring for 9K - 12K Axles; Alignment Slot and Torque Stamp |
| 6-80 | ½ - 20 60° Cone Lug Nut; Zinc or Cadmium Plated |
| 6-53 | ⅜ - 18 60° Cone Lug Nut; Zinc Plated |
| 6-109 | ⅝ - 18 90° Cone Lug Nut; Zinc Plated |
| 6-58 | ⅝ - 18 Flange Wheel Nut; Zinc Plated |
| 6-118 | Flange Nut; Swivel for 15K; M22 |
| 6-209 | Swivel Flange Wheel Nut; 5/8-18 Teflon PTFE, Rev D |



33-52-1



6-58



6-80



6-209



15-2



Section F

Fender and Body

| | |
|------------------------------------------|-----|
| Single & Tandem Axle Fenders | F-1 |
| Triple Axle Fenders & Fender Backs | F-2 |
| Tool Boxes & Shocks..... | F-2 |
| Paint and Accessories | F-3 |



FENDERS

SINGLE AXLE FENDER

| Part Number | Width | Length | Stretch Out | Height | Gauge | Description |
|-------------|-------|--------|-------------|--------|-------|-----------------------------------------|
| 72810 | 7 | 28 | 36 | 10 | 16 | Single Axle Fender; 1" Radius |
| 932 | 9 | 32 | 48 | 15 | 16 | Single Axle Fender; 1" Radius |
| 932FP | 9 | 32 | 54 | 16 | 14 | Single Axle Fender; Double Square Broke |
| 936FP17 | 9 | 36 | 60.5 | 17.5 | 14 | Single Axle Fender; Double Square Broke |
| 103436 | 10.75 | 36 | 60 | 18 | 16 | Single Axle Fender; 1" Radius |

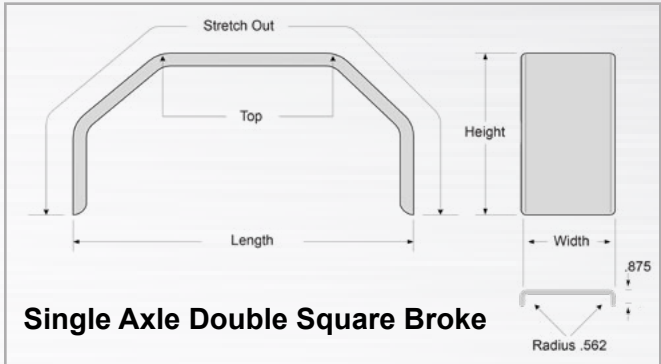
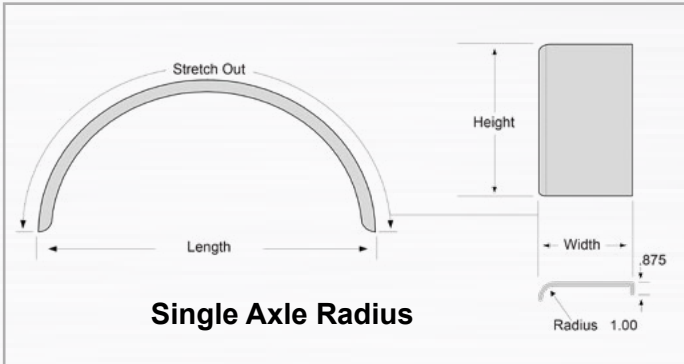

TANDEM AXLE FENDER

| Part Number | Width | Length | Stretch Out | Height | Gauge | Description |
|-------------|-------|--------|-------------|--------|-------|--------------------------------------------------|
| 972W18 | 9 | 72 | 94 | 19 | 16 | Tandem Teardrop Fender; 1" Radius |
| 972R | 9 | 72 | 96 | 20 | 16 | Tandem Straight Fender; 1" Radius |
| 972WFP | 9 | 72 | 96 | 20 | 14 | Tandem Teardrop Fender Floor Plate |
| 972FP | 9 | 72 | 96 | 17 | 14 | Tandem Straight Fender Floor Plate; Double Broke |
| 103472 | 10.75 | 72 | 96 | 20 | 16 | Tandem Teardrop Fender; 1" Radius |
| 103472WFP | 10.75 | 72 | 96 | 20 | 14 | Tandem Teardrop Fender Floor Plate |

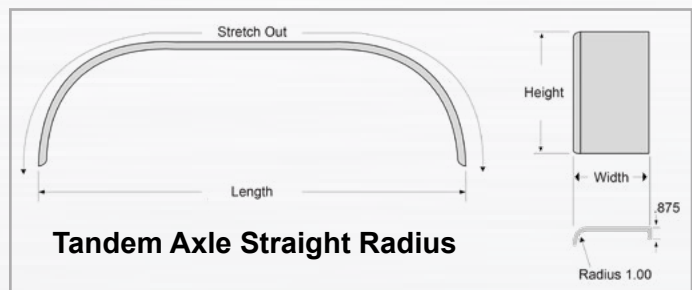
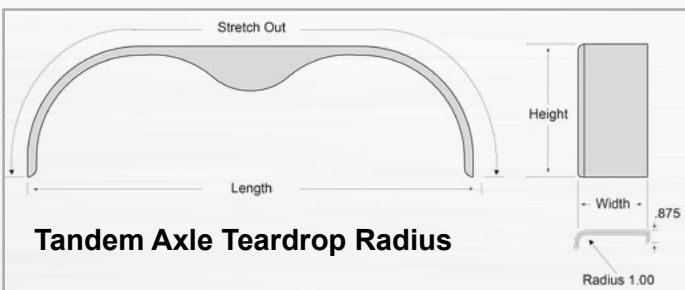

FENDERS

TRIPLE AXLE FENDER

| Part Number | Width | Length | Stretch Out | Height | Gauge | Description |
|-------------|-------|--------|-------------|--------|-------|------------------------------------------------------|
| 9108FP | 8 | 108 | 139 | 20 | 14 | Triple Axle Teardrop Floorplate; Double Square Broke |
| 9108WFP | 9 | 108 | 133 | 21 | 14 | Triple Axle Teardrop Floorplate; 1" Radius |

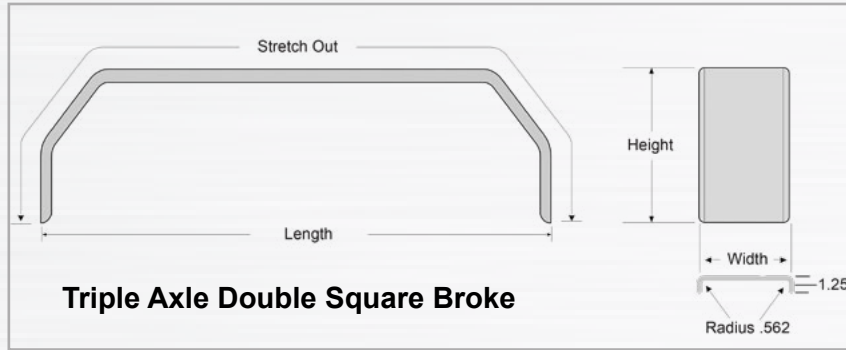

FENDER BACK

| Part Number | Height | Length | Gauge | Description |
|-------------|--------|--------|-------|----------------------------------------|
| 1231 | 12 | 31 | 18 | Pre-cut Radius Back |
| 1231FP | 12 | 31 | 14 | Pre-cut Double Square Broke Floorplate |
| 1268 | 12 | 68 | 18 | Pre-cut Radius Back |
| 1271 | 12 | 72 | 16 | Square Fender Back |
| 1272 | 12 | 70.75 | 14 | Pre-cut Double Square Broke Floorplate |
| 1269FP | 12 | 69 | 14 | Pre-cut Radius Floorplate |

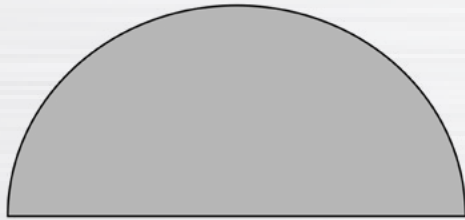

Single Axle Radius Fender Back



Tandem Axle Radius Fender Back

TOOL BOXES & SHOCKS

| Part Number | Description |
|-------------|-----------------------------------------------------------------------------------|
| TBAF | A-Frame Tool Box without Cutouts; Includes Shock; No Holes; 33" x 18" x 18" x 12" |
| TBDUMP | A-Frame Tool Box with Cutouts for Dump Hoses & Charger; 14 GA; Includes Shock |
| TBSHOCK | Gas Shock for Tool Box |

PAINT AND ACCESORIES

GUSSET

| Item # | Description |
|--------|-----------------------------------|
| 142430 | Gooseneck Gusset 1/4" x 24" x 30" |



142430

PAINT

| Item # | Description |
|--------|----------------------------------|
| 52032 | Safety Blue Quick Dry Enamel |
| 52035 | National Blue Quick Dry Enamel |
| 52048 | Dark Green Quick Dry Enamel |
| 52052 | Safety Yellow Quick Dry Enamel |
| 52060 | New Cat Quick Dry Enamel |
| 52068 | Dark Brown Quick Dry Enamel |
| 52075 | Lead Free Safety Red (Bright) |
| 52013 | Gloss Black Quick Dry Enamel |
| 52017 | White Quick Dry Enamel |
| 52026 | Aluminum Quick Dry Enamel |
| 52084 | Battleship Gray Quick Dry Enamel |



PRIMER

| Item # | Description |
|---------|----------------------------------|
| 28DR134 | Red Oxide Primer, Lead Free |
| 28DH64 | Gray Quick Dry Primer, Lead Free |

PAINT THINNER

| Item # | Description |
|--------|---------------------|
| 7511 | TEC Paint Thinner |
| 7515 | Xylol Paint Thinner |



PIN STRIPER

| Item # | Description |
|--------|----------------------------------------------------|
| 73115 | Craftsman Pin Striper Kit with #93 and #115 Heads |
| 93 | #93 Standard Wheel Head Assembly, .091" Wide Wheel |
| 115 | #115 Wheel Head Assembly, .113" Wide Wheel |
| GUIDE | Right Angle Guide for Pin Striper |



93 or 115



GUIDE



73115

FENDER AND BODY

Section G

Couplers and Jacks

| | |
|-----------------------------------------------|-----------|
| Straight, A-Frame & Adjustable Couplers | G-1 |
| Tow Rings, Mounting Plates & Channels | G-2 |
| Gooseneck Couplers & King Pins | G-2 & G-3 |
| Coupler Accessories | G-3 |
| Actuators & Accessories | G-3 |
| Square & Power Jacks | G-4 |
| A-Frame & Swivel Jacks | G-5 |
| Jack Accessories | G-5 |



COUPLERS

STRAIGHT COUPLERS

| Part No | Ball Size | Tongue Width | Style | Capacity (lb) |
|-----------|-----------|--------------|------------|---------------|
| CT-3001-Z | 2" | 2" | Flip Latch | 3500 |
| CT-5003-Z | 2" | 3" | Flip Latch | 5000 |
| 2B2 | 2" | 2 1/4" | Low Pro | 5000 |
| 2B4 | 2" | 3" | Low Pro | 5000 |



CT-5003-Z



2B2

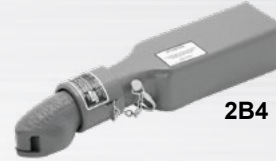

2B4

A-FRAME COUPLERS

| Part No | Ball Size | Style | Capacity (lb) |
|------------|-----------|---------|---------------|
| CA-5210-B | 2" | Yoke | 8000 |
| CA-5196-B | 2" | Low Pro | 7000 |
| CA-5196-X0 | 2" | Low Pro | 7000 |
| 3B8 | 2" | Low Pro | 7000 |
| CA-5296-B | 2 5/16" | Low Pro | 12500 |
| CA-5296-X0 | 2 5/16" | Low Pro | 12500 |
| 4B8 | 2 5/16" | Low Pro | 12500 |
| CA-5280-B | 2 5/16" | Cast | 15000 |



CA-5210-B



CA-5196-B



CA-5280-B



3B8



4B8

ADJUSTABLE COUPLERS

| Part No | Ball Size | Style | Capacity (lb) |
|--------------|-----------|-----------------------------------------------------|---------------|
| CTA-196 | 2" | Forged; fits inside Adjustable Channel | 7000 |
| 3B6M | 2" | Forged; fits inside 2-7/8" Channel | 7000 |
| CTA-16825-81 | 2" | DEMCO Coupler EZ-LATCH; Bolts Not Included | 10000 |
| CTA-296 | 2 5/16" | Forged; fits inside Adjustable Channel | 12500 |
| 4B6M | 2 5/16" | Forged; fits inside 2-7/8" Channel | 12500 |
| CTA-280 | 2 5/16" | Cast | 15000 |
| CTA-80PL | 2 5/16" | Flat Plate | 20000 |
| R25160 | 2 5/16" | Cast | 20000 |
| CTA-14040-81 | 2 5/16" | DEMCO Coupler EZ-Latch; Bolts Not Included | 21000 |
| 4425000317 | 2 5/16" | Wedge-Latch Cast; Flat Plate Mount | 25000 |
| CTA-17415-81 | 2 5/16" | DEMCO Flat Mount EZ-LATCH; 4 Bolt Mount; 5/8" Holes | 25000 |



CTA-280



CTA-80PL



4425000317



4B6M



CTA-196



R25160



3B6M

COUPLERS

TOW RINGS

| Part No | Description | GVWR (lb) | Max Vertical Tongue Load (lb) |
|----------|------------------------------------|-----------|-------------------------------|
| 18128 | 3" Lunette Eye without Channel | 14000 | - |
| 16137 | 3" Lunette Eye without Channel | 20000 | - |
| DB125015 | Drawbar with 4-Bolt Mounting Plate | 42000 | 7000 |
| DB1385 | Drawbar with 4-Bolt Mounting Plate | 60000 | 15000 |
| 9095 | Dico Adjustable 3/4" Clevis Hitch | 12000 | - |



16137



DB125015



DB1385



9095

MOUNTING PLATES & CHANNELS

| Part No | Description |
|---------|--------------------------------------------------------------------|
| 8978 | Adjustable Channel; 3 Position; 4 Hole |
| 8978XL | Adjustable Channel; 11 1/2" Long; 6 Hole |
| 34615 | Adjustable Drawbar Mounting Plate; 3/4" x 8" x 15" with 5/8" Holes |
| 3461534 | Adjustable Drawbar Mounting Plate; 1" x 8" x 15" with 3/4" Holes |



8978



34615



8978XL

GOOSENECK COUPLERS

| Part No | Ball | Tube | Retracted Ht. | Adjustment | Capacity (lbs) |
|--------------|---------|--------------------|---------------|------------|----------------|
| GCPN-25008 | 2-5/16" | 4.5" Round | 29.2" | 8" | 25000 |
| GCPN-30008 | 2-5/16" | 4.5" Round | 29.2" | 8" | 30000 |
| GCSQ-25008 | 2-5/16" | 4.5" Square | 32" | 8" | 25000 |
| GCSQTW-30000 | 2-5/16" | 4.5" Topwind Crank | 32" | 7" | 30000 |
| 1289200300 | 3" | Square | 22" | 2.6" | 40000 |



GCPN-25008



GCSQTW-3000



GCSQ-25008

COUPLERS

KING PINS

| Part No | Description |
|----------|---------------------------------------------------------------------|
| KP5G-R25 | Round Adjustable with 3/4" Set Screws; 25000 GTW with 3/4" Load Pin |
| KPT809F | 2" SAE; .38" Bolster Plate Thickness; No Holes |

KP5G-R25



KPT809F



COUPLER ACCESSORIES

| Part No | Description |
|---------------|-------------------------------------------|
| UTL100 | 1-7/8" - 2-5/16" Coupler Lock |
| HAM0252010201 | Pin and Chain for Cast Coupler |
| 7-99 | Adjustable Coupler Bolt and Nut 5/8" x 5" |
| GCPN-PIN | Gooseneck Load Bearing Pin |
| 3132 | 2-5/16" Conversion Kit |



UTL100



3132

HYDRAULIC ACTUATORS

Hydraulic

| Part No | Coupler | GVWR (lb) | Description |
|---------|--------------|-----------|------------------------------|
| 16039 | 2 5/16" Ball | 12500 | A-Frame mount |
| 16075 | 2 5/16" Ball | 12500 | Model 10 |
| 24046 | - | 12500 | Model 10 with 4 hole channel |
| 15210 | 2 5/16" Ball | 20000 | Model 20 |
| 18991 | - | 20000 | Model 20 with 4 hole channel |

Electro-Hydraulic Pump

| Part No | Description |
|-------------|------------------------------------------------------------------------------------------|
| *K71-650-00 | For Dexter 3.5K - 15K hydraulic drum brakes; provides 1000# PSI maximum output pressure. |
| *K71-651-00 | For Dexter 3.5K - 12K hydraulic disc brakes; provides 1600# PSI maximum output pressure. |
| 97-11 | Dexter cap for electric over hydraulic unit |

* Two year limited warranty



K71-650-00

K71-651-00

HYDRAULIC ACTUATOR ACCESSORIES

DICO

| Part No | Description |
|---------|-----------------------------------------------------|
| 2374400 | Replacement Master Cylinder Assembly- Model 10 & 20 |
| 1507000 | Dust Cover - Model 10 & 20 |
| 4830600 | Cap - Model 10 & 20 |

BALCRANK

| Part No | Description |
|---------|--------------------------------------|
| 10614 | Replacement Master Cylinder Assembly |
| 1844-2 | Shock Absorber |
| 1833 | Connector |
| 1834B | Connector Bolt |
| 1829 | Master Cylinder Mounting Shaft |
| 1745 | Nylon Bushing |
| 1753 | Locking Hex Nut 1/2-20 |
| 850100 | Cap |
| 1808-1 | Link Strap |



24046



16039



18991

SQUARE JACKS

| Part No | Support Capacity (lbs) | Lift Capacity (lbs) | Handle | Travel | Height | Total Adj. | Description |
|------------------|------------------------|---------------------|----------|--------|--------|------------|------------------------------------------------------------------------------------------------------------|
| TJD-7000 | 8000 | 7000 | Topwind | 15" | 23.5" | 25.5" | Drop Leg |
| TJDA-7000-00 | 8000 | 7000 | Topwind | 15" | 23.5" | 25.5" | Drop Leg |
| TJD-7000S | 8000 | 7000 | Sidewind | 15" | 25.5" | 25.5" | Drop Leg |
| TJD-12000SP-F | 12000 | 10000 | Sidewind | 12.5" | 28.5" | 25.5" | Drop leg, pin to front, handle, mounting hardware and clip included |
| TJD-12000SP-FNH | 12000 | 10000 | Sidewind | 12.5" | 28.5" | 25.5" | Drop leg, pin to front, handle not included |
| TJD-12020SP-R2 | 12000 | 10000 | Sidewind | 12.5" | 28.5" | 25.5" | Drop leg, pin to side, handle, mounting hardware and clip included |
| TJD-12000-TWSP-R | 12000 | 10000 | Topwind | 12.5" | 23.5" | 25.5" | Drop leg, pin to front, handle, mounting hardware and clip included |
| TJD2SP-12000SP-F | 12000 | 10000 | Sidewind | 12.5" | 28.5" | 25.5" | Pin to front, handle, mounting hardware and clip included |
| TJD2SPSET-50000 | 25000 | 25000 | Sidewind | 12.5" | 26.5" | 25.5" | 2 speed landing gear, drop leg, includes (1) 2 speed jack & (1) single speed jack with handle |
| LG4700-304 | 50000 | 50000 | Sidewind | 13.5" | 29.78" | 25.52" | 2 speed landing gear, drop leg, includes (1) 2 speed jack & (1) single speed jack with handle, pin to side |



TJD-7000 TJDA-7000-00 TJD-7000S TJD-12000SP-FNH TJD2SPSET-50000

POWER JACKS

| Part No | Capacity (lbs) | Description |
|-------------|----------------|----------------------------------------------------------|
| EJ-3508-BBX | 3500 | A-Frame with override handle, 12 volt |
| H-15000 | 15000 | RAM Hydraulic Jack Weld On |
| H-FD | - | Hydraulic Jack Fluid Divider |
| H-PU4 | - | Hydraulic Power Unit Dual Acting 4qt with Remote Pendant |
| H-6WFD | - | Hydraulic 6 Way Splitter Valve |
| H-HS18SS | - | Hydraulic Hose 3/8" x 18" FEM/FEM |
| H-HS72SL | - | Hydraulic Hose 3/8" x 72" 90° FEM, Straight FEM |
| H-F38 | - | 3/8" Hydraulic Fitting |
| H-F3890 | - | 3/8" Hydraulic Fitting 90° |
| H-F38T | - | 3/8" Hydraulic Fitting T-Shape |
| H-15008 | 15000 | Self Contained Hydraulic Jack |



H-15008 H-15000 EJ-3508-BBX

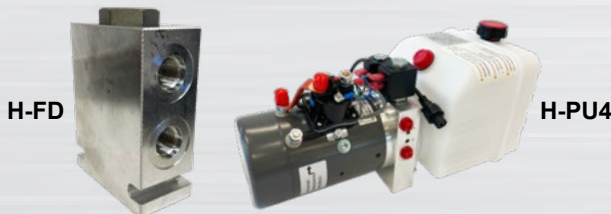

H-FD H-PU4

A-FRAME JACKS

| Part No | Support Capacity (lbs) | Lift Capacity (lbs) | Handle | Travel | Bracket Height | Retracted Height | Description |
|---------|------------------------|---------------------|----------|--------|----------------|------------------|-----------------------------------------|
| AT2000 | 3000 | 2000 | Topwind | 14" | 8" | 20" | Exterior grade black powder coat finish |
| 80391 | 5000 | 5000 | Topwind | 14" | 10.5" | 20" | Exterior grade black powder coat finish |
| 165 | - | 1200 | Sidewind | - | - | - | Hammerblow gear box, A-Frame mount |
| RPSW | 1200 | - | - | 19" | 7.5" | 23.3" | Hammerblow rackpost with steel wheel |



AT2000 165 / RPSW

SWIVEL JACKS

| Part No | Support & Lift Capacity (lbs) | Handle Style | Travel Distance | Bracket Height | Retracted Height | Description |
|----------------|-------------------------------|--------------|-----------------|----------------|------------------|--------------------------------------------------------------------------------------------|
| 151 | 3000 / 2000 | Topwind | 10" | 11.25" | 15.25" | Black powder coat outer tube, clear zinc inner tube |
| 159 | 3000 / 2000 | Topwind | 10" | 11.25" | 15.25" | 5/16" pull pin lanyard, bracket mount, black powder coat outer tube, clear zinc inner tube |
| 158 | 5000 / 3000 | Sidewind | 10" | 11.25" | 17.5" | 5/8" pull pin lanyard, bracket mount, black powder coat outer tube, clear zinc inner tube |
| 15815 | 3000 / 2000 | Sidewind | 15" | 16.25" | 23.25" | 9/16" pull pin lanyard, bracket mount, black powder coat outer tube, clear zinc inner tube |
| TJDP-7000S-FLB | 8000 / 7000 | Sidewind | 15" | 14" | 25.5" | Fixed leg with base |
| MJ-1000W | 1000 / 1000 | Sidewind | 10" | 12.7" | 23.25" | Weld on bracket, 6" caster |
| MJ1001B | 1000 / 1000 | Sidewind | 10" | 12.7" | 23.25" | Bolt on bracket, 6" caster |



151

JACK ACCESSORIES

| Part No | Description |
|-----------------|---------------------------------------------------------------|
| 18405 | Snap ring for foldup jack |
| 80580 | Weld-on bracket for snap ring swivel jack |
| 80570 | Bottom support plate for 2K & 5K A-frame jack |
| JF-99 | Jack foot for 2" tube with bolt |
| 80553 | Caster wheel assembly for 1200 lb capacity |
| HAM015 | 2" weld-on pipe bracket, 9/16" hole diameter |
| HAM016 | 2" weld-on pipe bracket, 5/8" hole diameter |
| HAM017 | 3" weld-on pipe bracket for 7K jack with 5/8" hole diameter |
| XAV-TJA-2000-HD | Top wind handle with bolt and nut for 2K and 5K A-frame jacks |
| XAV-TJPB-HD | Handle with bolt and nut for 151 & 159 swivel jack |
| TJD-7000-HD | 7K topwind jack handle |
| TJD-7000S-HD | 7K sidewind jack handle |
| XAV900 | Handle with bolt for 12K drop leg jack |
| 005120 | Clip for drop leg jack handle |
| TJD-7000-PN | 7K drop leg foot pin, 9/16" |
| TJD-7000-BR | 7K jack bearing |
| TJD-7000S-CP | 7K sidewind jack cap and screw |
| TJD-7000S-GR | 7K jack gear kit |
| TJD-12000-CP | 12K jack cap with screws |
| TJD-12000-GR | 12K jack gear kit |
| TJD-12000-NUT | 12K jack threaded nut |
| TJD-12000-BR | 12K jack bearing |
| SJ-TJSC-24 | 24" Scissor Jack; 5K Capacity |
| SJ-TJSC-24-HD | Scissor Jack Handle |
| SJ-2013 | Stabilizer Jack; 5K Capacity; 13" Outer Tube; 20" Inner Tube |



COUPLERS AND JACKS

Section H

Brake Control & Actuators

| | |
|------------------------------------------|------------|
| Air Kits | H-1 |
| Brake Line Kits | H-1 |
| Brake Controls | H-2 |
| Brake Line Accessories | H-2 |
| Electric/Hydraulic Actuator | H-2 |



BRAKING SYSTEMS

AIR KITS

| Part No | Description |
|-----------|--------------------------------------------------------------------------------------------------------------------------|
| TA8221 | Straight Air Trailer Kit for 2 Axles with Spring Brakes, Single Tank 1 - Axle for ABS Package 1 - Axle without ABS |
| PC-1900-2 | Main Power Cable for TA8221 |
| 12653 | 3/8" Air Line for TA8221; by the ft. |



BRAKE LINE KITS

| Part No | Line | Description |
|---------|------|--------------------------------------------------------|
| T100SA | 15' | Single Axle |
| T200TA | 15' | Tandem Axle |
| T300TR | 15' | Single Axle for Torflex Axle and 3.5K - 8K Disc Brakes |
| T400TR | 15' | Tandem Axle for Torflex Axle and 3.5K - 8K Disc Brakes |
| T1002 | 25' | Tandem Axle for 9K - 15K Hydraulic Drum Brakes |
| T1002D | 25' | Tandem Axle for 10K - 12K Disc Brakes |

T400TR

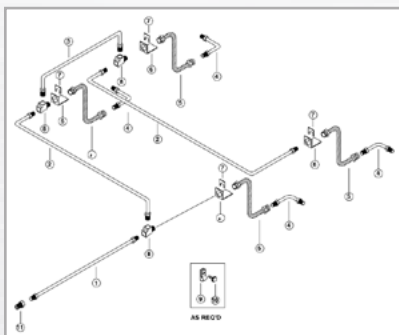

T100SA

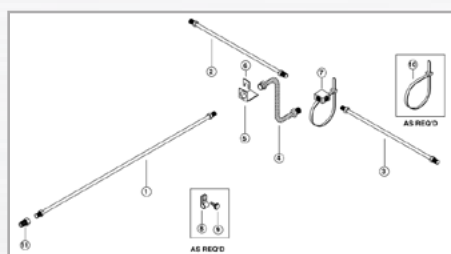

T200TA

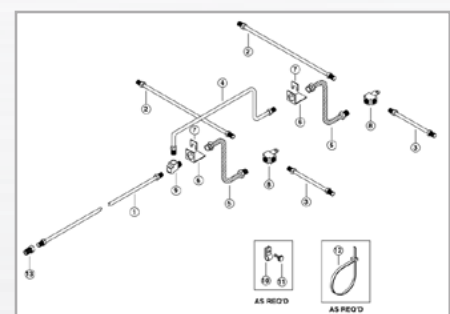
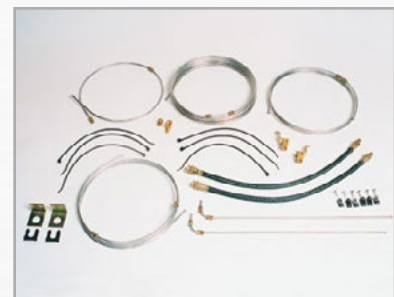

BRAKING SYSTEMS

| BRAKE CONTROLS | |
|----------------|-------------------------------------------------|
| Part No | Description |
| 9058 | Dexter Predator DX2 Brake Controller; 1-2 Axles |



9058

| BRAKE LINE ACCESORIES | |
|-----------------------|---------------------------------------------------------------------------------------------|
| Part No | Description |
| AG-16300-CNF | 3/16" x 25' Coil Tubing |
| 105X3L | Tube Nut |
| 25X15 | Bracket Frame/Hose for Line Kit |
| 1457 | "U" Hose Clip |
| 7900 | Adapter Tee, 3/16", 2 Female and 1 Male |
| 18018-MF | 18" Hydraulic Brake Hose, Male and Female, 3/8" - 24 |
| 14718 | 20.5" Hydraulic Flex Brake Hose, 3/8"-24 Female x 1/4" - 20 Male, for 10K - 12K Disc Brakes |
| 18018-SF | 18" Hydraulic Brake Hose, Male and Female, 3/8" - 24 with 90° bend |



25x15



7900



18018-MF

| ELECTRIC/HYDRAULIC ACTUATOR | | |
|-----------------------------|------------------|----------------------------|
| Part No | PSI (lbs) | Description |
| *K71-650-00 | 1000 | For 3.5K - 15K Drum Brakes |
| *K71-651-00 | 1600 | For 3.5K - 12K Disc Brakes |



* 2 Year Limited Warranty



BRAKE CONTROL AND ACTUATORS

Section I

Lights and Connectors

| | |
|-------------------------------------|--------------|
| LED Tail Lights | I-1 |
| Incandescent Tail Lights | I-2 & I-3 |
| LED Clearance Lights | I-3 thru I-5 |
| Turn Signal Lights | I-5 |
| Incandescent Clearance Lights | I-6 & I-7 |
| Backup Lights | I-8 |
| License Plate Lights | I-9 |
| Grommets & Plugs | I-10 & I-11 |
| Mounting Brackets | I-12 & I-13 |
| Reflectors | I-14 |
| Connectors & Adapters | I-15 |
| Cable & Wire | I-16 |
| Accessories | I-17 |
| Breakaway Kits | I-17 & I-18 |



M844 LED LOW PROFILE

- Combination LED stop, turn and tail light
- Over 80" wide combination tail light
- 6/7 Diodes
- M844L with license light

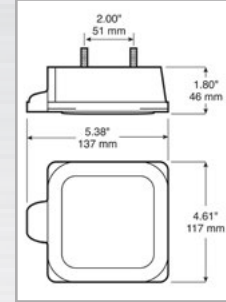

PART Number: M844, M844L



M856 LED

- Combination LED stop, turn and tail light
- Over 80" wide combination tail light
- 10/14 Diodes
- M856L with license light

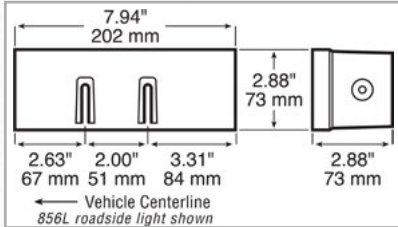

PART Number: M856, M856L

M821R-7 OVAL LED

- Oval LED stop, turn and tail light
- 3 prong plug
- 7 Diodes
- Red grommet mount

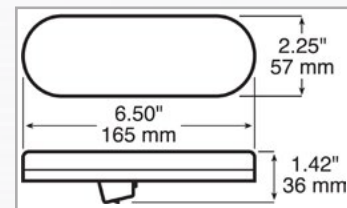
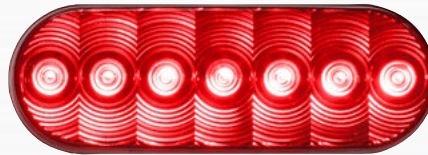

PART Number: M821R-7

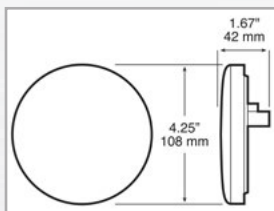

M826R-7 ROUND LED

- 4" Round LED stop, turn and tail light
- 3 prong plug
- 7 Diodes
- Red grommet mount

PART Number: M826R-7

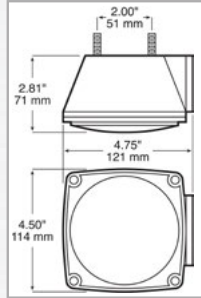

M440 TAIL LIGHT

- Incandescent stop turn and tail light
- Under 80" wide combination tail light
- Functions include stop, turn, tail, rear reflex, side marker & side reflex
- M440L with license light

PART Number: M440, M440L

M444 TAIL LIGHT

- Incandescent stop, turn and tail light
- Over 80" wide combination tail light
- Functions include stop, turn, tail, rear clearance, rear reflex, side marker & side reflex
- M444L with license light

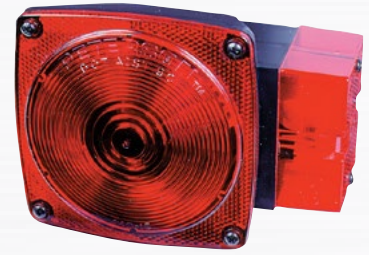
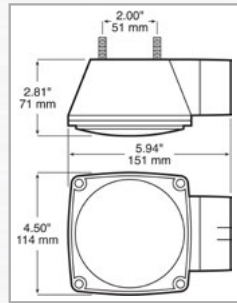

PART Number: M444, M444L

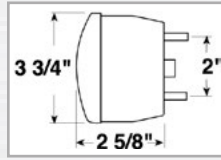

M428 UNIVERSAL STUD-MOUNT

- Incandescent stop, turn and tail light
- Stud-mount combination light that functions as stop, turn, tail and license light (428W only)
- M428W with license light

PART Number: M428S, M428W

M421KR OVAL TAIL LIGHT

- Incandescent oval stop, turn and tail light
- Red light kit includes light, grommet and right angle plug

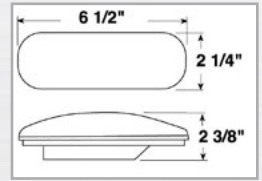

PART Number: 421KR

M426KR ROUND TAIL LIGHT



- Incandescent round stop, turn and tail light
- 4" round long-life
- Red light kit includes light, grommet and 3 wire plug

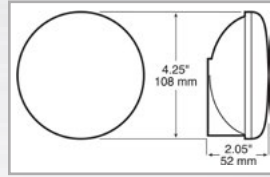

PART Number: M426KR



M540 COMPLETE KIT



- Complete light kit for small trailers under 80" wide
- 540 kit includes:
 - M440/M440L tail lights
 - Two M114A side marker lights
 - 20' trailer harness
 - License bracket
 - Mounting hardware
 - Installation instructions

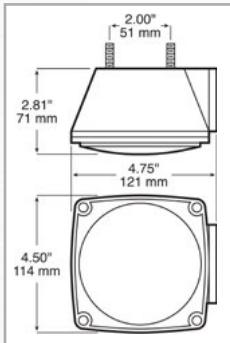

PART Number: M540

M161 LED CLEARANCE / SIDE MARKER LIGHT



- Sealed LED light
- Functions as clearance, side marker or identification light
- 4-diode LED alternative to traditional 154-series incandescent lights
- Features sealed lens and housing and operates from 9-16 volts
- Available in amber (M161A) or red (M161R)

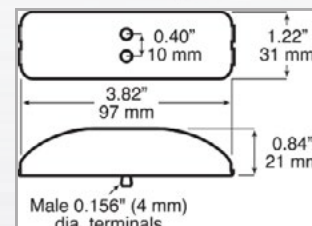

PART Number: M161A, M161R

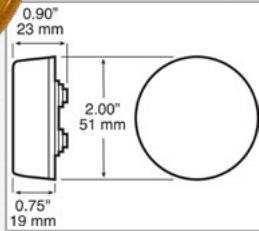
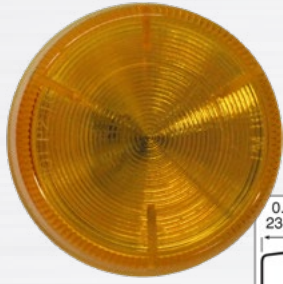

M164 LED CLEARANCE / SIDE MARKER LIGHT

- 2" round sealed LED light
- Functions as clearance, side marker or identification light
- 3 Diodes
- Accepts industry standard 2-prong plug
- Available in amber (M164A) or red (M164R)

PART Number: M164A, M164R

M162 LED CLEARANCE / SIDE MARKER LIGHT



- 2 1/2" round sealed LED light
- Functions as clearance, side marker or identification light
- 3 diodes
- Accepts industry standard 2-prong plug
- Available in amber (M162A) or red (M162R)

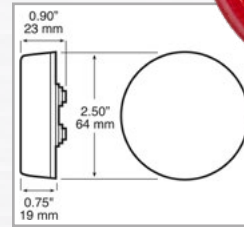

PART Number: M162A, M162R

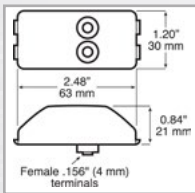

M203 LED CLEARANCE / SIDE MARKER LIGHT



- 2 diode LED
- Lens and base welded together
- Available in amber (M203A) or red (M203R)

PART Number: M203A, M203R

M170 LED CLEARANCE / SIDE MARKER LIGHT



- 2 diode LED
- 2 wire, hard wired design

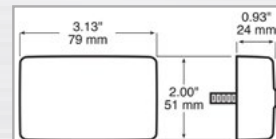
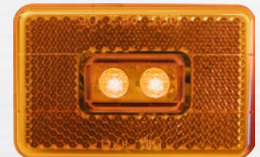

PART Number: M170A

M169-3R IDENTIFICATION LIGHT BAR



- Sealed LED identification light
- 6 diode
- Operates 9-16 volts
- 2 wire, hard wired design

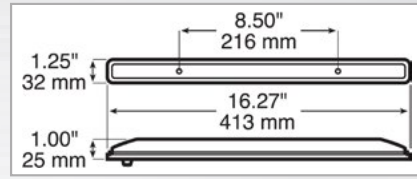
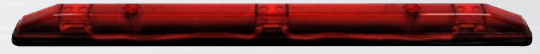

PART Number: M169-3R

MCL-11 LED CLEARANCE / SIDE MARKER LIGHT

- 3 diode LED
- Black rubber grommet included
- Available in amber (M171A) or red (M171R)

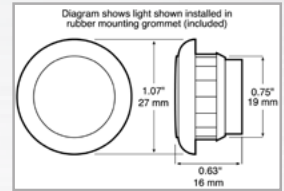

PART Number: M171A, M171R

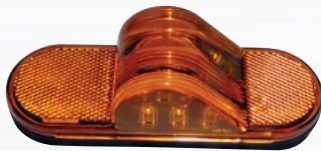

M351 OVAL TURN LIGHT



- Two-function, 6-diode LED light that may be used as auxiliary mid-turn/mid-marker light, while functioning as side marker light and side reflector
- Intergrated industry-standard PL3 socket

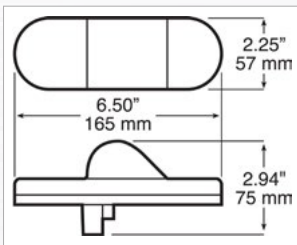

PART Number: M351A

M352 COMBINIATION TURN SIGNAL AND SIDE MARKER



- Kit includes light, 421-18 grommet, and 431- 491 plug
- Mid turn light
- Intergrated industry-standard PL3 socket

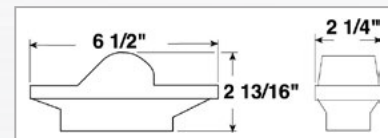

PART Number: M352KA



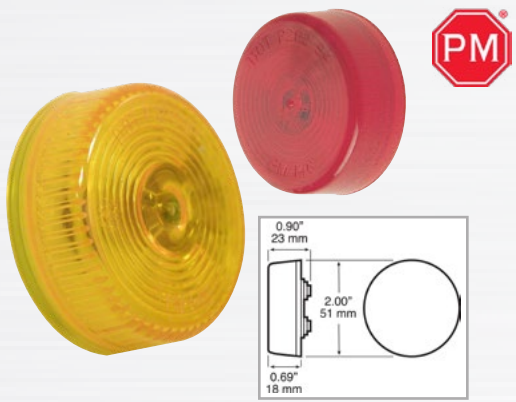

M146 CLEARANCE / SIDE MARKER LIGHT

- 2" round incandescent light
- Functions as clearance or side marker light
- Features sealed lens and housing
- Comes without flange for use with rubber grommet
- Available in amber (M146A) or red (M146R)

PART Number: M146A, M146R

M143 CLEARANCE / SIDE MARKER LIGHT

- 2 1/2" round incandescent light
- Includes built in reflector optics
- Comes without flange for use with rubber grommet
- Available in amber (M143A) or red (M143R)

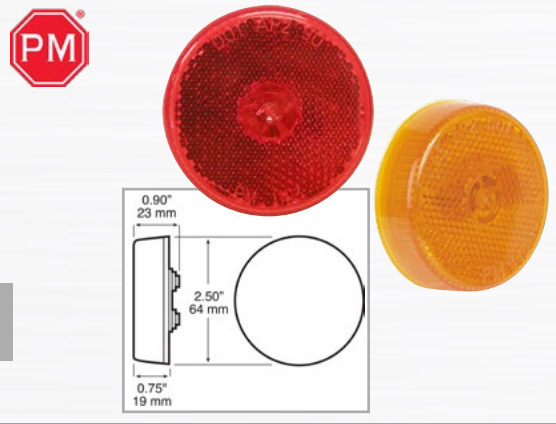

PART Number: M143A, M143R

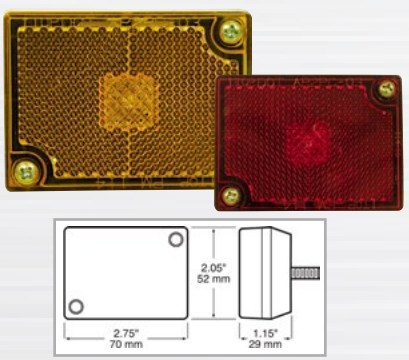

M114 CLEARANCE / SIDE MARKER LIGHT

- Stud-mount incandescent side marker or clearance light
- Includes built in reflector optics
- Available in amber (M114A) or red (M114R)

PART Number: M114A, M114R

M108 CLEARANCE / SIDE MARKER LIGHT

- Incandescent clearance/side marker light
- Built in reflector and precision optics, no separate reflector needed
- Available in amber (M108WA) or red (M108WR)

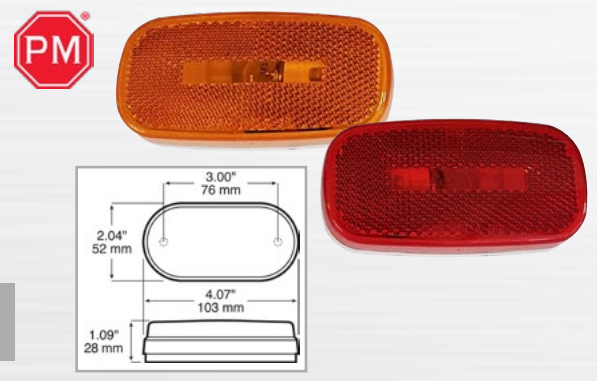

PART Number: M108WA, M108WR

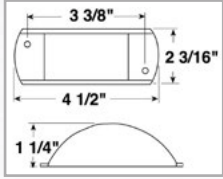

M119 CLEARANCE / SIDE MARKER LIGHT



- Incandescent clearance/side marker light
- Acrylic lens guarded by steel housing
- Can be spot welded
- Available in amber (M119A) or red (M119R)

PART Number: M119A, M119R

M135 CLEARANCE / SIDE MARKER LIGHT



- Incandescent oblong clearance/side marker light
- Two bulbs
- Available in amber (M135A) or red (M135R)

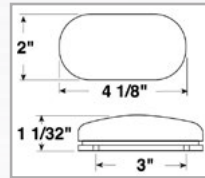

PART Number: M135A, M135R

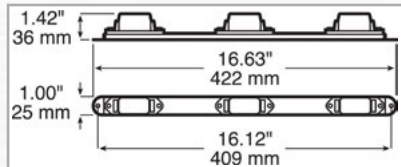

M1073 MINI LIGHT BAR



- Identification bar light for over 80" applications
- Mounts on 16-1/8" centers and grounds throughmounting hardware
- Available in amber (M1073A) or red (M1073R)

PART Number: M1073A, M1073R

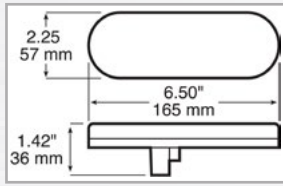

M821C-7 OVAL LED BACK-UP LIGHT



- Oval LED back-up light
- 7 diode
- Accepts PL3 plug

PART Number: M821C-7

M826C-7 ROUND LED BACK-UP LIGHT



- 4" round clear LED back-up light
- 7 diode
- Accepts PL3 plug

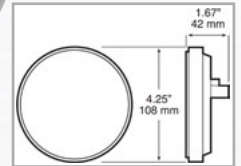

PART Number: M826C-7

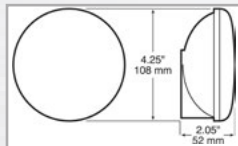

415 ROUND LED BACK-UP LIGHT



- 4" round clear LED back-up light
- 7 diode
- Comes with grommet and plug

PART Number: 415K

416 OVAL BACK UP LIGHT



- Sealed, oval back-up light
- Meets DOT requirement in horizontal or vertical position
- Comes with grommet and plug

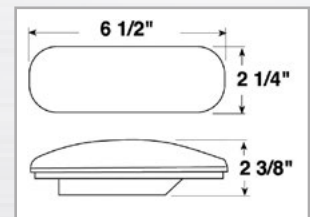

PART Number: 416K

M290 LED LICENSE AND UTILITY LIGHT



- Single diode
- Available with two different spacers for top or side mount installation

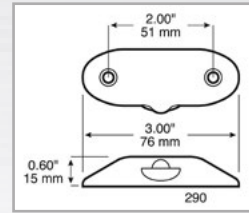

PART Number: M290

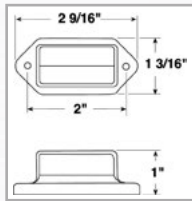

M434 MINI UTILITY LIGHT



- Polished, chrome-plated brass housing with hooded shield to prevent upward glare
- Surface mounts with two stainless steel screws on 2" centers and has separate ground wire for non-metallic surfaces

PART Number: M434

M436 LICENSE PLATE LIGHT



- Internal parts are durable stainless steel or tinned-brass
- Surface mounts on 3 1/4" centers

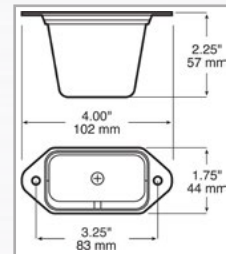

PART Number: M436

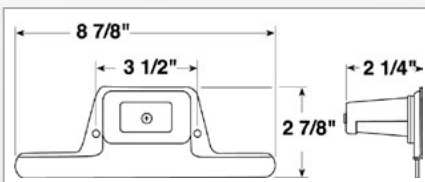

M436B LICENSE PLATE LIGHT



- Internal parts are durable stainless steel or tinned-brass
- Surface mounts on 3 1/4" centers
- M436B includes a black powder-coated, steel license plate bracket riveted to light

PART Number: M436B

MARKER LAMP PLUG



- 2-wire molded plug for clearance and marker lights
- Fits 143, 146, 162 and 164 series clearance and marker lights
- Includes a #10 ring terminal on ground wire; hot wire is stripped



PART Number: B14249

TAIL LIGHT RIGHT ANGLE PLUG



- 3-wire right angle plug for single contact sealed incandescent stop/turn or backup alarms
- Includes #10 ring terminal on ground wire; hot wire is stripped



PART Number: B421491

MOUNTING GROMMET



- Allows flush mounting of 203 series light on metallic or non-metallic surfaces
- Requires 142-49 plug for 2-conductor electrical connections
- Hole specs for 150-18: 2.88" x 1.53" x 11/64" max panel thickness

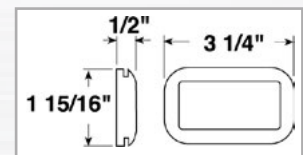

PART Number: B15018



3/4" BLACK GROMMET



- Designed to fit 26 guage steel to 1/4" thick panel (.0179" - .25")
- Made of UV-resistant polymer rubber stays flexible and prevents cracking for extended service life

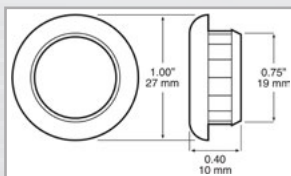

PART Number: B17718

6" OVAL GROMMET



- Black PVC grommet flush mounts oval style lamps
- May be used with 421, 351, 352 and 821 series oval lights and with other similar lights
- Provides additional shock absorbency to extend lamp life

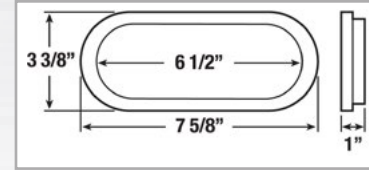

PART Number: B42118

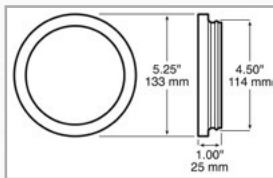

4" ROUND GROMMET



- Black PVC grommet flush mounts 4" diameter round style lamps in 4 1/2" hole
- May be used with 426 and 826 series round stop, turn, and tail lights
- Provides additional shock absorbency to extend lamp life

PART Number: B42618

2" ROUND GROMMET



- Allows 2" diameter sealed units to be flush mounted
- Fits 2 5/16" mounting hole in panels up to .25" thick
- Installation of incandescent lights requires 142-49 plug
- Fits 146 and 164 series lights

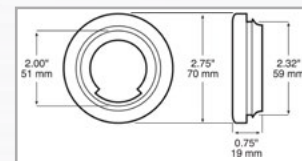

PART Number: B14618

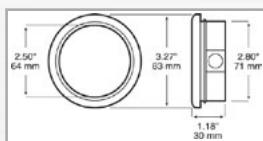

2-1/2" GROMMET



- Allows 2 1/2" diameter sealed units to be flush mounted
- Fits 3" mounting hole
- Fits 143 and 162 series lights

PART Number: B14318

106-09 CHROME GUARD

- Chrome-plated diecast guard provides added protection for oblong lights
- Fits most PM oblong units as well as competitive models

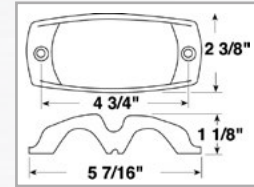
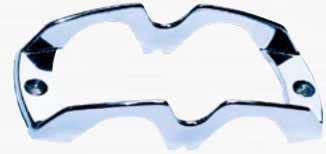

PART Number: B10609



421-09 MOUNTING BRACKET

- Black, powder-coated steel
- For use with 350, 352, 416, 420 or 421 series oval lights, as well as similar competitors' lights
- Requires 421-18 grommet to complete installation

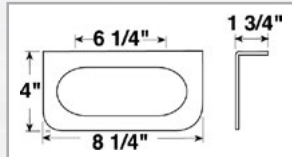

PART Number: 42109

426-09 4" ROUND MOUNTING BRACKET

- Black, powder-coated steel
- For use with 411, 413, 415, 417, 418, 424, 425, 426, and 427 series lights, as well as similar competitors' lights
- Fits all grommet-mounted and most flange-mounted 4" diameter lamps
- Requires 426-18 grommet to complete installation

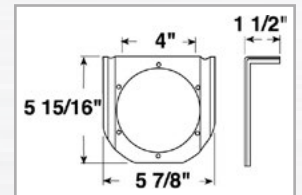

PART Number: 42609

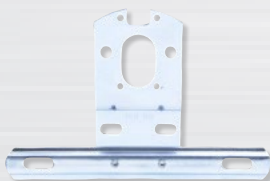

428-09 UNIVERSAL LICENSE BRACKET

- For use with most PM stud-mounted tail lights
- Zinc-plated steel

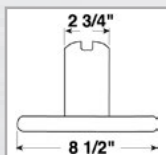

PART Number: 42809

440-09 UNIVERSAL LICENSE BRACKET



- For use with most PM stud-mounted tail lights
- Corrosion-free black or white plastic which flexes on impact

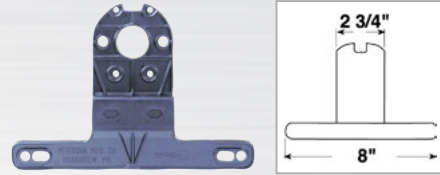

PART Number: 44009

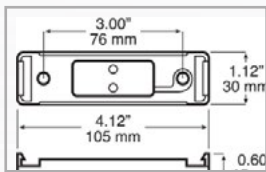

154-11K MOUNTING BRACKET KIT



- Allows 154 and 161 series lights to be surface mounted
- Black Finish
- Mounts on 3" centers

PART Number: B15411K

B421 TAIL LIGHT BOX

- For use with 6" oval lights
- Can use a 2" or 3/4" clearance light
- 16 ga metal



PART Number: B421

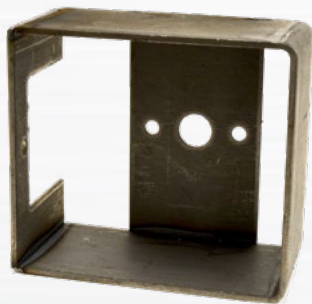

B440 TAIL LIGHT BOX



- Tail light guard
- For use with 440,444 & 844 series lights

PART Number: B440

14609 2" ROUND MOUNTING BRACKET



- For use with 2" clearance lights
- Metal weld on L bracket



PART Number: 14609

472 ALUMINUM OVAL REFLECTOR



- 3" diameter acrylic lens in low-profile, oval, aluminum housing that is rustproof
- Available in amber (B472A) or red (B472R)

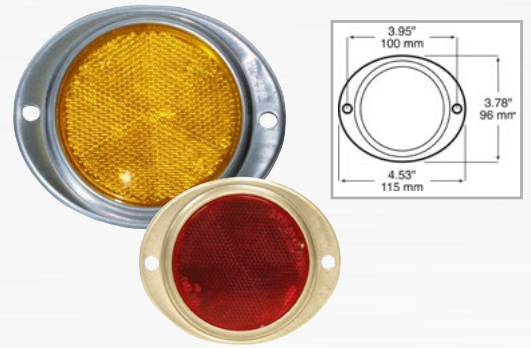

PART Number: B472A, B472R

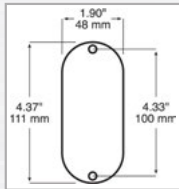

480 OBLONG QUICK-MOUNT REFLECTOR



- 4 3/8" x 1 7/8" acrylic lens with adhesive backing
- May also be mounted on 3 15/16" centers
- Available in amber (B480A) or red (B480R)

PART Number: B480A, B480R

489 RECTANGULAR REFLECTOR



- High-strength, pressure-sensitive adhesive backing
- Rectangular reflector measures 2 3/4" x 1 3/4"
- Available in amber (B489A) or red (B489R)

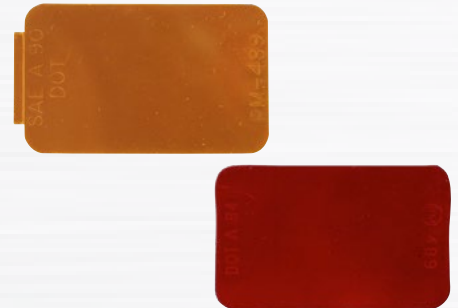

PART Number: B489A, B489R

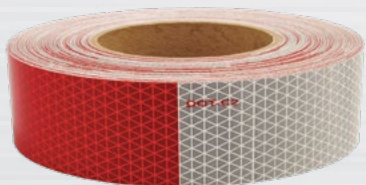
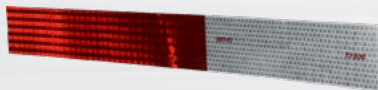

DOT REFLECTIVE TAPE

- 2" wide
- 11" red, 7" silver per strip
- Available in 150' rolls (4654)
- Available in 18" strips (4655)

PART Number: 4654, 4655

TRAILER SIDE CONNECTORS



412

- 4 Flat
- 12" Length



63

- 6 Round (Metal)
- HD, die-cast zinc housing



10011

- 7 Blade
- Impact and corrosion resistant



10014

- 7 Round (Metal)
- Impact and corrosion resistant



10012

- 7 Blade
- Molded cable

VEHICLE SIDE CONNECTORS



448

- 4 Flat
- 48" Length



62

- 6 Round (Metal)
- HD, die-cast zinc housing



10010

- 7 Blade
- ABS plastic housing



10013

- 7 Round (Metal)
- HD, die-cast zinc housing

ADAPTERS



9947

- 7 Blade to 6 Round and 4 Flat
- Provides multiple towing options from on connector
- Switchable center pin accommodates both 6 roundwiring codes



9943

- 7 Blade to 4 Flat
- Easy-grip weatherproof design
- Includes dust cover



9942

- 7 Blade to 6 Round
- Includes dust cover
- Universal center pin accommodates both 6 Round wiring codes
- Corrosion resistant, tin-plated terminals



9945

- 6 Round to 4 Flat
- Includes dust cover



9948

- 6 Round to 7 Blade
- Die-cast zinc for durability (6 Round)
- Provides flexible reach

LIGHTS AND CONNECTORS

TRAILER CABLE

Trailer Cable

| Part Number | Gauge | Description |
|-------------|--------------|---------------------------------------------|
| 166100 | 16/6 | 100' spool, jacketed trailer cable |
| *166500 | 16/6 | 500' spool, jacketed trailer cable |
| *7500 | 12/3 14/4 | 500' spool, 7 strand jacketed trailer cable |

* Large spool also sold by foot

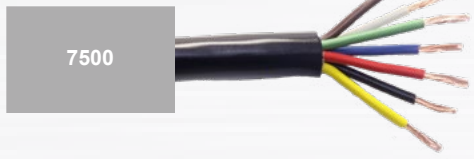

BONDED WIRE

Bonded Wire

| Part Number | Gauge | Description |
|-------------|-------|-----------------------------------|
| 183100 | 18/3 | 100' spool, bonded parallel wire |
| 183500 | 18/3 | 500' spool, bonded parallel wire |
| *1833000 | 18/3 | 3000' spool, bonded parallel wire |
| 184100 | 18/4 | 100' spool, bonded parallel wire |
| 184500 | 18/4 | 500' spool, bonded parallel wire |
| *1842000 | 18/4 | 2000' spool, bonded parallel wire |

* Large spool also sold by foot



JACKETED PRIMARY WIRE

Jacketed Primary Wire

| Part Number | Gauge | Description |
|-------------|-------|------------------------------------|
| 162BW100 | 16/2 | 100' spool, jacketed primary wire |
| *162BW500 | 16/2 | 500' spool, jacketed primary wire |
| *162BW2500 | 16/2 | 2500' spool, jacketed primary wire |

* Large spool also sold by foot



SINGLE STRAND WIRE

Single Strand Wire

| Part Number | Gauge | Description |
|-------------|-------|--------------------------------|
| 121100 | 12/1 | 100' spool, single strand wire |



CABLE LOOM

| Part Number | Length | Size | Description |
|-------------|--------|------|-----------------------------------------------------------------|
| *WL12 | 500' | 1/2" | Black polyethylene corrugated loom, split for easy installation |

* Large spool also sold by foot

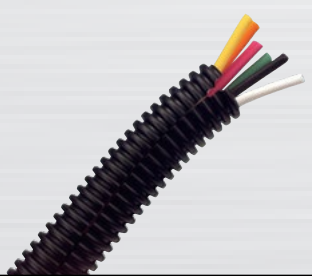



JUNCTION BOX

- ABS Plastic
- 7 Color Coded Terminals
- Wire Consolidation

PART Number: JB7



BUTT CONNECTORS

| Part Number | Gauge | Description |
|-------------|-------|---------------------------------|
| BC14-16 | 14-16 | Blue butt connector, bag of 100 |
| BC18-22 | 18-22 | Red butt connector, bag of 100 |

RING TERMINAL

| Part Number | Gauge | Stud/Tab Size | Description |
|-------------|-------|---------------|----------------------------------|
| RT10 | 16-14 | 10 | Bag of 25, heat shrinkable nylon |



12 VOLT BATTERY

- 5 amp hour rated
- Will hold 1 to 2 axle trailer brakes on for at least 15 minutes
- Rechargeable sealed battery

HOPKINS
TOWING SOLUTIONS

PART Number: 20008

BREAK AWAY SWITCH

HOPKINS
TOWING SOLUTIONS

- 7 inch wires
- 48 inch pin and cable
- Weatherproof design

PART Number: 2010

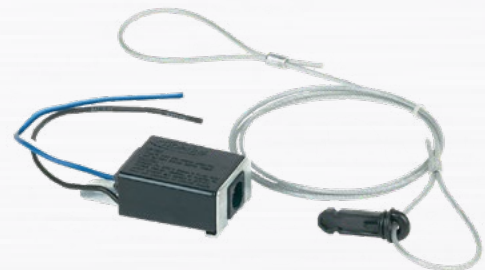

LED TEST BREAK AWAY KIT

HOPKINS
TOWING SOLUTIONS

- Brakes activate upon separation from tow vehicle
- 1 to 2 axle capacity
- Kit includes a break-away switch and cable and three mounting bolts
- For use with trailer equipped with up to 4 trailer brakes

PART Number: 20100



9AMP BREAKAWAY KIT

- Charger Included
- DOT Approved for E/H Actuators
- 110" & 120" Hoses
- Control valve, fittings, strap & cables

PART Number: 34-285

BRIGHTWAY BATTERY CHARGER

- 5 Amp Hours
- Fits Toolbox Cutout
- 12 Volt 5 Amp with Test Light



PART Number: TBCHARGER

Section J

Hardware and Accessories

| | |
|------------------------------------------|-----|
| Safety Chains | J-1 |
| Tie Downs | J-1 |
| Ratchet Straps & Winch Accessories | J-1 |
| Hinges | J-1 |
| Ramp & Tailgate Accessories | J-1 |
| Trailer Flooring Accessories | J-2 |
| Elbows & Pipe Caps | J-2 |
| Handles | J-2 |
| Trailer Winch | J-2 |
| Spare Tire Mount | J-2 |



HARDWARE & ACCESSORIES

J

SAFETY CHAINS

| Part No | Size | Description |
|---------|-------------|-----------------------------------------|
| 4004 | 3/16" x 48" | Safety chain with hooks and keeper |
| 4005 | 1/4" x 27" | Safety chain with hook and keeper |
| 4006 | 5/16" x 30" | Safety chain with hook; 18800# Capacity |
| 4007 | 3/8" x 35" | Safety chain, grade 70 with keeper |
| 177 | 7/16" | Safety clip for safety chain |
| 179 | 3/8" | Safety clip for safety chain |
| 180 | - | Weld On Clevis for 3/8" Chain |



4005



4007



179

TIE DOWNS

| Part No | Size | Description |
|---------|---------------|-----------------------------------------------------------------|
| 2414 | 3" x 4" | Straight stakepocket; 1/4" material |
| 58DR | 5/8" | Standard weld-on "D" ring; 6130# working load limit |
| 12DR | 1/2" | Standard weld-on "D" ring; 4080# working load limit |
| 1DR | 1" | Standard weld-on "D" ring, 15300# working load limit |
| 172 | 4.50" x 4.87" | Recessed rope ring / tie down ring; 6000# rated capacity |
| WF901 | 6.190" | Zinc plated, recessed ring, 360° rotation; 6000# rated capacity |



1DR



172



WF901

RATCHET STRAPS AND WINCH ACCESORIES

| Part No | Description |
|----------|-----------------------------------------------------------------------------------------------|
| 8110 | Standard weld-on winch for 3" x 4" |
| 8250 | Sliding winch, high profile, will hold approx. 30' webbing |
| 6112 | Weld-on slider winch track, 6' long |
| 6341 | Winch bar, painted black |
| 6361 | Winch bar, chrome combination |
| 6R27FH | 2" wide ratchet assembly with flat hook; 30' orange with PVC webbing 2000# working load limit |
| WS227FH | 2" wide winch strap with flat hook; 30' green with PVC webbing 3335# working load limit |
| WS427FH | 4" wide winch strap with flat hook; 30' green with PVC webbing 5400# working load limit |
| 43986-10 | 2" - 4" strap corner protector |
| WSW | Winch Strap Winder |



8110



6112



43986-10



8250



6361



6R27FH



WS247FH

HINGES

| Part No | Length | Pin | Description |
|---------|--------|------|---------------------------------------------|
| BH38 | 4" | 3/8" | Teardrop hinge with grease fitting |
| BH12 | 4.50" | 1/2" | Barrel hinge with grease fitting |
| BH17 | 7" | 1" | Barrel hinge with grease fitting; 1 1/4" OD |



BH38



BH12



BH17

RAMP AND TAILGATE ACCESSORIES

| Part No | Description |
|---------|--------------------------------------------------------------------|
| 175 | Pair of ramp springs; 1 - LH and 1 - RH; for 1 1/2" shaft |
| 176 | Pair of ramp springs for tailgate; 1 - LH and 1 - RH; for 1" shaft |
| 178 | Pair of ramp springs; 1 - LH and 1 - RH; for 2" shaft |
| 173 | 7/16" Linch Pin |
| 174 | Stabilizer Pin |



175



176



173



174

HARDWARE AND ACCESSORIES

HARDWARE & ACCESSORIES



| TRAILER FLOORING ACESORIES | | |
|----------------------------|----------------|------------------|
| Part No | Size | Description |
| 14214 | 1/4" x 2 1/4" | Torx floor screw |
| 516214 | 5/16" x 2 1/4" | Torx floor screw |
| T30 | - | Torx drive bit |
| T40 | - | Torx drive bit |
| 732DB | 7/32" | Drill bit |
| 932DB | 9/32" | Drill bit |



| ELBOWS AND PIPE CAPS | | |
|----------------------|--------|-------------|
| Part No | Size | Description |
| 15845 | 1 5/8" | 45° Elbow |
| 15890 | 1 5/8" | 90° Elbow |
| 158PC | 1 5/8" | Pipe Cap |
| 178PC | 1 7/8" | Pipe Cap |
| 238PC | 2 3/8" | Pipe Cap |
| 278PC | 2 7/8" | Pipe Cap |
| 312PC | 3 1/2" | Pipe Cap |
| 412PC | 4 1/2" | Pipe Cap |
| 658PC | 6 5/8" | Pipe Cap |



| HANDLES | |
|---------|------------------------------------------------|
| Part No | Description |
| 1ML | Key Lockable Paddle Handle; Electro-Galvanized |
| 1MLS | Key Lockable Paddle Handle; Stainless |
| 2ML | Folding T-Handle Latch; Zinc Plated |

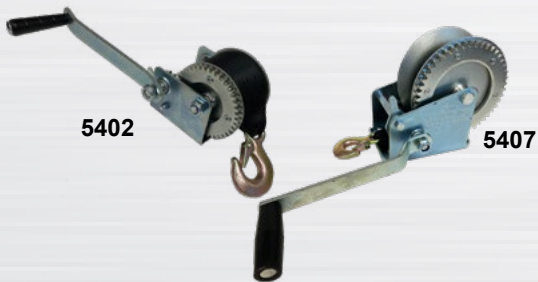

| TRAILER WINCH | |
|---------------|-------------------------------|
| Part No | Description |
| 5402 | Trailer winch; 600# capacity |
| 5407 | Trailer winch; 1600# capacity |

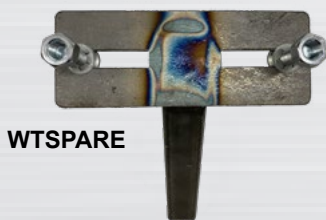

| SPARE TIRE MOUNT | |
|------------------|-----------------------------|
| Part No | Description |
| WTSPARE | 9" Weld-on spare tire mount |

HARDWARE AND ACCESSORIES

Section K

Towing and Accessories

Trailer Balls & Mounts K-1 & K-2
Receiver Tubes and Pins K-2



TRAILER BALLS AND BALL MOUNTS

TRAILER BALLS

| Part Number | Type | Diameter | Length | Rise | Capacity | Finish |
|-------------|---------|----------|--------|------|----------|--------|
| 94010 | 3" | 2" | 3 ¼" | 1" | 40K | Raw |
| 94004 | 2-5/16" | 1-1/4" | 2 5/8" | 0" | 30K | Raw |
| BHI | 2-5/16" | 1-3/8" | 3 ¼" | 1" | 30K | Zinc |
| 94006 | 2-5/16" | 1-1/4" | 2 ¾" | 1" | 30K | Raw |
| 98027 | 2-5/16" | 1" | 2 1/8" | 0" | 7.5K | Chrome |
| 98024 | 2" | 1" | 3" | 0" | 6K | Chrome |
| 98015 | 2" | 3/4" | 2 1/8" | 0" | 3.5K | Chrome |
| 98045 | 1-7/8" | 1" | 2 1/8" | 0" | 6K | Chrome |
| 98009 | 1-7/8" | 1" | 2 1/8" | 0" | 3.5K | Chrome |
| 98003 | 1-7/8" | 3/4" | 2 1/8" | 0" | 2K | Chrome |



BALL MOUNTS CLASS III

| Part No | GTW (lb) | TW (lb) | Drop | Rise | Length | Ball Hole | RCTS | Finish |
|---------|--------------------------|--------------------------|------|------|--------|-----------|------|-------------------------|
| O43 | 7.5K | 750 | 2" | ¾" | 7 ½" | 1" | 2" | Gloss Black Powder Coat |
| O45 | 7.5K | 750 | 4" | 2" | 8 ¼" | 1" | 2" | Gloss Black Powder Coat |
| O47 | Drop - 7.5K Rise - 6K | Drop - 750 Rise - 600 | 6" | 4" | 9 ¼" | 1" | 2" | Gloss Black Powder Coat |



FORGED BALL MOUNTS

| Part No | GTW (lb) | TW (lb) | Drop | Rise | Length | Ball Hole | RCTS | Finish |
|---------|----------|---------|------|------|--------|-----------|------|---------------------------|
| O50 | 15K | 1.5K | 2" | 1" | 8 ½" | 1 ¼" | 2" | Carbide Black Powder Coat |
| O52 | 7.5K | 2.55K | 4" | 3" | 8 ½" | 1 ¼" | 2" | Carbide Black Powder Coat |



ADJUSTABLE PINTLE MOUNTS

| Part No | GTW (lb) | Drop | Rise | Length | RCTS | Plate Ht | Face Plate | Finish |
|---------|----------|-------|------|--------|------|----------|--------------------|---------------------------|
| 041 | 10K | 6 ½" | ½" | 8 ½" | 2" | 7" | 1 ¾" H x 3 5/16" W | Carbide Black Powder Coat |
| 042 | 10K | 11 ½" | 6" | 12 ½" | 2" | 13" | 1 ¾" H x 3 5/16" W | Carbide Black Powder Coat |



PINTLE HOOKS

| Part No | GTW (lb) | Drawbar Eye Inner Diameter | M.V.L | Finish |
|------------|----------|----------------------------|-------|--------------------------------|
| PHT60AOL08 | 30K | 2.00-3.00 | 6K | Forged Steel Black Powder Coat |
| PH-400-1 | 100K | 2.38-3.00 | 20K | Cast Steel Black Powder Coat |



TOWING AND ACCESSORIES

TRAILER BALLS AND BALL MOUNTS



| MULTI-BALL MOUNT | | | | | | |
|------------------|---------------------|---------|----------|-------------|------|-------------------------|
| Part No | GTW/TW (lb) | TW (lb) | Diameter | Length | RCTS | Finish |
| 31004 | Ball 1 - 7.5K / 750 | 750 | 2" | 7" & 8 1/2" | 2" | Gloss Black Powder Coat |
| | Ball 2 - 10K / 1K | 1K | 2 5/16" | | | |



| FOLDING "HIDE-AWAY" HITCH BALL | | | |
|--------------------------------|----------|------------------------------------------|-------------|
| Part No | GTW (lb) | Description | Finish |
| 75065 | 25K | Requires 8" x 14 3/8" hole, 2 5/16" ball | Gloss Black |



| REDUCER BUSHING | | |
|-----------------|------------------------------------|-------------|
| Part No | Description | Finish |
| O58 | Reduces 1 1/4" diameter hole to 1" | Yellow Zinc |

TOWING AND ACCESSORIES

RECEIVER TUBES AND PINS

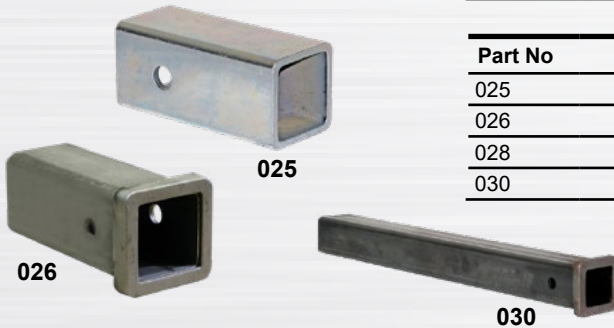

| RECEIVER TUBES AND ADAPTERS | | |
|-----------------------------|------------------------------------------------|--------------|
| Part No | Description | Material |
| 025 | 2.5" to 2" Receiver Tube Adapter, Zinc Plating | Carbon Steel |
| 026 | 2" Plain Receiver Tube, 6" Shank | Carbon Steel |
| 028 | 2" Plain Receiver Tube, 12" Shank | Carbon Steel |
| 030 | 2" Plain Receiver Tube, 24" Shank | Carbon Steel |



| HITCH PIN AND LOCK | |
|--------------------|-------------------------------------------------------------|
| Part No | Description |
| O20 | 5/8" diameter pin fits 2" x 2" receiver tubes |
| 694 | Receiver Lock, Bent Pin, 5/8" for 2" & 2-1/2" Sq. Receivers |

Section L

Dump Hoist and Accessories

| | |
|------------------------------|-----|
| Dump Hoist Kit | L-1 |
| Dump Hoist Accessories | L-1 |
| Tarp Kits | L-1 |



DUMP HOIST



DUMP HOIST KIT

| Part Number | Description |
|-------------|--------------------------------------------------------------------------------------------------------------------------------------------------------------------------------------------------------------------------------|
| H-520KIT | Dump Hoist Kit Contains: 5" x 20" Cylinder Powdercoated Hoist Assembly 4qt Power Unit 2.50" Locking Collars HD Hinges Prop Kit Load Control Valve Fittings Battery Strap & Cables 110" & 120" Hoses |
| H-620KIT | Dump Hoist Kit Contains: 6" x 20" Cylinder Powdercoated Hoist Assembly 4qt Power Unit 2.50" Locking Collars HD Hinges Prop Kit Load Control Valve Fittings Battery Strap & Cables 110" & 120" Hoses |

DUMP HOIST ACCESSORIES

| Part Number | Description |
|-------------|---------------------------------------------------------------------|
| H-PU4 | 4qt Dual Acting Hydraulic Power Unit with Remote Pendant |
| H-REMOTE | Hydraulic Remote Pendant |
| H-CAP | Hydraulic Power Unit Cap |
| H-SR391 | Starter Relay 12V DC 250A |
| H-SL13392Q | Square Solenoid for Port A |
| H-SL13372R | Round Solenoid for Port B |
| H-C520 | 5" x 20" Hydraulic Cylinder |
| H-F38 | 3/8" Hydraulic Fitting |
| H-F3890 | 3/8" Hydraulic Fitting, 90° |
| H-H110 | 3/8" x 110" Hydraulic Hose |
| H-H120 | 3/8" x 120" Hydraulic Hose |
| H-HDH | Heavy Duty Hinge for Dump Trailer |
| H-LC25 | 2.5" Hydraulic Locking Collar |
| H-VALVE | Hydraulic Load Control Valve |
| H-TB310 | Tilt Bed Cylinder Assembly; 3" x 10"; Pins and Cotter Keys Included |
| H-TB-CS1 | Weld On Bracket for Tilt Cylinder |
| H-TB-CS2 | Weld On Rear Bracket for Tilt Cylinder |
| H-BC | Pair of Battery Cables; 4GA x 20" |

TARP KITS

| Part Number | Description |
|-------------|--------------------------------------------------------------------------------------------------------|
| TK8314 | 83" x 14' Trailer Length; 18' Tarp Length; Front Hex Tube; Rear Anti Slip Rod; Handle and Hardware Kit |
| TK8318 | 83" x 18' Trailer Length; 22' Tarp Length; Front Hex Tube; Rear Anti Slip Rod; Handle and Hardware Kit |
| TK18 | 83" x 18' Tarp |
| TK22 | 83" x 22' Tarp |



DUMP HOIST AND ACCESSORIES



H-C520



H-LC25



H-BC



H-H110
H-H120



H-VALVE



HINGES



H-HDH



H-F3890



H-TB310



H-PU4



PROP KIT



H-F38



H-REMOTE



TK18
TK22



TK8314
TK8318

DUMP HOIST AND ACCESSORIES